

Spring clamping cylinder I Series ZDF-u

- /// mechanical clamping – hydraulic releasing
- /// high operation safety, /// leakproof and robust
- /// temperature range: -30°C up to +100°C /// mounting position discretionary

Technical data:

ZDF-u Size	nominal clamping force [kN]	adjusting pressure [bar]	max. release stroke [mm]	release pressure at 0,5 mm stroke [bar]	release pressure at 1,0 mm stroke [bar]	release pressure at max. stroke [bar]	stroke volume at 1 mm stroke [cm ³]	mass approx. [kg]
2.500	25	160	1,2	205	250	270	2,0	3,8
4.000	40	200	1,5	240	280	320	2,3	5,7
6.300	63	180	1,0	205	230	-	4	7,8
10.000	100	210	1,0	240	270	-	6	14
16.000	160	205	1,5	250	290	330	9	25
25.000	250	200	1,5	230	260	300	13	34

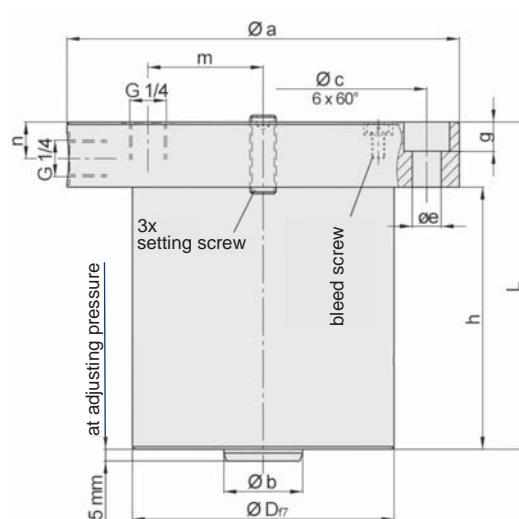
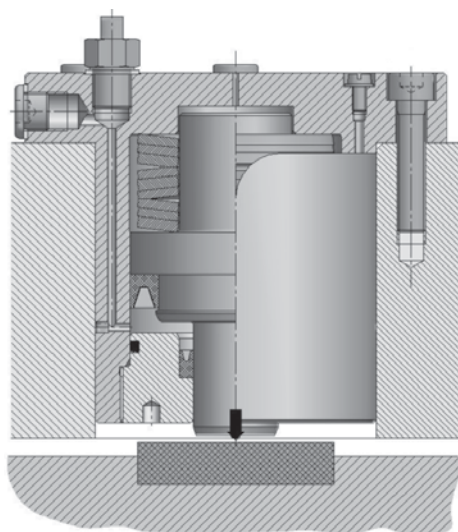

Material: heat. treated steel black finished or rather nitrocarburized

Dimensions: (mm) length dimensions according to DIN ISO

ZDF-u	Ø D	Ø a	Ø b	Ø c	Ø e	g	h	L	m	n
2.500	75	105	20	90	6,5	7	85	110	30	14
4.000	90	138	30	115	11	10	90	115	37	14
6.300	100	150	30	125	11	10	100	125	44	14
10.000	120	170	30	145	12,5	12	125	150	51	14
16.000	150	210	40	185	12,5	12	140	170	65	15
25.000	180	230	50	205	12,5	12	150	180	80	15

Ordering example: ZDF-u 6.300