



V-60~63

HYDRAULIC MACHINE VICE

Model: HH-100, 125, 150, 200

- Constructed with HYDRAULIC CYLINDER, which absorbs cutting vibration and improves the precision of machining whilst maintaining a high clamping force.
- The clamping force can be adjusted accurately by use of a DIAL.
- Vice Body is made of high tensile cast iron. The Sideways are hardened and ground to ensure rigidity, durability and minimal deformation.
- The vice Jaws are made of a special hardened ALLOY STEEL and are precision ground.

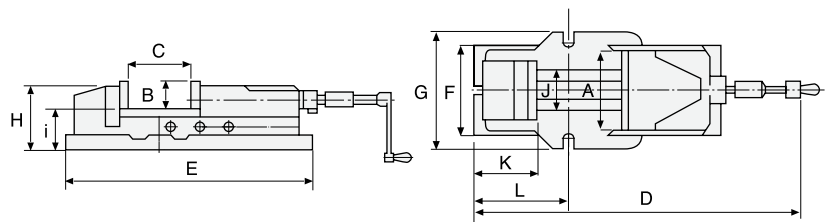

Unit: mm

SPECIFICATIONS

NO	Model	A	B	C	D	E	F	G	H	I	J	K	L	Clamping Force	Weight(kg) Body	Weight (kg) Swivel Base
V-60	HH-100	100	36	170	525	430	130	160	94	58	78	100	155	2500	16	6
V-61	HH-125	125	46	220	670	540	165	185	118	70	97	117	185	3500	33	7
V-62	HH-150	150	51	300	800	620	200	240	133	82	116	125	207	4500	54	16
V-63	HH-200	200	62	300	900	700	225	280	160	100	160	150	265	8000	90	20



V-64~65

TILTING HYDRAULIC MACHINE VICE

Model: HW-100, 150

- Constructed with the same specifications as the HH-Type above.
- Having the added tilting function it is particularly well suited to many jig and fixture making applications as well as being more versatile for general machining work.

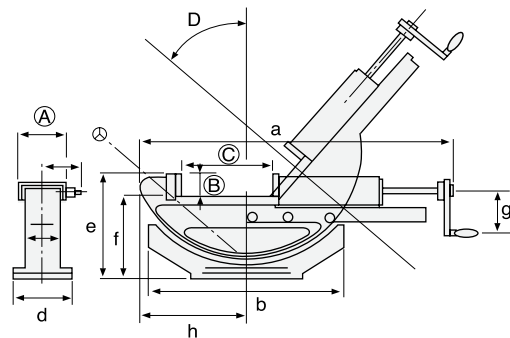

Unit: mm

SPECIFICATIONS

NO	Model	A	B	C	D	a	b	c	d	e	f	g	h	Weight (kg) Body	Weight (kg) Swivel Base
V-64	HW-100	100	36	170	50°	505	325	65	160	191	155	80	170	23	4
V-65	HW-150	150	51	300	50°	775	410	95	240	250	197	100	200	60	10