

Safety Coupling I Series SKY-ES for direct drives

// with elastomer attachment for direct drives // with conical clamping hub
 // plug-in // backlash-free // flexible // robust // oscillation dampening

technical data:

SKY -ES size	setting range		moment of inertia [10 ⁻³ kgm ²]	mass approx. [kg]	torsional stiffness [Nm/arcmin]	max. shaft alignment [mm]		tightening torque of screws		Ø D1		Ø D2	
	disengagement torque	T _{KA} [Nm]				axial ±	lateral	„f“ [Nm]	„i“ [Nm]	min	max	min	max
6	2	- 6	0,13	0,5	0,25	0,5	0,1	6xM4[4]	M3[1.5]	9	19	5	11,5
12	6	- 12								9	19	5	11,5
15	8	- 15	0,5	1,0	1,0	0,5	0,1	4xM5[8]	M4[3]	12	26	9	17
30	13	- 30								12	26	9	17
45	22	- 45	1,4	1,9	1,2	1	0,1	8xM5[8]	M6[12]	12	26	10	17
60	25	- 60								12	36	12	24
100	40	- 100	5,5	4,3	3,6	1	0,12	4xM8[35]	M6[12]	12	36	12	24
150	60	- 150								14	36	14	24
230	80	- 230	18,5	8,8	8	1	0,15	4xM12[115]	M8[30]	19	40	18	35
330	130	- 330								19	40	22	35
500	200	- 500	57	16	12	1	0,1	4xM12[115]	M12[90]	25	60	28	42
800	350	- 800								28	60	30	42
1000	500	- 1000	102	25,6	21	1	0,15	8xM12[115]	M12[90]	35	60	40	65
2000	800	- 2000								35	85	40	65

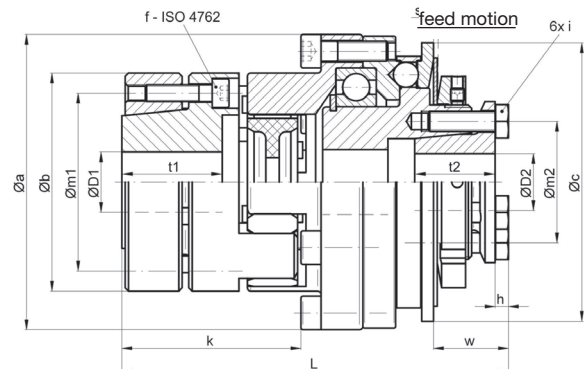
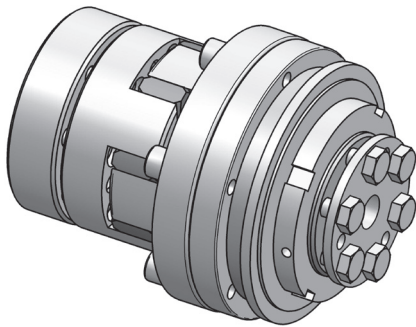

material: safety part: heat-treated steel
 hub: high-tensile aluminum
 (size 2000: tempered steel)
 clamping ring: heat treated steel

elastomer spider: polyurethane – 98 Shore A
 screws: ISO 4762 / 12.9
 temperature range: -30°C up to +90°C

Dimensions [mm]: length dimensions according to DIN ISO 2768 cH

SKY-ES	Øa	Øb	Øc	h	k	L±1	Øm1	Øm2	s	t1	t2	w
6/12	52,5	40	48	3	41	83	31	19	0,9	21	15	14
15/30/45	69	55	66	4	48	100	43	27	1,2	25	18	18
60/100/150	88	65	83	4	53,5	115,5	53	36	1,6	30	24	22
230/330	115	80	109	4	68	145,5	64	50	1,8	40	27	24
500/800	137	120	132	5,3	94	187	96	62	2,5	54	32	33
1000	181	120	185	7,5	95	218	96	98	3,7	54	45	64,5
2000	181	160	185	7,5	114	236,5	130	98	3,7	66	45	64,5

Note: elastomer spider optionally available with alternative shore hardness
 coupling side with radial clamping hub, see series SKY-EK

order example: SKY-ES 230 - D1 = 33^{H7} - D2 = 28^{H7} - T_{KA} = 200 Nm