

Safety Coupling I Series SKB-KP *for direct drives*

- /// with bellows attachment // with lateral clamping hub on both sides
- /// EASY-clamping hub on bellows side // compensation of misalignments // low restoring forces

technical data:

SKB-KP size	setting range disengagement torque T_{KA} [Nm]	moment of inertia $[10^{-3} \text{kgm}^2]$	mass approx. [kg]	torsional stiffness [Nm/arcmin]	max. shaft misalignment [mm]		tightening torque of screws		$\varnothing D1$		$\varnothing D2$	
					axial \pm	lateral	f [Nm]	i [Nm]	min	max	min	max
1	0,5 - 1											
2	1 - 2	0,05	0,26	0,4	0,5	0,1	M3-2	M5-10	5	10(14)	5	14
6	2 - 6											
12	6 - 12	0,13	0,45	2,1	0,5	0,15	M5-8	M5-10	6	19(24)	6	16
15	8 - 15								8	32	10	25,4
30	13 - 30	0,5	1,0	9	0,5	0,2	M6-14	M6-18	10	32	12	25,4
45	22 - 45								12	32	14	25,4
60	25 - 60								13	30(38)	18	35
100	40 - 100	1,5	1,9	20	0,6	0,2	*M8-35 (30)	M8-40	14	30(38)	18	35
150	60 - 150								21	30(38)	24	35
230	80 - 230	5,5	3,8	28	0,8	0,2	*M10-65 (50)	M10-80	24	32(43)	24	44
330	130 - 330								32	32(43)	32	44
500	200 - 500	14,0	6,8	52	0,8	0,2	*M12-115 (90)	M14-220	35	42(55)	28	58
800	350 - 800	17,2	8,3	106	0,7	0,2	*M14-180 (140)	M14-220	42	55(68)	40	58
1000	500 - 1000	80	20	150	0,8	0,2	*M14-180 (140)	2xM16-290	45	65(75)	42	100
2000	800 - 2000	95	21	210	1	0,3	*M16-300	2xM16-290	58	90	45	100

(*) note: reduced tightening torque for bigger hub bore diameter - see also $\varnothing D1/D2$ max!



update version

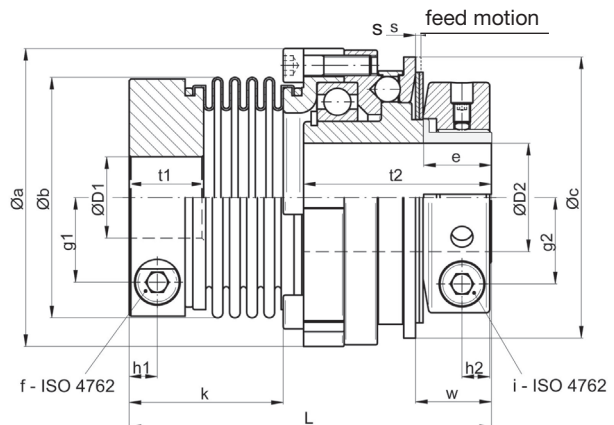
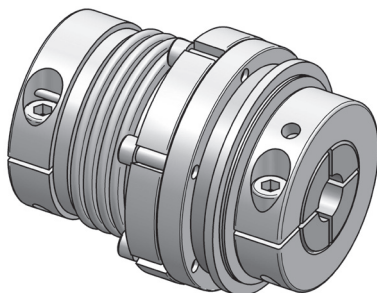

material:

safety part: heat-treated steel

clamping hub: high-tensile aluminum

bellows: stainless steel

screws: ISO 4762 / 12.9

temperature range: -30°C up to +200°C

Dimensions [mm]: length dimensions according to DIN ISO 2768 cH

SKB-KP	$\varnothing a$	$\varnothing b$	$\varnothing c$	e	g1	g2	h1	h2	k	$L_{\pm 1}$	s	t1	t2	w
1/2	40,5	24(28)	42	14	7,5	13,5	4,4	6	25	62,5	0,8	8	33	14,6
6/12	52,5	40 (45)	48	14	13	13,5	6	6	36,6	81	0,9	16,5	41	16
15/30/45	69	56	66	16	19	19,5	8	7,5	43	94,5	1,2	20	48	18,5
60/100/150	88	71	83	20	25	25,5	9	8,5	45,5	107	1,6	22	55,5	22
230/330	115	82	109	23	28,5	32	11,5	10,5	52	132	1,8	26	72	26
500	137	101	132	32	35	42	13	13,5	60	156	2,5	29	87,5	37
800	137	122	132	32	42	42	16	13,5	74,5	170	2,5	34	87,5	37
1000	181	133	185	74	47	69	18,5	17/30	87,5	220 \pm 2	3,7	45	124	74
2000	181	157	185	74	54	69	17,5	17/30	99	232	3,7	35	124	74

*note: alternative lengths of bellows are possible on request; bellows side with conical hub: see series SKB-KS
setting range up to 9000Nm see series SKY-KS

order example: SKB-KP 30 - $D1 = 28^{G6}$ - $D1 = 24^{H7}$ - $T_{KA} = 25 \text{ Nm}$