

# Metal Bellows Coupling I Series KSS

/// straight bellows /// conical bush on both sides /// low restoring forces /// high torsional stiffness

technical data:

KSS Size	T <sub>N</sub> [Nm]	moment of inertia [10 <sup>-3</sup> kgm <sup>2</sup> ]	torsional stiffness [Nm/arcmin]	max. shaft misalignment (mm)		axial spring rate [N/mm]	lateral spring rate [N/mm]	mass approx. [kg]	tightening torque screws „f“ [Nm]
				axial ±	lateral				
25	25	0,1	10	0,3	0,2	150	150	0,4	3
50	50	0,1	11	0,3	0,2	160	170	0,4	3
65	65	0,3	13	0,3	0,3	90	80	0,7	10
100	100	0,75	24	0,5	0,4	100	95	1,2	10
200	200	0,84	30	0,3	0,3	220	120	1,25	10
300	300	2,3	53	0,4	0,3	210	160	2,2	25
450	450	2,4	80	0,4	0,3	300	260	2,3	25
540	540	4,8	100	0,5	0,5	300	360	3,4	50
850	850	18	160	0,7	0,6	200	170	7,5	90
1500	1500	19	290	0,6	0,5	520	490	7,7	90
2500	2500	100	700	0,4	0,5	550	590	23	210

temperature range: -40°C up to +300°C  
for higher torques see series KXL

material:

bellows: stainless steel  
hubs: heat treated steel  
screws: ISO 4017 / 10.9

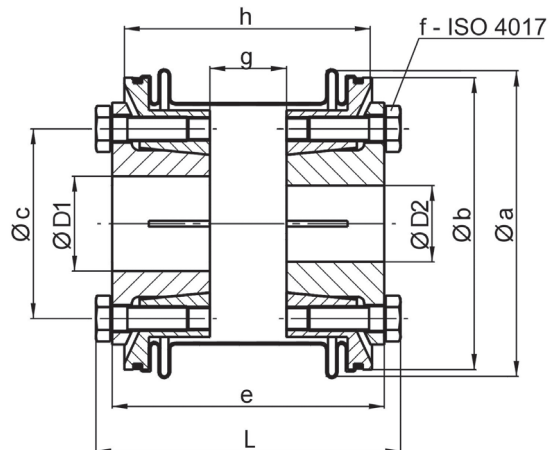
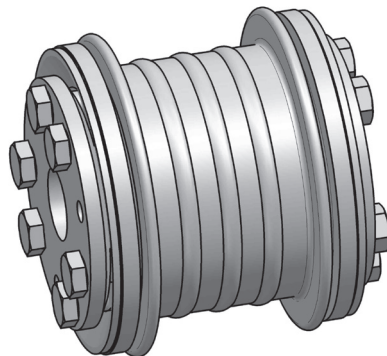

Dimensions [mm]: length dimensions according to DIN ISO 2768 cH

KSS	Ø a	Ø b	Ø c	e	6 x f	g	h	L	Ø D 1/2		prebored
									min.	max.	
25	56	52	30	51	M 4	15	47	57	10	19	8
50	56	52	30	51	M 4	15	47	57	12	19	8
65	66	62	36	61	M 6	13	55	69	12	24	11
100	82	78	50	70	M 6	16	64	78	18	35	17
200	82	78	50	76	M 6	22	70	84	22	35	17
300	101	96	62	89	M 8	25	81	101	28	42	25
450	101	96	62	89	M 8	25	81	101	28	42	25
540	122	112	70	98	M 10	26	88	111	35	48	28
850	157	140	98	137	M 12	44	119	152	40	70	38
1500	157	140	98	137	M 12	44	119	152	42	70	38
2500	203	194	138	211	M 16	72	161	231	50	102	49

order example: KSS 450 - D1 = 28<sup>H7</sup> D2 = 35<sup>F6</sup>