

Metal Bellows Coupling I Series KPS

- /// 4-corrugation bellows // short design // simple installation with radial EASY-clamping hub
- /// expanding cone hub for direct mounting // internal axial stop

technical data:

KPS size	T_N [Nm]	moment of inertia [10^{-9}kgm^2]	torsional stiffness [Nm/arcmin]	max. shaft misalignment (mm)		axial spring rate [N/mm]	lateral spring rate [N/mm]	mass approx. [kg]	tightening torque of screws f / i [Nm]
2	2	0,01	0,4	0,25	0,1	32	100	0,03	2 / 2
8	8	0,02	1,9	0,5	0,15	20	90	0,1	8 / 8
20	20	0,13	7	0,5	0,2	70	480	0,3	14 / 14
60	60	0,28	13	0,6	0,2	70	650	0,4	35 (30) / 35
170	170	0,94	27	0,8	0,2	100	1000	0,8	65 (50) / 65
400	400	1,95	64	0,7	0,2	135	1500	1,4	115 (90) / 115
600	600	4,2	107	0,7	0,2	145	3000	2,7	180 (140) / 115

(*) note: reduced tightening torque for bigger hub bore diameter - see also $\text{Ø} D 1_{\text{max}}$!

material:

bellows: stainless steel

hubs: high-tensile aluminum

expanding cone: heat-treated steel

screws: ISO 4762 / 12.9

temperature range:

-40°C up to +200°C



update version

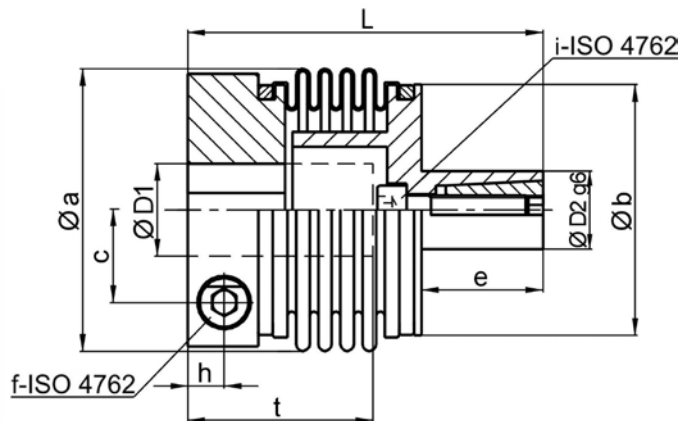
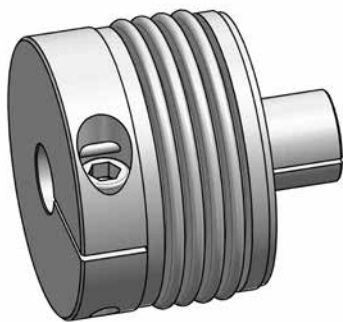

Dimensions [mm]: length dimensions according to DIN ISO 2768 cH

KPS	Øa	Øb	c	e	f / i	h	L	t_{min}	t_{max}	ØD1		ØD2	
										min	max	min	max
2	24,5 [27,5]	22	7,5	10	M 3	4,5	38	11	20 [14]	3	10 [14]	8	12
8	40 [44,5]	35	13	20	M 5	6	61	15,5	33	6	19 [21]	13	18
20	56	51	19	23	M 6	8	71	19	38	8	32	15	20
60	66	61	22	23	M 8	9	75	21	40	13	28 [35]	20	28
170	82	77	28,5	30	M 10	11,5	92	25	48	18	32 [43]	24	32
400	101	95	35	32	M 12	13	102	28	56	28	42 [55]	30	38
600	122	110	42	42	M14/M12	16	120	31	63	32	55 [68]	35	48

note: the bore sizes for the expanding cone $> \text{Ø} D2_{\text{g}6} <$ with tolerance H7 sizes KPS 2 and KPS 8 without EASY-clamp, available in two diameters (see squared brackets).

application example: compact and integrated attachment of a KPS

order example: KPS 20 - D1 = 15^{H7} - D2 = 20 g6

