

TECNIMETAL

-  **Protezioni a soffietto**
-  **Bellows**
-  **Balgenabdeckungen**
-  **Soufflets de protection**





PROFILO TECNIMETAL

 TECNIMETAL, con sede in S. Giovanni in Croce - Cremona, operante nella costruzione di articoli tecnici per macchine utensili dal 1974, è costantemente impegnata nella ricerca e nelle innovazioni produttive, unitamente ad una tradizione di qualità ed affidabilità, che ha determinato un progressivo sviluppo dell'azienda ed una sua affermazione nel mercato nazionale ed internazionale.

Esperienza, specializzazione e conoscenza delle problematiche dei clienti, sono il fondamento dell'ufficio tecnico.

I più avanzati strumenti di calcolo e progettazione, danno luogo a nuovi layout di prodotti, che offrono soluzioni tecniche mirate alle diverse esigenze.

I nostri tecnici sono al servizio del cliente dalla fase iniziale dello studio di un progetto fino alla fase della messa in servizio.

Lavorando prevalentemente su commessa, l'azienda ha sviluppato una flessibilità tale che le permette di costruire nella sua gamma di prodotti, qualsiasi tipo di attrezzatura speciale, nel settore della macchina utensile.

All'interno dello stabilimento si sviluppa l'intero ciclo produttivo che parte dalle materie prime ed arriva al prodotto finito.

La produzione "TECNIMETAL" comprende i seguenti articoli:

- Protezioni a soffietto;
- Protezioni a nastro;
- Carenature;
- Convogliatori di trucioli;
- Protezione telescopiche in lamiera d'acciaio speciale;
- Catene portacavi;
- Protezioni telescopiche a spirale;
- Raschiaolio in barre e sagomati;
- Protezioni a tapparella.

L'accurata selezione dei materiali titolati, la professionalità del personale, le avanzate tecniche produttive e la serietà commerciale sono le ragioni del successo TECNIMETAL.

Un successo che trova riscontro nelle numerose macchine ed impianti operanti in Italia e in tutto il mondo.

TECNIMETAL, la scelta dell'affidabilità.

TECNIMETAL PROFILE

 TECNIMETAL, headquartered in S. Giovanni in Croce - Cremona, has been a top manufacturer of machine tool accessories since 1974, and is constantly engaged in research and product innovation, together with a tradition of quality and reliability, which has propelled TECNIMETAL's progressive expansion into the national and international markets.

Experience, specialization, and a clear understanding of costumers concerns are the basis of the technical department.

Advanced calculation and design instruments give rise to new products, which offer technical solutions for a vast number of requirements.

Our Technicians keep client concerns and needs in mind from the beginning of a design study to the actual installation of the equipment.

Working primarily on custom-made products, our company is among the most versatile in the world, allowing us to design and manufacture nearly any kind of special equipment in the machine tools field.

TECNIMETAL's range includes the following products:

- Bellow covers;
- Roll up covers;
- Machine fairings;
- Chip conveyors;
- Steel telescopic way covers;
- Cable carriers;
- Helical metal spring guards;
- Way wipers;
- Apron covers.

The accurate selection of high quality materials, the close attention to detail, and the flexibility of our customer solutions, compounded by our professional and courteous staff and commercial dedication, make TECNIMETAL a leader of the industry. Our expertise in equipment design, manufacture and implementation can be found in installations throughout Italy and the rest of the world.

TECNIMETAL is the choice of reliability.

 **INDICE**

 **INHALTSVERZEICHNIS**

 **INDEX**

 **INDEX**

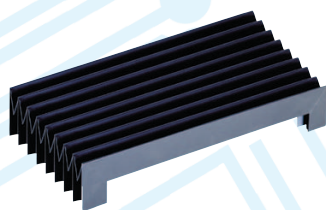

Soffietti termosaldati

10-13

*Welded bellows
Thermogeschweisste Bälge
Soufflets thermo-soudés*

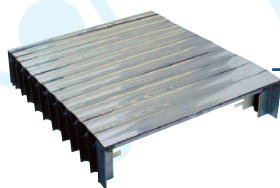

Soffietti con lamelle

14-17

*Finned bellows
Bälge mit lamellen
Soufflets avec écailles métalliques*

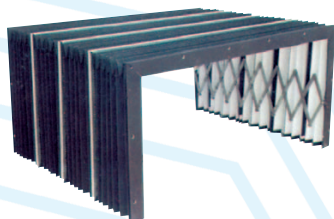

Soffietti standard

18-21

*Standard bellows
Standardbälge
Soufflets standard*

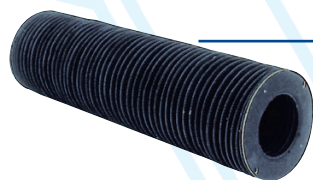

Soffietti tubolari termosaldati o cuciti

22-25

*Tubular sewn or welded bellows
Faltenbälge genäht oder thermogeschweisst
Soufflets tubulaires cousus ou soudés*



Soffietti rotondi in gomma

26-27

*Round rubber bellows
Runde Gummifaltenbälge
Soufflets ronds en caoutchouc*



Soffietti piani con lamelle telescopiche

28-29

*Plain bellows with telescopic sheets
Faltenbalgjalousie mit Teleskopblechen
Soufflets plats avec écailles télescopiques*

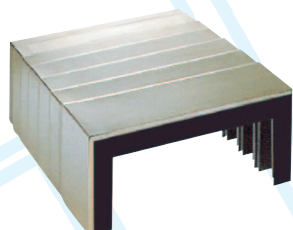

Soffietti con protezione telescopica su tre lati

30-31

*Bellows with telescopic sheets on three sides
Faltenbalg mit Teleskopblechen auf 3 Seiten
Soufflets avec protecteur télescopique sur trois côtés*

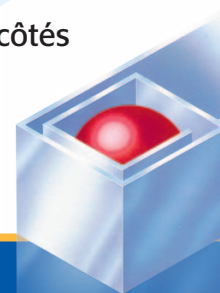

PROTEZIONI A SOFFIETTO

È il tipo di protezione più versatile. Può essere applicata a qualunque macchina utensile, grazie alle sue forme più disparate e agli spazi esigui che occupa.

BELLOWS

These are the most versatile type of way cover. They can be applied to any machine tools, thanks to their most diverse shapes and the small space they take.

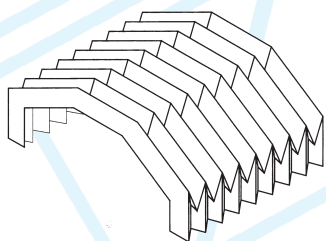

T1

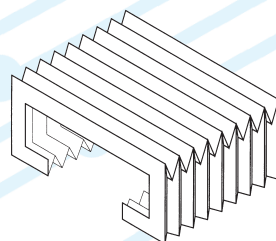

T2

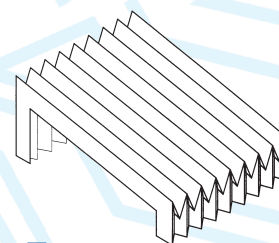

T3

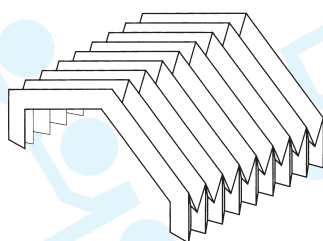

T4

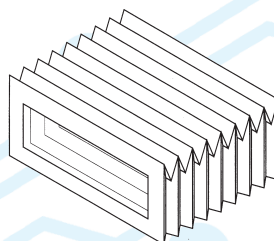

T5

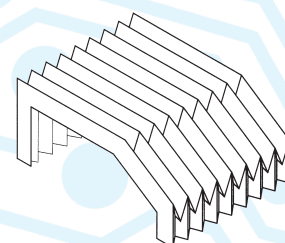

T6

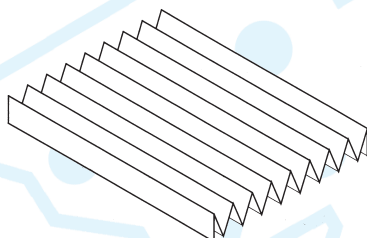



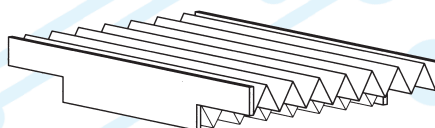

T7

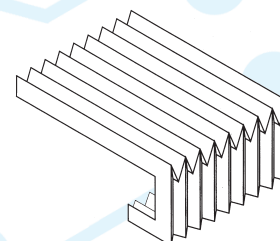

T8



T9

-  **Principali forme realizzabili**
-  **Main Feasible shapes**
-  **Hauptformen**
-  **Principales formes réalisables**

BALGENABDECKUNGEN

Das ist die vielseitigste Abdeckung. Aufgrund ihrer vielfältigen Formen und geringem Raumbedarfes sind sie für jede Werkzeugmaschine geeignet.

SOUFFLETS DE PROTECTION

C'est le type le plus versatile de protecteur le plus couramment utilisé. Il s'applique sur n'importe quelle machine, grâce à la grande diversité de formes et à leur faible encombrement.

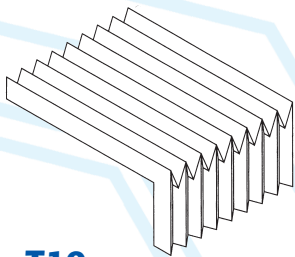

T10

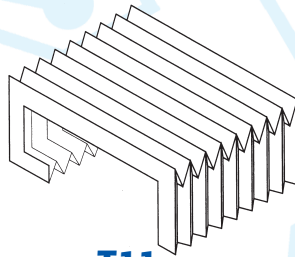

T11

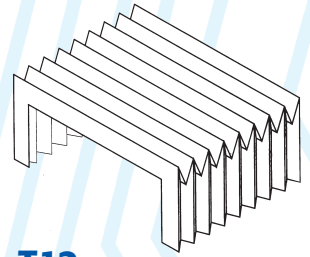



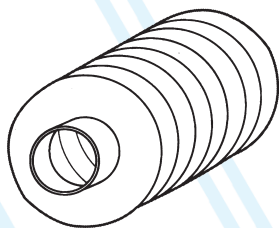

T12

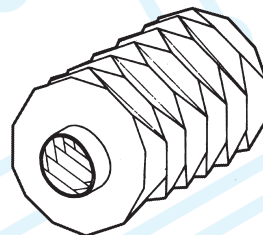

T13



T14

-  **Principali forme realizzabili**
-  **Main Feasible shapes**
-  **Hauptformen**
-  **Principales formes réalisables**

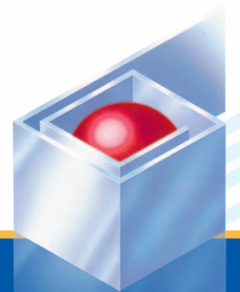

 **SOFFIETTI ORIZZONTALI**

 **HORIZONTAL BELLOWS**

 **HORIZONTALBÄLGE**

 **SOUFFLETS HORIZONTALAUX**

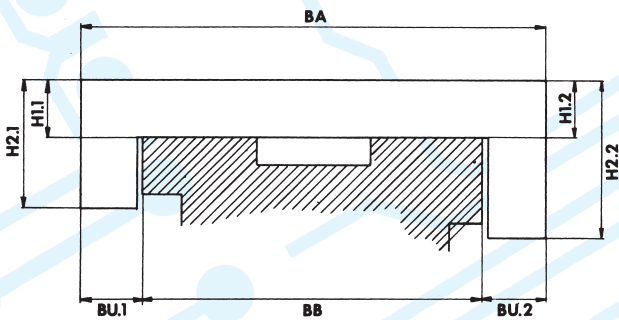
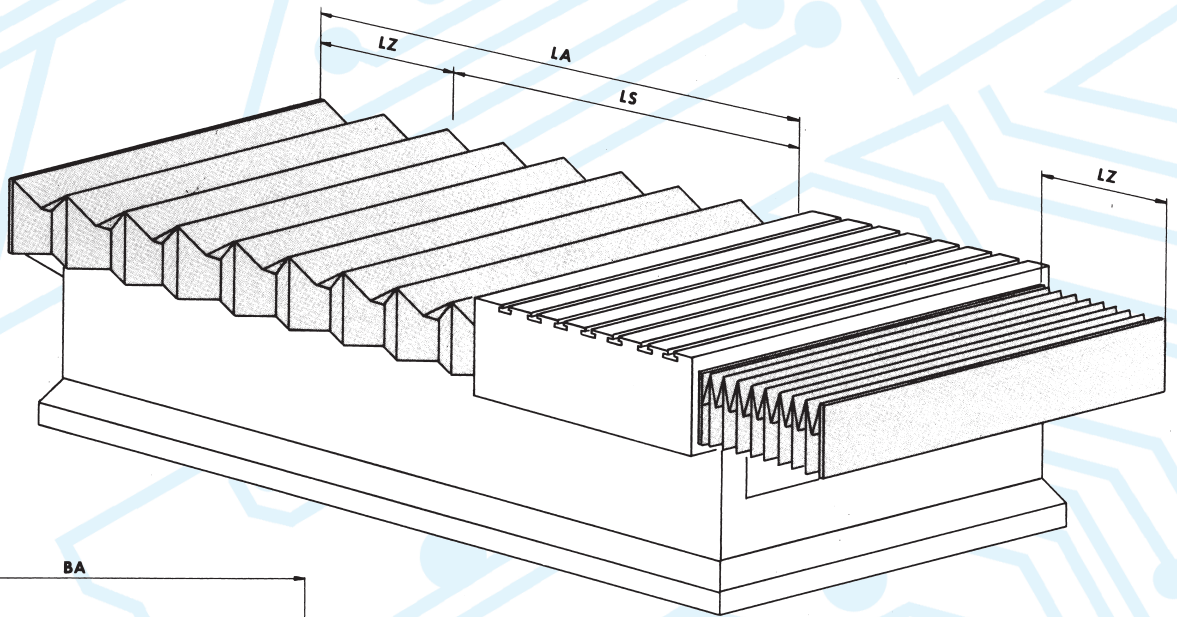

 **SOFFIETTI TRASVERSALI**

 **CROSS-RAIL BELLOWS**

 **QUERBÄLGE**

 **SOUFFLETS TRANSVERSAUX**

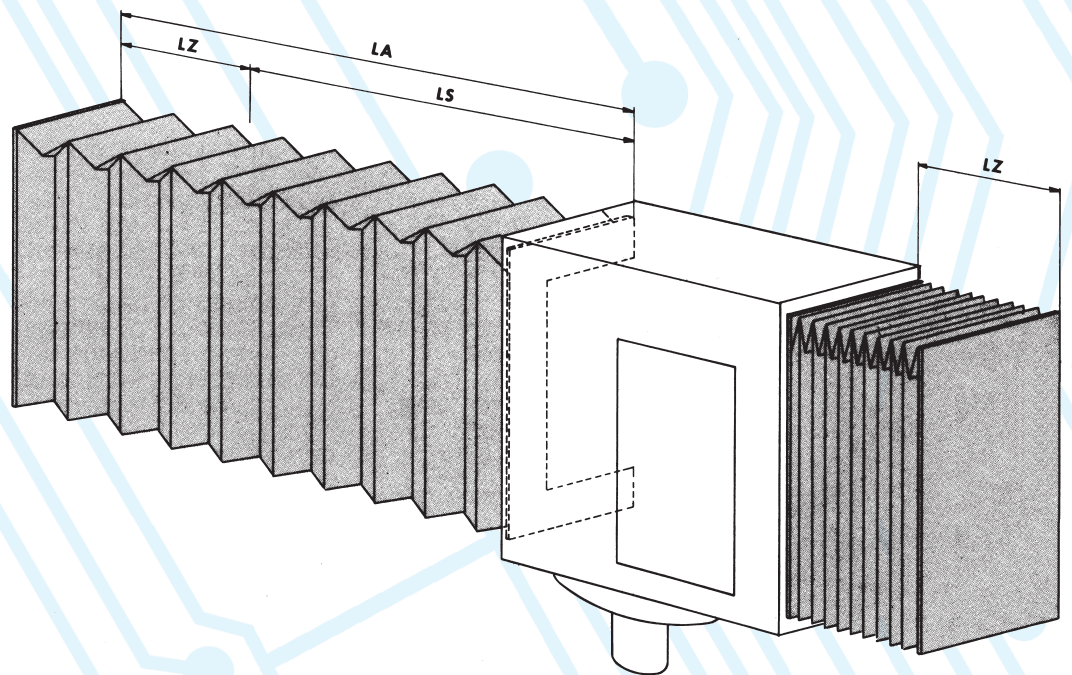
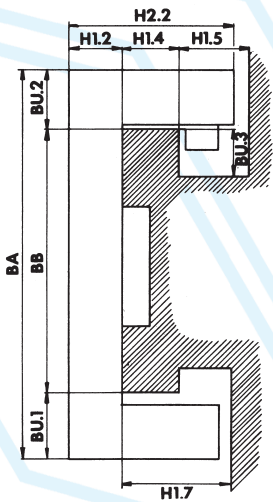

 **SOFFIETTI VERTICALI**

 **VERTICAL BELLOWS**

 **VERTIKALBÄLGE**

 **SOUFFLETS VERTICAUX**

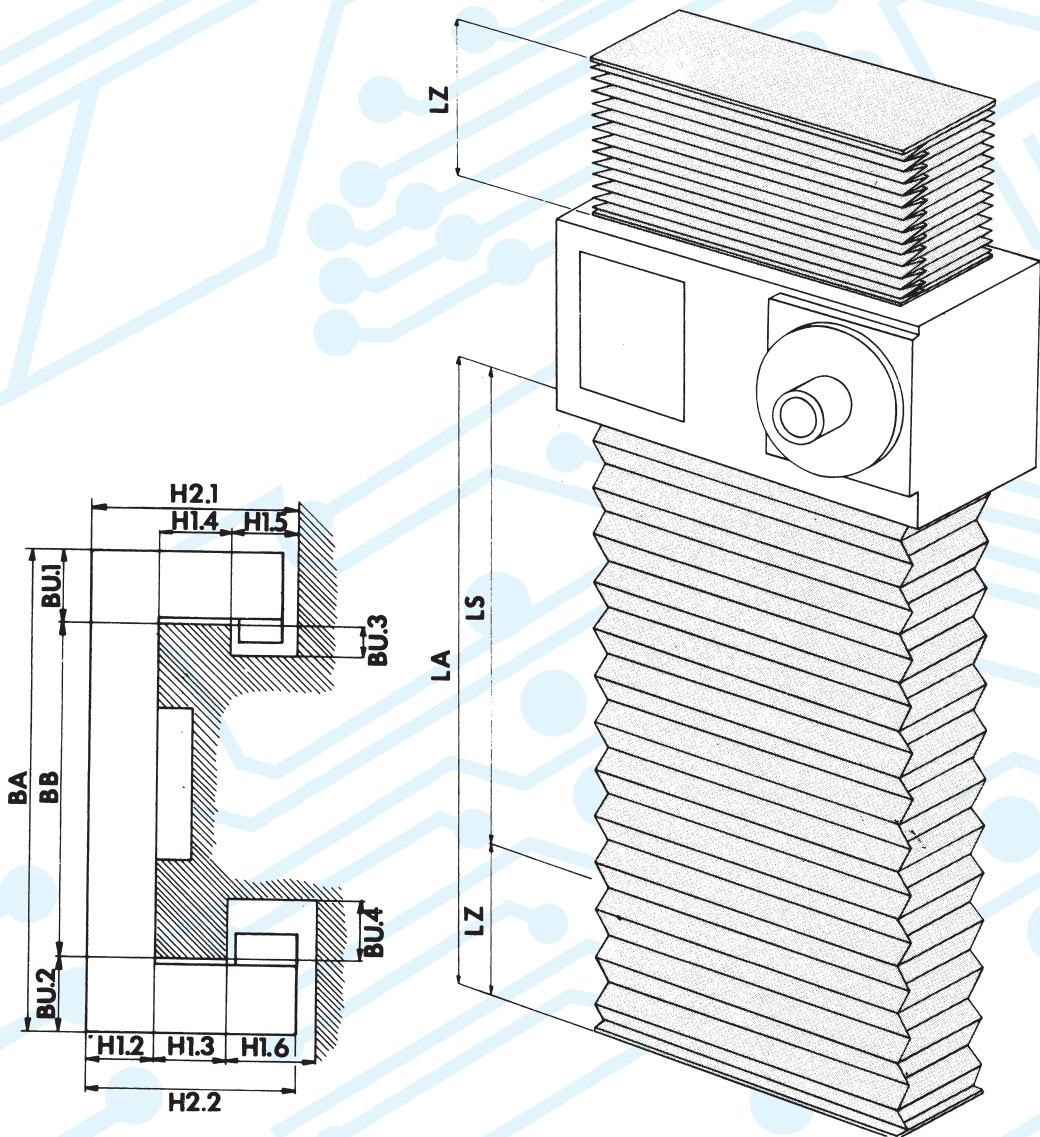

 **SOFFIETTI TUBOLARI**

 **TUBULAR BELLOWS**

 **ROHRBÄLGE**

 **SOUFFLETS TUBULAIRES**

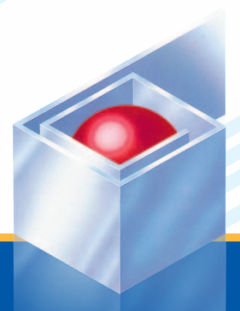
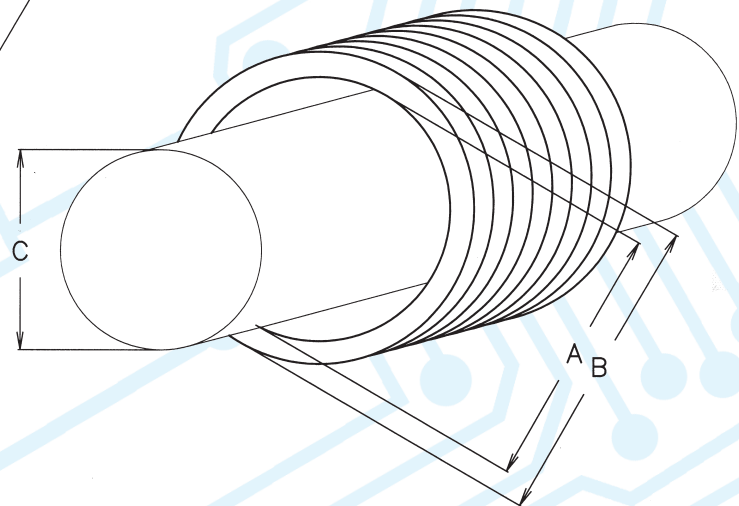
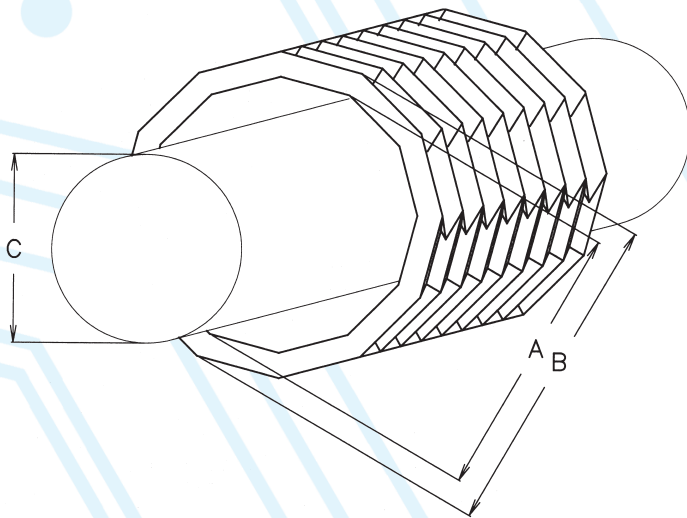

SOFFIETTI TERMOSALDATI

È la versione più evoluta del soffiETTO, che risolve tutti i problemi tipici di questa protezione.

THERMAL WELDED BELLOWS

It is the most advanced version of bellow, which resolves all the typical problems of this type of way cover.

THERMOGESCHWEISSTE BÄLGE

Eine ganz besondere Ausführung, die sämtlichen Anforderungen dieser Schutzabdeckung entspricht

SOUFFLETS THERMO-SOUDES

C'est la version la plus évoluée du soufflet, qui résout tous les problèmes spécifiques de ce type de protecteur.

CARATTERISTICHE

- Resiste ai liquidi refrigeranti non avendo particolari incollati.
- È indeformabile.
- Presenta ingombri a pacco chiuso assai ridotti.
- Può raggiungere velocità di ben 200 mt./min.
- Non monta all'interno alcun particolare metallico che cadendo sopra una guida può creare seri problemi alla macchina.

MERKMALE

- Kühlmittelbeständig, da keine besonderen Kleber verwendet werden.
- Unverformbar.
- Geringe Abmessungen im zusammengeschobenem Zustand.
- Erreicht Geschwindigkeiten bis zu 200 mt./min.
- Keine metallischen Innenteile, die Maschine beschädigen könnten.

FEATURES

- Coolant resistant without glued parts.
- It has a crush-proof structure.
- It has a very reduced compressed size.
- It can reach speeds up to 200 mt./min.
- It has no metal parts inside which may cause serious damage to machines while falling onto slideways.

CARACTÉRISTIQUES

- Il résiste aux liquides réfrigérants car il n'a pas de parties collées.
- Il est indéformable.
- Il présente un encombrement, lorsqu'il est fermé, assez réduit.
- Il peut atteindre la vitesse de 200 mt./min.
- Il n'y a à l'intérieur aucun élément métallique risquant d'endommager les guides de la machine

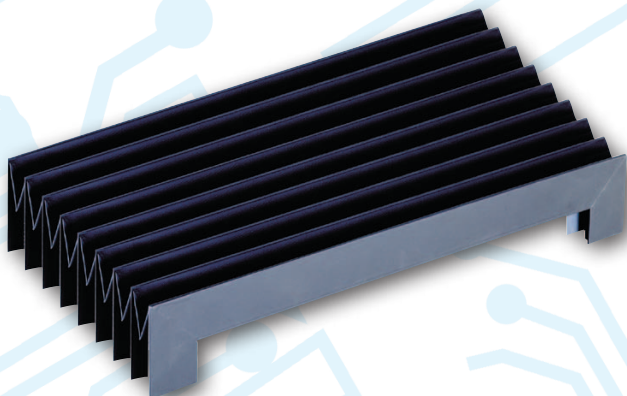

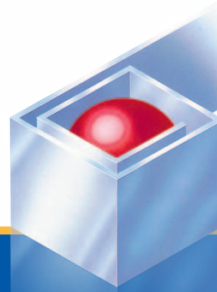
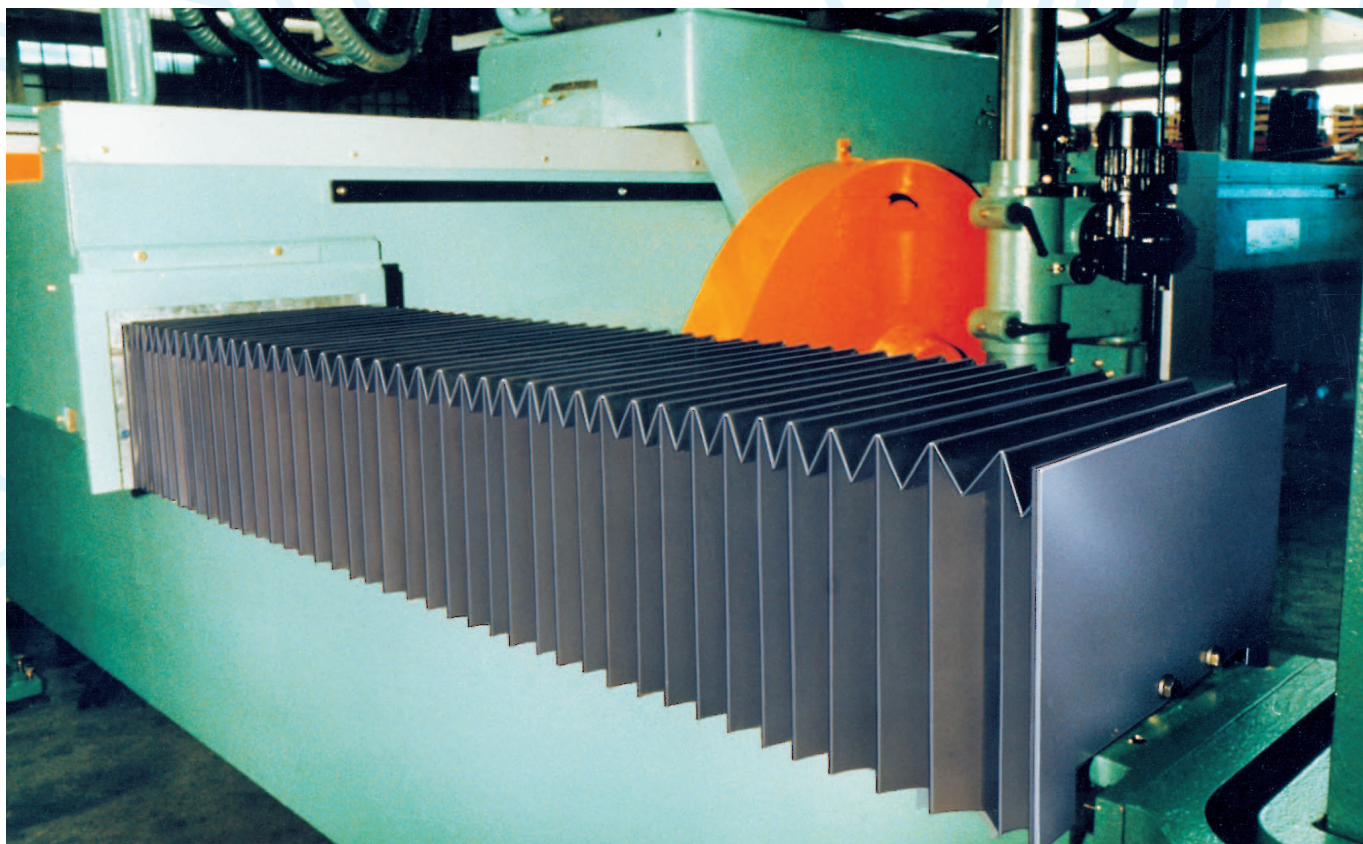
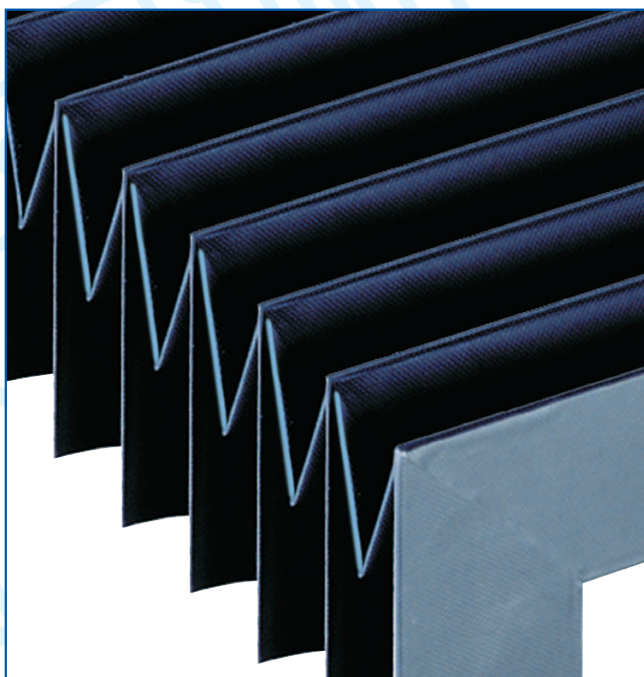
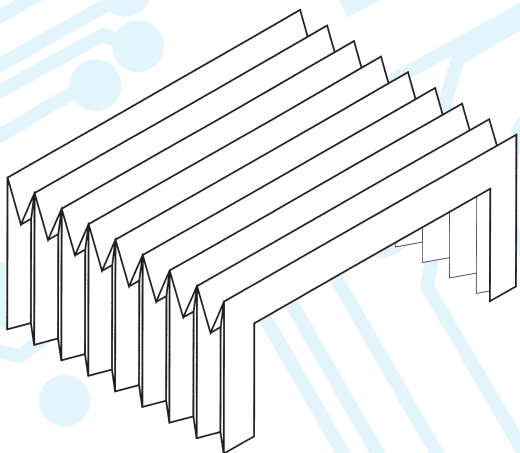

LEGENDA

- 1) Tessuto spalmato speciale, scelto in base alle condizioni di lavoro.
- 2) Supporti in PVC rigido in ogni piega.
- 3) Pattini speciali per evitare rumori fastidiosi alle alte velocità.
- 4) Saldatura ad alta frequenza.
- 5) Flange di fissaggio.

Per calcolare in fase di progettazione le dimensioni del soffiato termosaldato, è utile tener presente alcuni dati:

- le pieghe standard hanno le seguenti altezze: 15mm., 20 mm., 25 mm., 30 mm., 35 mm., 40 mm., 45 mm., 50 mm.
- il gioco complessivo tra le guide e il soffiato deve essere da un minimo di 5 mm. a un massimo di 10 mm.
- l'apertura di una piega è uguale a due volte l'altezza di una piega meno 10 mm.
- lo spessore di una piega chiusa è mediamente di 4 mm.
- il pacco chiuso del soffiato è uguale a:

$$\left(\frac{\text{apertura soffiato}}{\text{apertura una piega}} \right) \times (4 \text{ mm}). + \text{spessore flange}$$

LEGEND

- 1) Special coated fabric, chosen according to working condition.
- 2) Rigid PVC support in every fold.
- 3) Special shoes to prevent annoying noises at high speeds.
- 4) High frequency welding.
- 5) Fastening flange.

To check the size of a thermal welded bellows at a design stage, it is useful to pay attention to some calculations:

- the standard folds may have the following heights: 15mm., 20 mm., 25 mm., 30 mm., 35 mm., 40 mm., 45 mm., 50 mm.
- the total play between the slides and the bellows must be from a minimum of 5 mm. to a maximum of 10 mm.
- the extension of one fold is equivalent to twice the fold's height minus 10 mm.
- the thickness of a compressed folds is on average 4 mm.
- the compressed length of the bellows is equal to:

$$\left(\frac{\text{extension of bellows}}{\text{extension of one fold}} \right) \times (4 \text{ mm}). + \text{flange thicknesses}$$

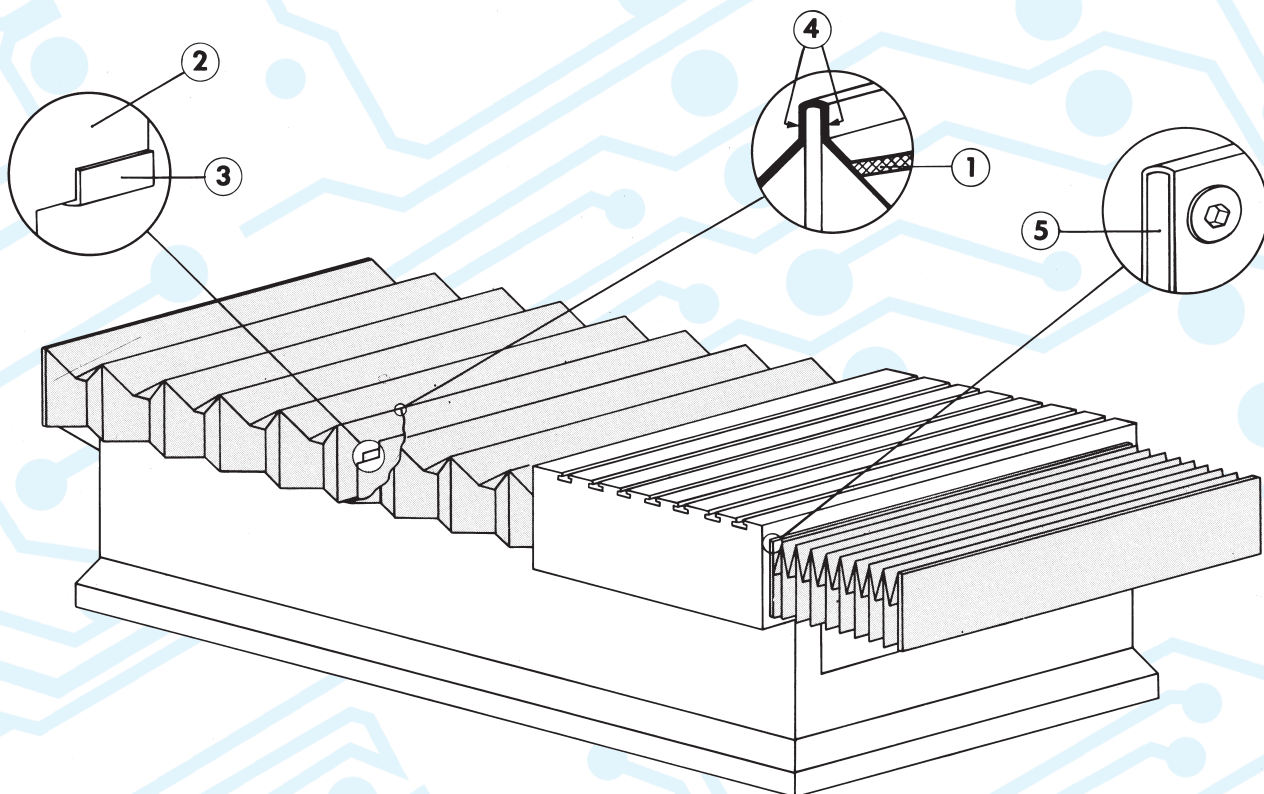

ZEICHENERKLÄRUNG

- 1) Beschichtetes Spezialgewebe gemäss den Arbeitsbedingungen.
- 2) Jede Falte mit PVC - Rahmen versteift.
- 3) Sondergleiter zur Vorbeugung von lästigen Geräuschen.
- 4) Hochfrequenzschweissung.
- 5) Befestigungsflansche.

Die Abmessungen der thermogeschweissten Bälge werden nach folgenden Daten festgelegt:

- Höhe der Standardfalten: 15mm., 20 mm., 25 mm., 30 mm., 35 mm., 40 mm., 45 mm., 50 mm.
- Gesamtspiel zwischen Führungsbahnen und Balg: min. 5 mm bis max. 10 mm
- die Spannweite einer Falte entspricht 2mal der Faltenhöhe minus 10 mm.
- Stärke einer zusammengeschobenen Falte durchschnittlich 4 mm.
- Abmessung des zusammengeschobenen Balges:

$$\left(\frac{\text{Spannweite Balg}}{\text{Spannweite Falte}} \right) \times (4 \text{ mm}) + \text{Stärke der Flansche}$$

LÉGENDE

- 1) Tissu spécial recouvert selon les conditions de travail.
- 2) Supports en PVC rigide à chaque pli.
- 3) Patins spéciaux pour éviter des bruits ennuyeux lors de grandes vitesse.
- 4) Soudure à haute fréquence.
- 5) Plaques de fixation.

Pour calculer, en phase de projet, les dimensions du soufflet thermo-soudé, il est utile de se souvenir de certaines données:

- les plis standard ont les hauteurs suivantes: 15mm., 20 mm., 25 mm., 30 mm., 35 mm., 40 mm., 45 mm., 50 mm.
- le jeu global entre les glissières et le soufflet doit être d'un minimum de 5 mm à un maximum de 10 mm
- l'ouverture d'un pli est égale à deux fois l'hauteur d'un pli, moins 10 mm.
- l'épaisseur d'un pli fermé est en moyenne de 4 mm.
- la longueur comprimée Lz du soufflet peut être calculée de façon approchée par la formule suivante

$$\left(\frac{\text{ouverture du soufflet}}{\text{ouverture d'un pli}} \right) \times (4 \text{ mm}) + \text{épaisseur de la bride}$$

TIPO TESSUTO TYPE OF FABRIC ART DES GEWEBES TYPE DE TISSU	SP. DISP. AVAIL. THICKNESS PRODUKT DICKE ÉPAISSEURS DISPONIBLES mm.	RESISTENZA ALLA TEMPERATURA RESISTANCE TO TEMPERATURE TEMPERATURBESTÄNDIGKEIT RÉSISTANCE À LA TEMPÉRATURE	RESISTENZA AGLI OLI OIL RESISTANT BESTÄNDIGKEIT GEGEN ÖLE RÉSISTANCE AUX HUILES	RESISTENZA AI SOLVENTI SOLVENTS RESISTANT BESTÄNDIGKEIT GEGEN LÖSUNGSMITTEL RÉSISTANCE AUX SOLVANTS	AUTOESTINGUENTI SELF EXTINGUISHABLE SELBSTVERLÖSCHEND AUTO-EXTINGUIBLE
TESSUTO IN POLIESTERE SPALMATO DI PVC POLYESTER FABRIC COATED WITH PVC PVC-BESCHICHTETES POLYESTERGEWEBE TISSU POLYESTER ENDUIT DE PVC	0,25 & 0,36	MAX 90°C	OTTIMA VERY GOOD AUSGEZEICHNET EXCELLENTE	MEDIA AVERAGE DURCHSCHNITT MOYENNE	SI YES YA OUI
TESSUTO IN POLIESTERE SPALMATO DI POLIURETANO POLYESTER FABRIC COATED WITH POLYURETHANE POLYESTERGEWEBE MIT POLYURETHAN BESCHICHTET TISSU DE POLYESTER ENDUIT DE POLYURÉTHANE	0,22 & 0,35	MAX 110°C	OTTIMA VERY GOOD AUSGEZEICHNET EXCELLENTE	BUONA GOOD GUT BONNE	SI/NO YES/NO
TESSUTO IN POLIESTERE SPALMATO DI NBR + TEFLON AL 12% POLYESTER FABRIC COATED WITH NBR + TEFLON AT 12% POLYESTERGEWEBE MIT NBR BESCHICHTET + 12% TEFLON TISSU DE POLYESTER ENDUIT DE NBR + TEFLON À 12%	0,35	MAX 165°C	OTTIMA VERY GOOD AUSGEZEICHNET EXCELLENTE	OTTIMA VERY GOOD AUSGEZEICHNET EXCELLENTE	NO NEIN NON
TESSUTO PREOTEX PREOTEX FABRIC	0,45	MAX 880°C	OTTIMA VERY GOOD AUSGEZEICHNET EXCELLENTE	BUONA GOOD GUT BONNE	SI YES YA OUI
TESSUTO IN NOMEX SPALMATO DI POLIURETANO NOMEX FABRIC COATED WITH POLYURETHANE NOMEXGEWEBE MIT POLYURETHAN BESCHICHTET TISSU DE NOMEX ENDUIT DE POLYURÉTHANE	0,25 & 0,38	MAX 160°C (NOMEX 350°C)	OTTIMA VERY GOOD AUSGEZEICHNET EXCELLENTE	BUONA GOOD GUT BONNE	SI YES YA OUI

🇮🇹 SOFFIETTI CON LAMELLE

🇬🇧 FINNED BELLOWS

🇩🇪 BÄLGE MIT LAMELLEN

🇫🇷 SOUFFLETS AVEC ECAILLES METALLIQUES

🇮🇹 CARATTERISTICHE

Sono stati ideati per sopportare l'urto e l'alta temperatura dei trucioli roventi (+900°).

Le lamelle di acciaio inox fissate su ogni piega del soffietto hanno questa funzione. Possono essere oscillanti o fisse.

Si applicano le oscillanti nel caso in cui il soffietto a pacco chiuso obbliga le stesse a compiere una rotazione di 90° verso l'esterno. Si applicano fisse quando a pacco chiuso il soffietto non ha alcun ostacolo e le lamelle possono mantenere la loro posizione naturale. In questo caso abbiamo una maggiore garanzia contro l'infiltrazione di piccoli trucioli tra le lamelle precaricate, grazie all'ottima aderenza tra di loro.

🇬🇧 FEATURES

They have been designed to withstand the impact of high temperature glowing chips (+900°).

The stainless steel fins fitted to each fold have this function. They can be either oscillating or fixed type. The oscillating fins are applied to those bellows which, in their compressed position, force the fins to make a 90° outward rotation. The fixed fins are applied to those bellows which, in their compressed position have no impediment so that the fins may keep their original position. In this case we have more guarantee to prevent the infiltration of small chips between the preloaded fins, due to excellent adhesion between each other.

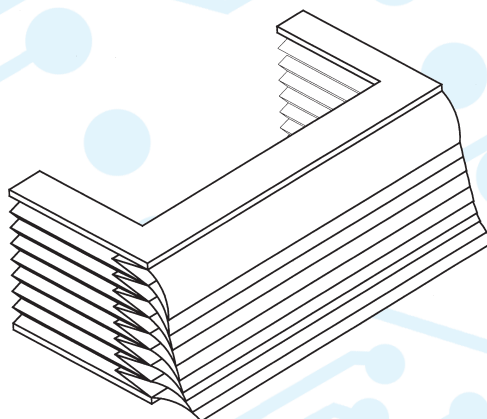
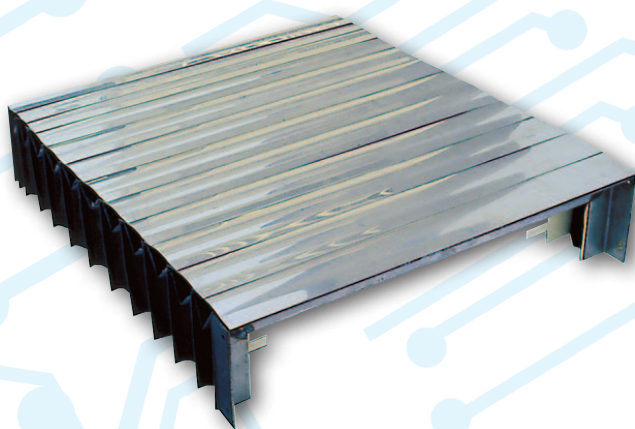

MERKMALE

Robuster Schutz gegen Stöße und heiße Späne (+900°).
Die Lamellen aus rostfreiem Stahl sind auf jeder Balgfalte befestigt.
Sie können in schwingender bzw. fester Ausführung sein.
Die schwingende Ausführung ist bevorzugt, wenn die Lamellen bei zusammengeschobenen Zustand des Balges eine Rotation um 90° nach aussen machen müssen. Die festen Lamellen werden dann eingesetzt, wenn der Balg in zusammengeschobenem Zustand nicht behindert wird. Bei den festen Lamellen, die vorgespannt dicht aneinander liegen, können zudem die feinen Späne nicht eindringen.

CARACTERISTIQUES

Ils ont été créés pour supporter les chocs et haute températures des copeaux chauds (+900°).
Les écailles en acier inox fixées sur chaque pli du soufflet assurent cette fonction. Elles peuvent être fixes ou oscillantes.
On applique les écailles oscillantes dans le cas où le soufflet en paquet fermé obligerait ces dernières à effectuer, une rotation de 90° vers l'extérieur. On met les écailles fixes quand, en paquet fermé, le soufflet ne rencontre aucun obstacle et que les écailles peuvent garder leur position naturelle. Dans ce cas, nous avons une meilleure garantie contre l'infiltration de petits copeaux entre les écailles préchargées, grâce à l'excellente adhérence entre elles.

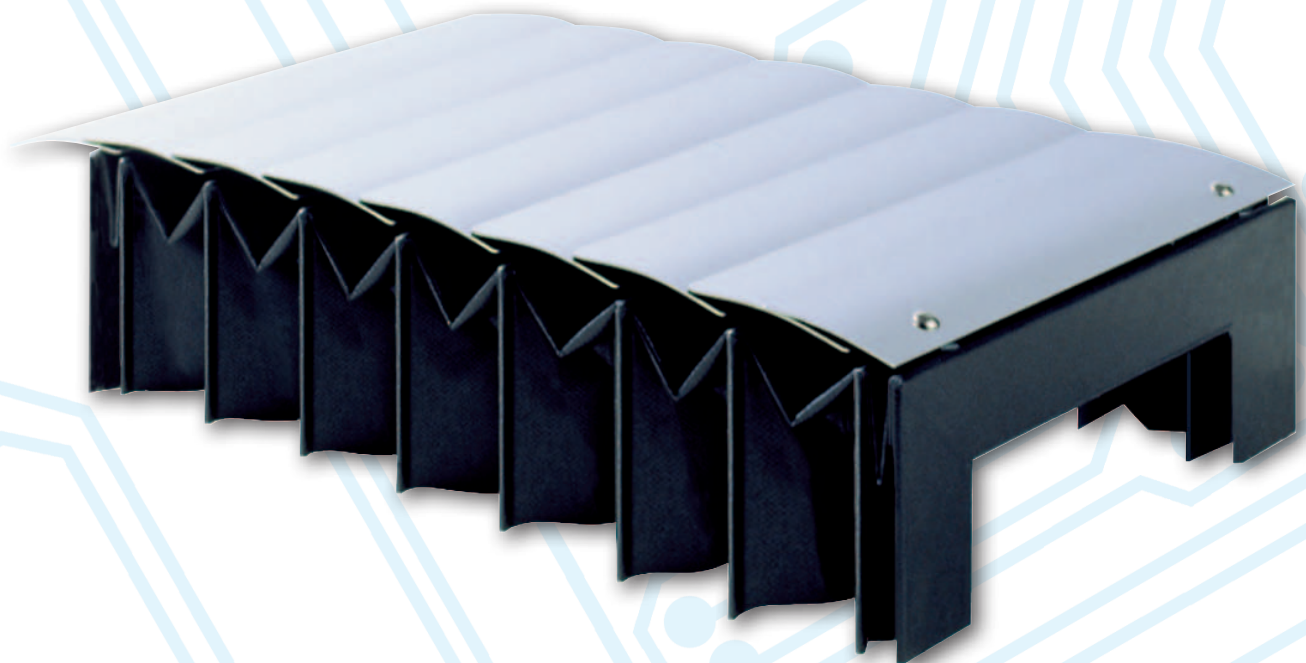

LEGENDA

- 1) Soffietto termosaldato.
- 2) Lamelle in acciaio inox.
- 3) Flange.

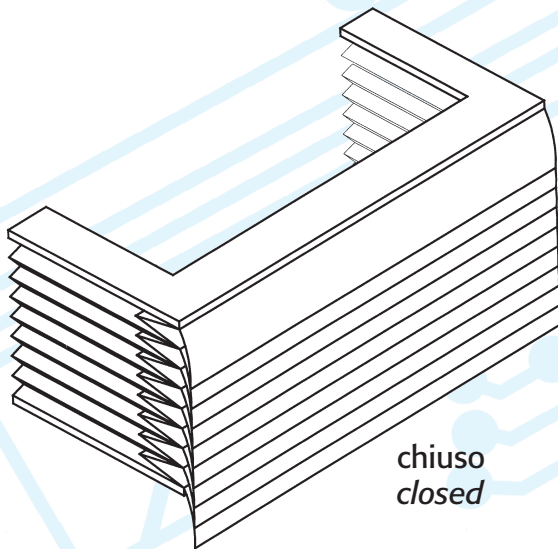

SOFFIETTO CON LAMELLE FISSE

chiuso
closed

LEGEND

- 1) Thermal welded bellow.
- 2) Stainless steel fins.
- 3) Attachment plates.

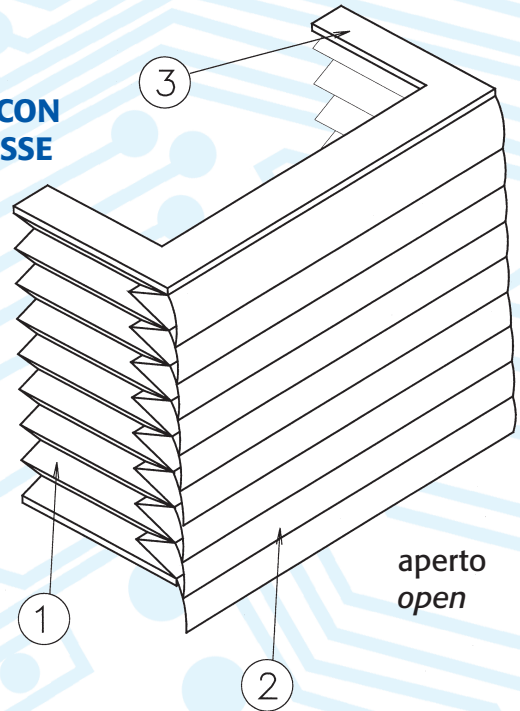

aperto
open

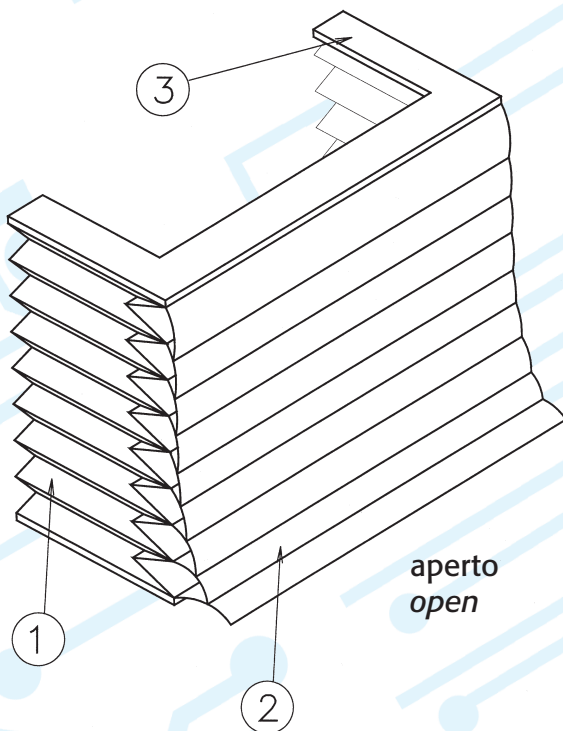

SOFFIETTO CON LAMELLE OSCILLANTI

aperto
open

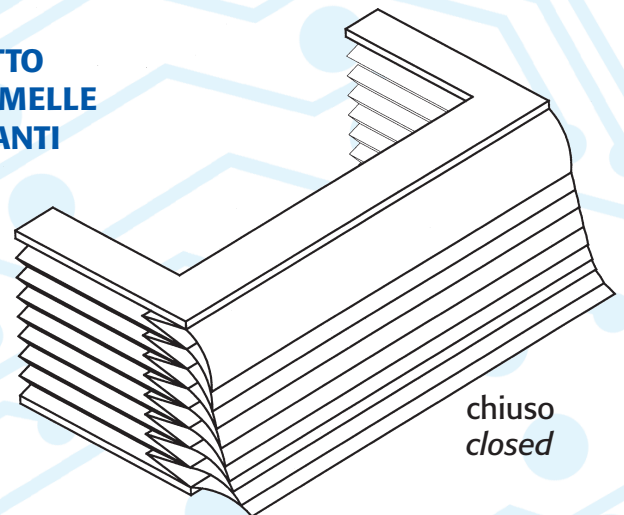

chiuso
closed

ZEICHENERKLÄRUNG

- 1) Thermogeschweisster Balg.
- 2) Lamellen aus rostfreiem Stahl.
- 3) Flansche.

LÈGENDE

- 1) Soufflet thermo-soudé.
- 2) Écailles en acier inox.
- 3) Plaques de fixation.

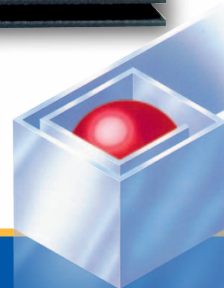
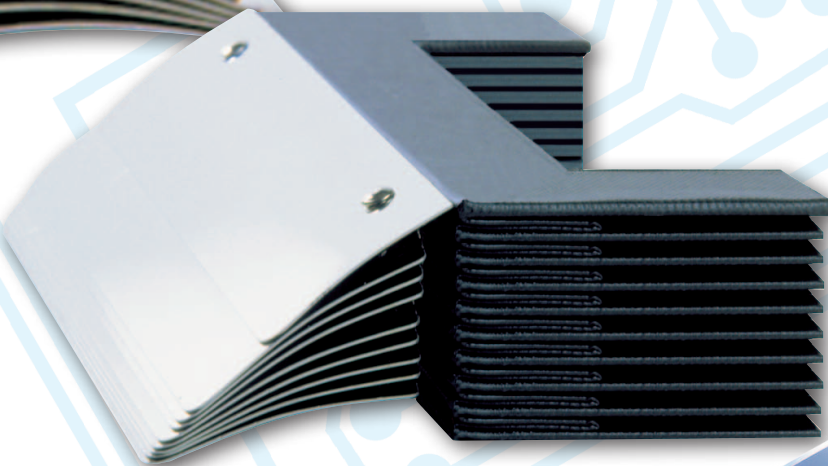
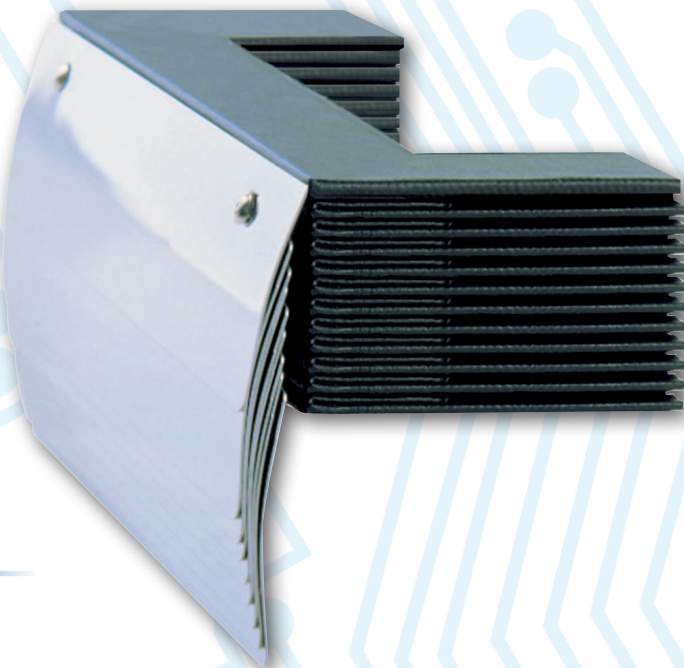

SOFFIETTI STANDARD

CARATTERISTICHE TECNICHE: sono formati da una struttura esterna a fisarmonica in tessuto e da una struttura interna portante metallica.

STANDARD BELLOWS

TECHNICAL FEATURES: they are made up of an external fabric accordion structure and inside metal supporting structure.

STANDARDBAELGE

TECHNISCHE MERKMALE: Aussenstruktur aus Gewebe und Innere Tragstruktur aus Metall.

SOUFFLETS STANDARD

CARACTERISTIQUES: Ils sont formés d'une structure externe en forme d'accordéon en tissu et d'une structure interne portante métallique.

LEGENDA

- 1) Flange di fissaggio.
- 2) Supporti intermedi in acciaio.
- 3) Pattini in ottone o nylon di guida.
- 4) Rulli di sostegno in nylon.
- 5) Pantografo ad aste e molle a strappo (vel. max. 120 mt./min.).
- 6) Profilo a forma di "U" in acciaio cromato o zincato per bloccare il soffietto al supporto.
- 7) Tessuto plastificato.
- 8) Collante poliuretano - resistente ad oli ed emulsioni.
- 9) Foglia di PVC rigido.
- 10) Tessuto plastificato.

LEGEND

- 1) Attachments plates flanges.
- 2) Steel intermediate stiffeners.
- 3) Brass or nylon guide shoes.
- 4) Nylon supporting rollers.
- 5) Rods and snatch spring pantograph (max. speed 120 mt./min.).
- 6) "U" shaped profile of chromed or galvanised steel, to secure the bellow to the support.
- 7) Plastic treated fabric.
- 8) Oil and emulsion resistant polyurethane adhesive.
- 9) Rigid PVC sheet.
- 10) Plastic treated fabric.

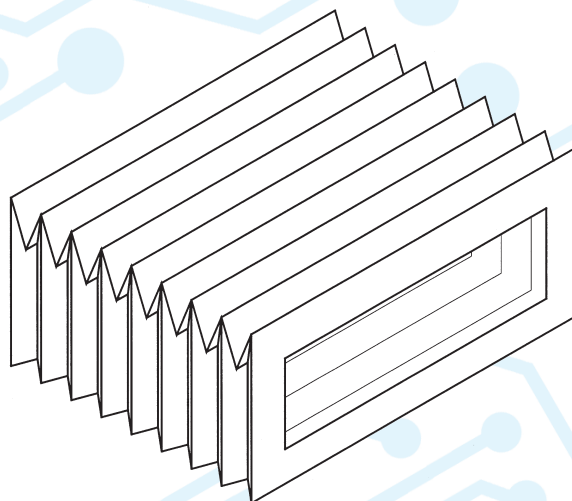
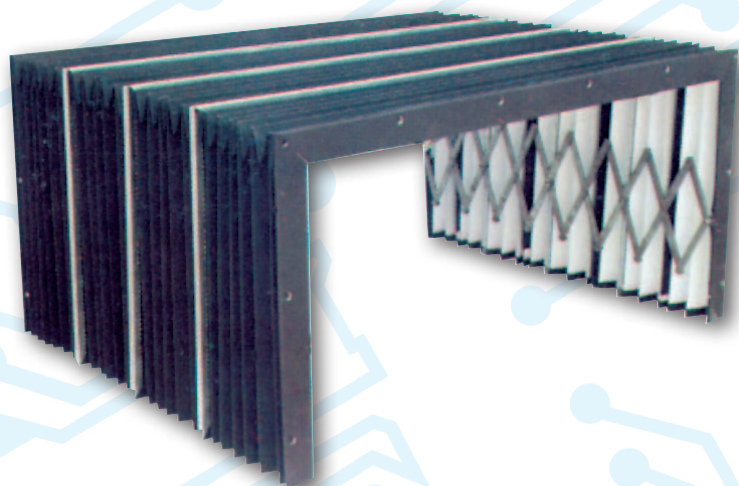

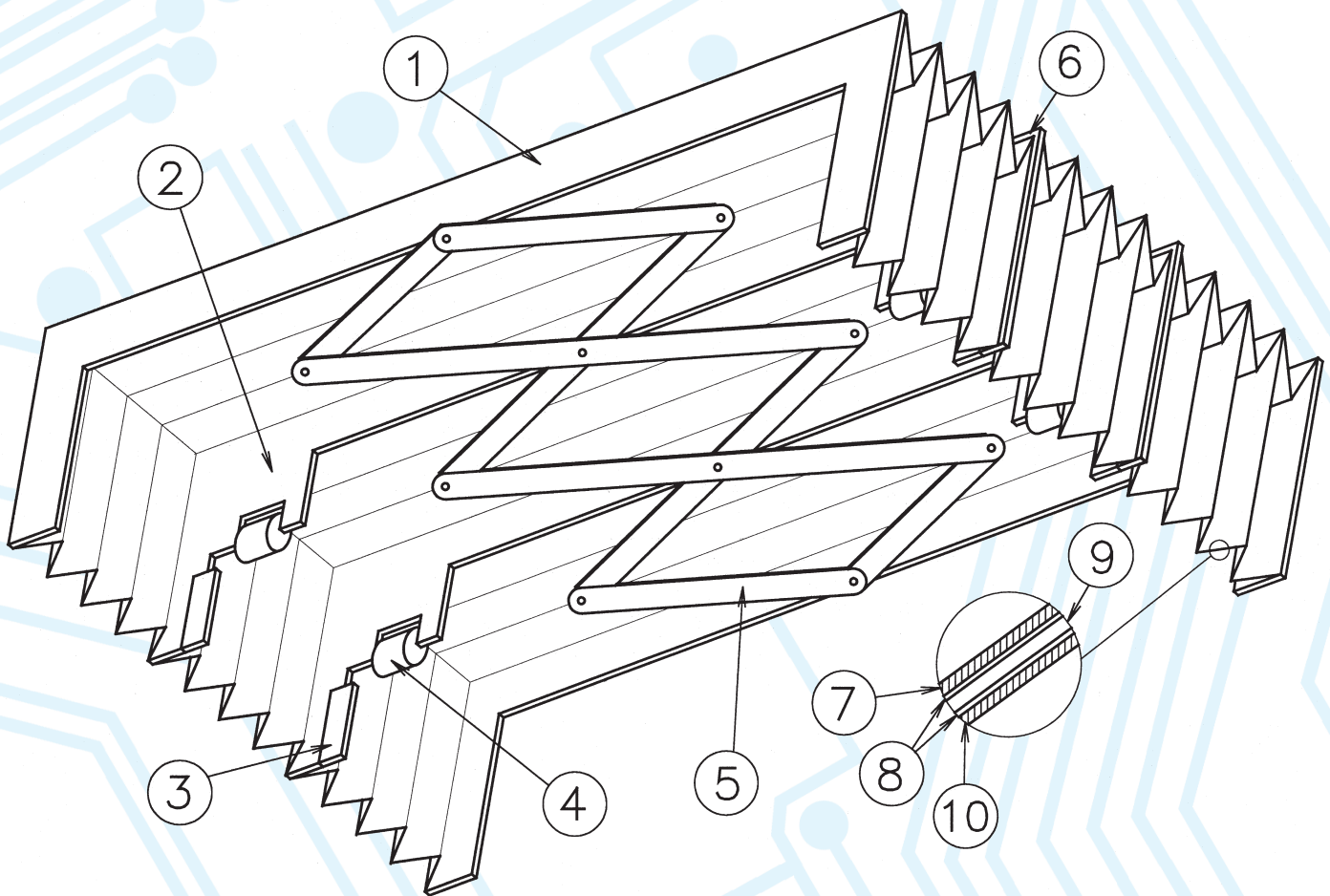

ZEICHENERKLÄRUNG

- 1) Befestigungsflansche.
- 2) Zwischensupport aus Stahl.
- 3) Messing-bzw. Nylon-Führungsgleiter.
- 4) Nylon-Stützrollen.
- 5) Stab-Pantograph mit Zugfeder. (max. Geschwindigkeit 120 mt./min.).
- 6) Profil aus verchromtem bzw. verzinktem Stahl in U-Form zur Befestigung an der Halterung.
- 7) Weichgewebe.
- 8) Polyurethankleber, Öl- und emulsionenfest.
- 9) Folie aus hartem PVC.
- 10) Weichgewebe.

LÈGENDE

- 1) Plaques de fixation.
- 2) Supports intermédiaires en acier.
- 3) Patins en laiton ou en nylon suivant glissière.
- 4) Rouleaux de soutien en nylon.
- 5) Pantographe avec barre et ressorts à secousse (vit. max. 120 mt./min.).
- 6) Profil en "U" en acier chromé ou zingué pour fixer le soufflet au support.
- 7) Tissu plastifié.
- 8) Colle polyuréthanique - résistant aux huiles et émulsions.
- 9) Feuille en PVC rigide.
- 10) Tissu plastifié.

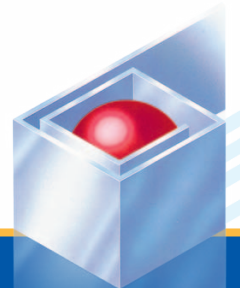

CLASSIFICAZIONE

I soffietti standard in funzione delle loro caratteristiche tecniche, sono classificati nel modo seguente:

TM / 1 esterno tessuto di poliamide resinato - colore nero - collante a base di neoprene. Supporto rigido - celflex o PVC.
Resistente alla polvere - lavora a secco.
Temp. max. +90°C -30°C.

TM / 2 esterno tessuto di poliamide spalmato di PVC. - collante poliuretano - Supporto PVC rigido.
Resistente a: acqua, olio, refrigeranti, kerosene, polvere, trucioli freddi. Temp. Max. (+90°C-100°C) -30°C.
Indicato per soffietti con un numero di 30-40 corse/ora.

TM / 3 esterno tessuto di poliamide spalmato di PVC. - collante poliuretano - Supporto PVC rigido.
Fodera di tessuto di poliamide spalmato di PVC.
Stesse caratteristiche del TM / 2.
Indicato per alte velocità 120 mt./min. e per elevato numero di corse/ora.

TM / 4 esterno tessuto di poliamide spalmato di poliuretano.
Stesse caratteristiche del TM / 2 e TM / 3.
Resistente a temp. max +130°C -40°C.

TM / 5 esterno tessuto di poliamide spalmato di NBR.
Supporto di PVC.
Collante a base di poliuretano.
Resiste bene a oli e refrigeranti.
Temp. max. 140°C.

TM / 6 esterno in fibra di kevlar alluminizzata resistente a temperature oltre i 300°C.

CLASSIFICATION

The standard bellows are classified as follows, according to their technical features:

TM / 1 external fabric made of black, resin treated polyamide - neoprene based adhesive - PVC or celflex rigid support.
Dry working and dust proof. Max. temps.: +90°C -30°C.

TM / 2 external fabric made of PVC coated polyamide - polyurethane adhesive - rigid PVC support.
resistant to: water, oil, coolants, Kerosene, dust, cold chips. Max. temps.: (+90°C-100°C) -30°C.

TM / 3 external fabric made of PVC coated polyamide - polyurethane adhesive - rigid PVC support.
Lining made of PVC coated polyamide fabric.
Same features as TM / 2. Suitable for high speeds 120mt./min. and for high number of strokes/h.

TM / 4 external fabric made of polyurethane coated polyamide.
Same features ad TM / 2 and TM / 3.
Resist to max. temps. of +130°C -40°C.

TM / 5 external fabric made of polyamide coated with NBR. PVC support. Polyurethane based adhesive. It resists well against oils and coolants. Max. temps.: 140°C.

TM / 6 external aluminized kevlar fabric resistant to temperature over 300°C.

SISTEMI DI FISSAGGIO

- 1 - ATTACCO CON PIEGA INTERA
- 2 - ATTACCO CON MEZZA PIEGA
(per fissaggio dall'esterno)
- 3 - FLANGIA SPORGENTE CON PIEGA INTERA
- 4 - ATTACCO CON VELCRO

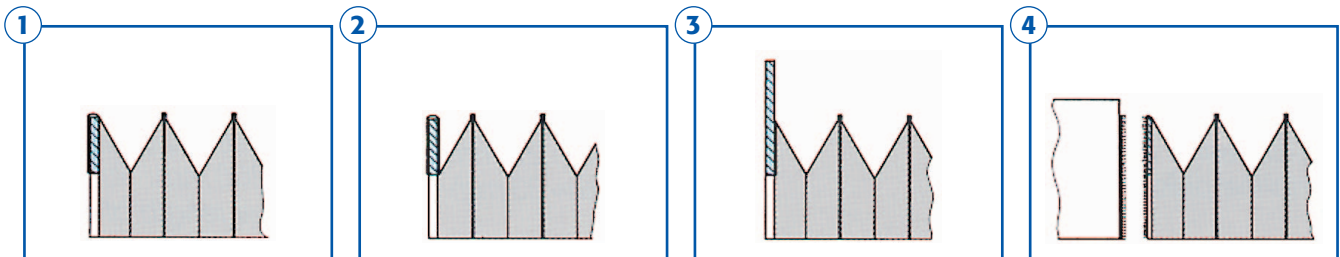

ATTACHMENT VARIATIONS

- 1 - FLANGE WITH WHOLE PLEAT
- 2 - FLANGE WITH HALF PLEAT
(for external fastening)
- 3 - PROJECTING FLANGE WITH WHOLE PLEAT
- 4 - ATTACHMENT WITH VELCRO STRIP

KLASSIFIKATION

Je nach ihren technischen Merkmalen sind die Standardbälge folgendermassen klassifiziert:

TM / 1 aussen: PVC - beschichtetes Polyamidgewebe - schwarz, Neoprenkleber.

Halterung: hartes PVC bzw. Ceflex.

Staubfest - Kaltverfahren - max. Temp. +90°C -30°C.

TM / 2 aussen: PVC - beschichtetes Polyamidgewebe, Polyurethankleber - Halterung: hartes PVC.

Fest gegen: Wasser, Öl, Kühlmittel, Kerosin, Staub, kalte Späne. Max. Temp. (+90°C-100°C) -30°C.

Geeignet an Bälgen mit 30/40 Hübe/Stunde.

TM / 3 aussen: PVC-beschichtetes Polyamidgewebe, Polyurethankleber. Halterung: hartes PVC. Futter aus PVC - beschichtetes Polyamidgewebe - Gleiche Eigenschaften wie bei TM / 2 - Geeignet bei hohen Geschwindigkeiten: 120 mt./min. und hoher Taktanzahl pro Stunde.

TM / 4 aussen: Polyurethan- beschichtetes Polyamidgewebe, Eigenschaften wie bei TM / 2 und TM / 3 - max. Temp. +130°C -40°C.

TM / 5 aussen: NBR - Beschichtetes Polyamidgewebe. PVC - Halterung - Kleber basiert auf Polyurethan. Gute Öl - und Kühlmittelbeständigkeit. Max. Temperatur 140°C.

TM / 6 aussen: aluminisierte Kevlarfiber beständig bei temperaturen über 300°C.

CLASSIFICATION

Les soufflets standards, en fonction de leurs caractéristiques techniques, se classent de la façon suivante:

TM / 1 extérieur en tissu de polyamide résiné - couleur noire colle à base de néoprène. Support rigide - celflex ou PVC

Résistant à la poussière - il travaille à sec. Temp. max. +90°C -30°C.

TM / 2 extérieur en tissu de polyamide recouvert de PVC. Colle polyuréthanique - Support en PVC rigide.

Résistant à: eau, huile, réfrigérants, chérosène, poussière, copeaux froids. Temp. Max. (+90°C-100°C) -30°C.

Indiqué pour des soufflets avec un nombre de 30 - 40 courses/heure.

TM / 3 extérieur en tissu de polyamide recouvert de PVC colle polyuréthanique - Support en PVC rigide. Doublure en tissu de polyamide recouvert de PVC. Mêmes caractéristiques que le TM/2.

Indiqué pour les grandes vitesses 120 mt./min. et pour un nombre élevé de courses par heure.

TM / 4 extérieur en tissu de polyamide recouvert de polyuréthane.

Mêmes caractéristique que le TM/2 et TM/3. Résistant à des temp. max. +130°C -40°C.

TM / 5 extérieur en tissu de polyamide recouvert de NBR. Support en PVC.

Colle à la base de polyuréthane.

Il résiste bien aux huiles et aux réfrigérants.

Temp. max. 140°C.

TM / 6 extérieur en fibre de kevlar aluminisée qui résiste à une température supérieure à 300°C.

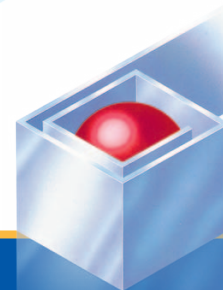
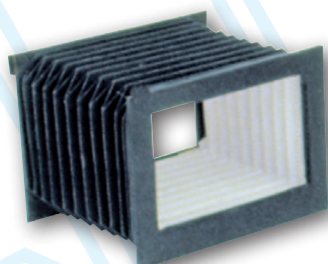
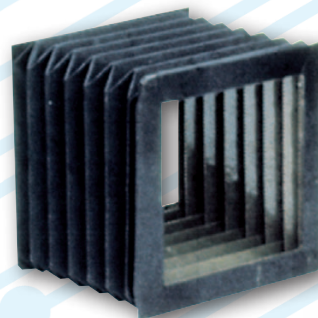
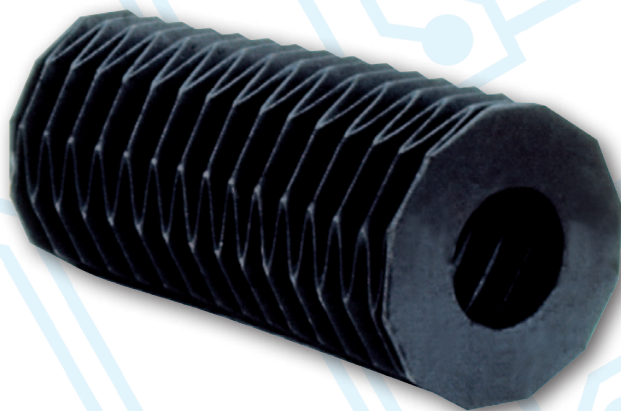

🇮🇹 SOFFIETTI TUBOLARI CUCITI O TERMOSALDATI

🇬🇧 TUBULAR SEWN OR THERMAL WELDED BELLOWS

🇩🇪 FALTENBÄLGE RUNDGENÄHT ODER THERMOGESCHWEISST

🇫🇷 SOUFFLETS TUBULAIRES COUSUS OU SOUDÉS

🇮🇹 CARATTERISTICHE

- Ideali per protezione viti, alberi, colonne, contro qualsiasi tipo di agente esterno.
- La versione termosaldata è perfettamente impermeabile.
- Resistono agli urti e sono indeformabili.
- Quando lavorano in posizione orizzontale sono forniti con pattini per impedire alle spire d'infilarci nei filetti della vite.

🇬🇧 FEATURES

- Ideal for protecting lead screws, shafts and columns against any type of external agent.
- The welded version is perfectly waterproof.
- They are impact resistant and crush-proof.
- With horizontal mounting, they are fitted with shoes to prevent the spiral from getting trapped in the lead screws threads.

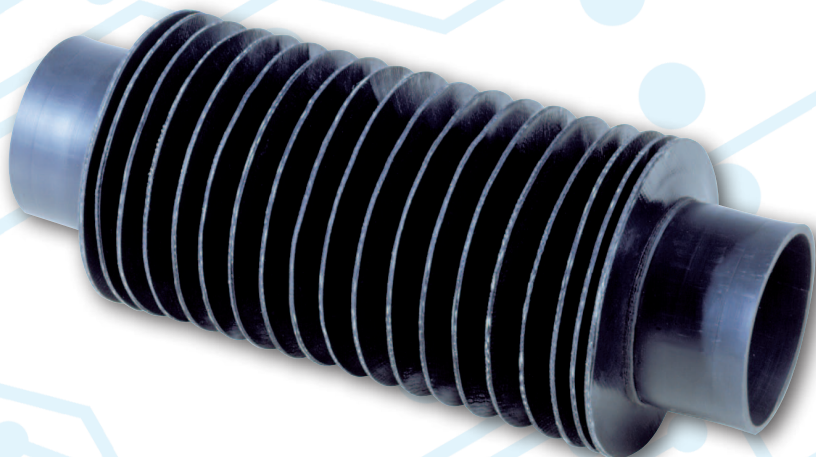
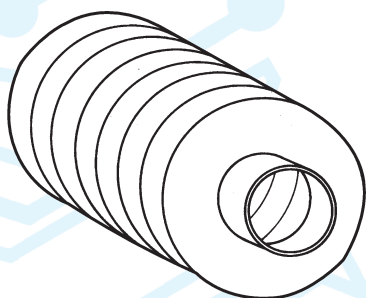
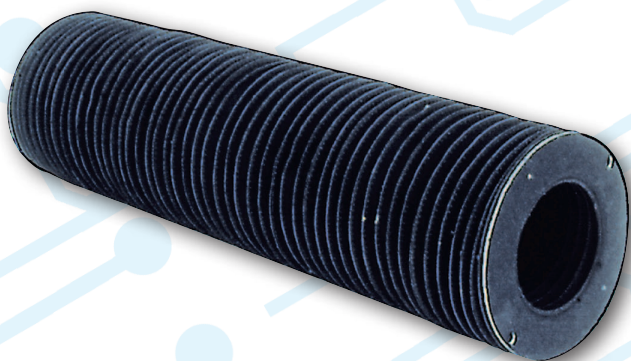

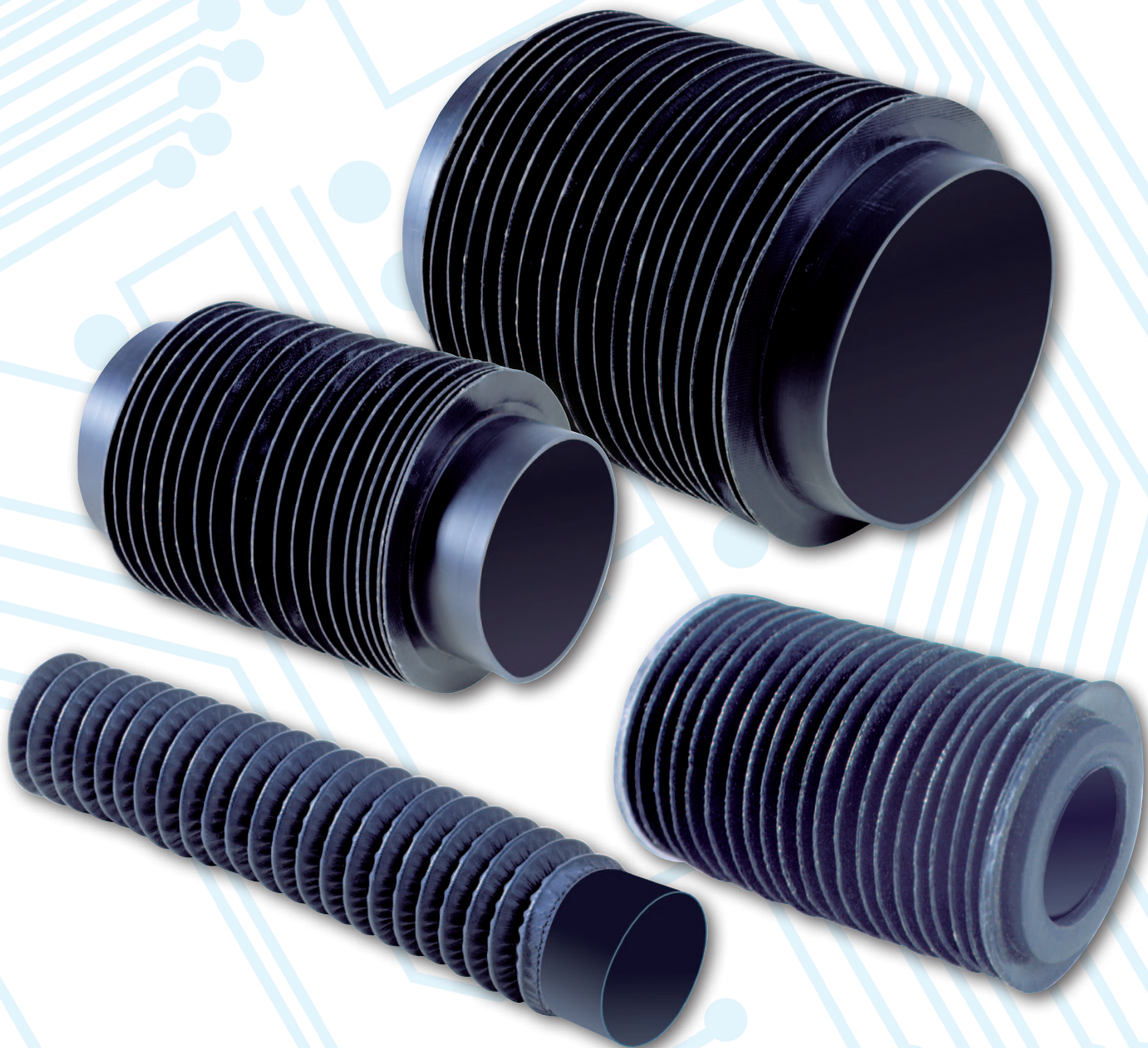

MERKMALE

- Besonders geeignet als Schutz für Schrauben, Wellen, Säulen und gegen jegliche Art von Fremdkörpern.
- Thermogeschweisst sind sie vollkommen dicht.
- Stossfest und unverformbar.
- Bei horizontalem Einsatz sind sie mit Gleitern versehen, um das Eindringen der Windungen in das Schraubengewinde zu vermeiden.

CARACTÉRISTIQUES

- Ils sont idéaux pour la protection de vis, d'arbres, de colonnes, contre n'importe quel type d'agent externe.
- Dans la version thermosoudée, ils sont parfaitement imperméables.
- Ils résistent aux chocs et sont indéformables.
- Quand ils travaillent en position horizontale, ils sont livrés avec des patins pour empêcher aux spires de se prendre dans les filets des vis.



LEGENDA

- 1) Anelli in poliammide rigido o kevlar spalmato su ambo i lati.
- 2) Cucitura o saldatura.
- 3) Pattini di sostegno in PVC.
- 4) Anelli di acciaio per soffietti di grandi dimensioni.
- 5) Flangia piatta.
- 6) Collare.

Possiamo fornirli in qualsiasi dimensione e diametro senza addebitare spese di attrezzature poiché il taglio degli anelli viene effettuato con impianto laser a CN.

È molto importante durante la fase di progettazione, dimensionare l'altezza della

piega: $\frac{B-A}{2}$ almeno 15 mm. (vedi pag. 9)

Lo spessore di una piega varia da 1,2 mm a 1,8 mm. L'apertura di una piega è uguale all'altezza di una piega - 3 mm.

Il pacco chiuso del soffietto è uguale a:

$$\left(\frac{\text{apertura soffietto}}{\text{apertura una piega}} \right) = \text{N}^\circ \text{ pieghe} \times \text{spessore di una piega}$$

LEGEND

- 1) Rigid polyamide or kevlar rings coated on both sides.
- 2) Seams or weldings.
- 3) PVC supporting shoes.
- 4) Steel rings for the large bellows.
- 5) Flat attachment plate.
- 6) Collar.

We are able to supply them in any diameter without charging extra tooling costs because the rings are cut with an NC laser system.

At a design stage, it is very important to dimension the height of the fold:

$\frac{B-A}{2}$ at least 15 mm. (see page 9).

The extension of one fold varies between 1,2 mm and 1,8 mm.

The extension of one fold is equivalent to the height of one fold minus 3 mm.

The compressed length of the bellows is equivalent to:

$$\left(\frac{\text{extension of bellows}}{\text{extension of one fold}} \right) = \text{no. of folds} \times \text{thickness of one fold}$$

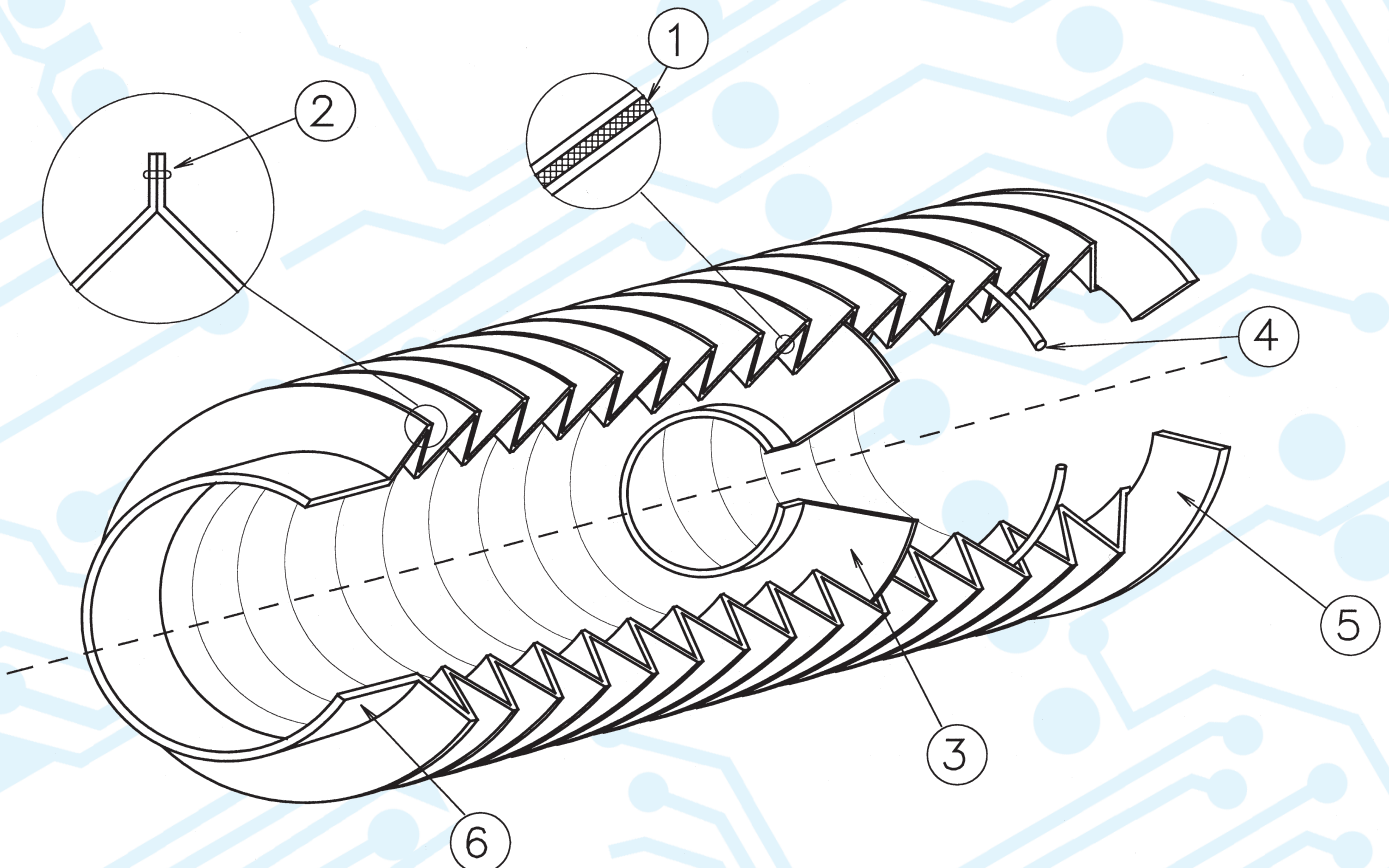

ZEICHENERKLÄRUNG

- 1) Ringe aus beidseitig beschichtetem hartem Polyamid oder kevlar.
- 2) Naht oder Schweissnaht.
- 3) Stützgleiter aus PVC.
- 4) Stahlringe bei grossdimensionierten Bälgen.
- 5) Flacher Flansch.
- 6) Bund.

In jeder gewünschten Durchmessergrösse ohne Preisunterschied verfügbar, da die Ringe in einer CN Anlage zugeschnitten werden. Bei der Planung ist die Dimensionierung der Falte von grösster Bedeutung:

$\frac{B-A}{2}$ mindestens 15 mm. (siehe Seite 9)

Die Stärke der Falte variiert zwischen 1,2 - 1,8 mm.

Die Spannweite der Falte entspricht der Faltenhöhe minus 3 mm.

Im zusammengeschobenem Zustand haben wir:

$$\left(\frac{\text{Spannweite Balg}}{\text{Spannweite einer Falte}} \right) = \text{Faltenanzahl} \times \text{Faltenstärke}$$

LÉGENDE

- 1) Anneaux en polyamide ou kevlar rigide recouvert des deux côtés.
- 2) Coutures ou soudures.
- 3) Patins de soutien en PVC.
- 4) Anneaux en acier pour soufflets de grandes dimensions.
- 5) Bride plate.
- 6) Collier.

Nous pouvons les livrer dans n'importe quelle dimension et diamètre sans supplément car la coupe des anneaux se fait avec une machine à CN.

Il est très important en phase de projet, de dimensionner l'hauteur du pli:

$\frac{B-A}{2}$ d'au moins 15 mm. (voire à la page 9)

L'épaisseur d'un pli varie de 1,2 à 1,8 mm.

L'ouverture d'un pli est égale à la hauteur d'un pli - 3 mm.

La hauteur comprimée du soufflet est égal à:

$$\left(\frac{\text{ouverture du soufflet}}{\text{ouverture d'un pli}} \right) = \text{nombre de plis} \times \text{épaisseur d'un pli}$$

TIPO TESSUTO TYPE OF FABRIC ART DES GEWEBES TYPE DE TISSU	SP. DISP. AVAIL. THICKNESS PRODUKT DICKE ÉPAISSEURS DISPONIBLES mm.	RESISTENZA ALLA TEMPERATURA RESISTANCE TO TEMPERATURE TEMPERATURBESTÄNDIGKEIT RÉSISTANCE À LA TEMPÉRATURE	RESISTENZA AGLI OLII OIL RESISTANT BESTÄNDIGKEIT GEGEN ÖLE RÉSISTANCE AUX HUILES	RESISTENZA AI SOLVENTI SOLVENTS RESISTANT BESTÄNDIGKEIT GEGEN LÖSUNGSMITTEL RÉSISTANCE AUX SOLVANTS	AUTOESTINGUENTI SELF EXTINGUISHABLE SELBSTVERLÖSCHEND AUTO-EXTINGUIBLE
TESSUTO IN POLIESTERE SPALMATO DI PVC POLYESTER FABRIC COATED WITH PVC PVC-BESCHICHTETES POLYESTERGEWEBE TISSU POLYESTER ENDUIT DE PVC	0,25 0,36 0,6 0,8	MAX 90°C	OTTIMA VERY GOOD AUSGEZEICHNET EXCELLENTE	MEDIA AVERAGE DURCHSCHNITT MOYENNE	SI YES YA OUI
TESSUTO IN POLIESTERE SPALMATO DI POLIURETANO POLYESTER FABRIC COATED WITH POLYURETHANE POLYESTERGEWEBE MIT POLYURETHAN BESCHICHTET TISSU DE POLYESTER ENDUIT DE POLYURÉTHANE	0,22 0,33 0,6	MAX 110°C	OTTIMA VERY GOOD AUSGEZEICHNET EXCELLENTE	BUONA GOOD GUT BONNE	SI YES YA OUI
TESSUTO IN POLIESTERE SPALMATO DI NBR + TEFLON AL 12% POLYESTER FABRIC COATED WITH NBR + TEFLON AT 12% POLYESTERGEWEBE MIT NBR BESCHICHTET + 12% TEFLON TISSU DE POLYESTER ENDUIT DE NBR + TEFLON À 12%	0,6 0,9	MAX 165°C	OTTIMA VERY GOOD AUSGEZEICHNET EXCELLENTE	OTTIMA VERY GOOD AUSGEZEICHNET EXCELLENTE	NO NEIN NON
TESSUTO IN FIBRA DI VETRO ALLUMINIZZATA ALUMINIZED FIBER-GLASS FABRIC ALUMINISIERTE GLASFASERGEWEBE TISSU DE VERRE ALUMINISÉ	0,6	MAX 400°C	OTTIMA VERY GOOD AUSGEZEICHNET EXCELLENTE	OTTIMA VERY GOOD AUSGEZEICHNET EXCELLENTE	SI YES YA OUI
TESSUTO IN KEVLAR ALLUMINIZZATO ALUMINIZED KEVLAR FABRIC ALUMINISIERTE GLASFASERGEWEBE TISSU DE VERRE ALUMINISÉ	0,25 0,8	MAX 400°C	OTTIMA VERY GOOD AUSGEZEICHNET EXCELLENTE	OTTIMA VERY GOOD AUSGEZEICHNET EXCELLENTE	SI YES YA OUI
TESSUTO SILTEMP SILTEMP FABRIC SILTEMP GEWEBE TISSU SILTEMP	0,6	MAX 1200°C	OTTIMA VERY GOOD AUSGEZEICHNET EXCELLENTE	OTTIMA VERY GOOD AUSGEZEICHNET EXCELLENTE	SI YES YA OUI

🇮🇹 SOFFIETTI ROTONDI IN GOMMA

🇬🇧 ROUND RUBBER BELLOWS

🇩🇪 RUNDE GUMMI FALTENBÄLGE

🇫🇷 SOUFFLETS ROUNDS EN CAOUTCHOUC

🇮🇹 CARATTERISTICHE

- Assolutamente impermeabili
- Protezione affidabile contro l'acqua, olio, emulsioni e prodotti chimici (NBR)
- Protezione contro gli agenti atmosferici e raggi UV (HYPALON)
- Vasta gamma di diametri e lunghezze disponibili.

🇬🇧 FEATURES

- Absolutely leakproof
- Reliable protection against water, oil, emulsions and chemicals (NBR)
- Weather-proof and resistant to UV radiation
- Wide range of diameters and lengths

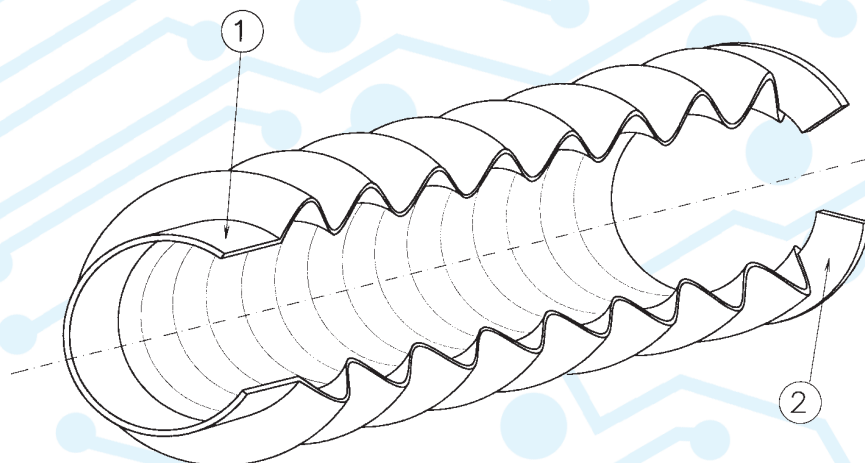
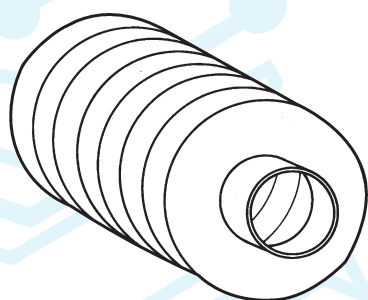

- 1) Collare - collar
2) Flangia - att. plate



MERKMALE

- Absolut dicht
- Zuverlässiger Schutz gegen Wasser, Öl, Emulsionen und Chemikalien (NBR)
- Witterungs- und UV-beständig
- Verfügbar in verschiedenen Durchmessern und Längen

CARACTÉRISTIQUES

- Absolument impénétrables
- Protection fiable contre l'eau, les huiles, les émulsions et les composés chimiques (NBR)
- Protections contre les agents atmosphériques et rayons UV (HYPALON)
- Grande gamme de diamètres et longueurs

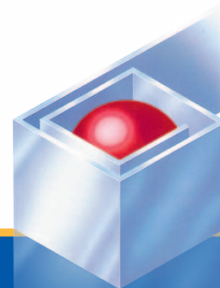

🇮🇹 SOFFIETTI PIANI CON LAMELLE TELESCOPICHE
🇬🇧 PLAIN BELLOWS WITH TELESCOPIC SHEETS
🇩🇪 FALTENBALGJALOUSIE MIT TELESKOPBLECHEN
🇮🇹 SOUFFLETS PLANS AVEC ÉCAILLES TÉLESCOPIQUES

🇮🇹 CARATTERISTICHE

- Lamelle telescopiche montate a cerniera.
- Poco spazio richiesto.
- Protezione affidabile contro grosse quantità di trucioli.
- Le lamelle telescopiche sono facili da rimpiazzare.
- Giunzioni con colla assenti.

🇬🇧 FEATURES

- Hinged mounted telescopic sheets.
- Small space requirement.
- Reliable protection against large amount of chip.
- Individual telescopic sheets are easy to replace.
- No glued joints.

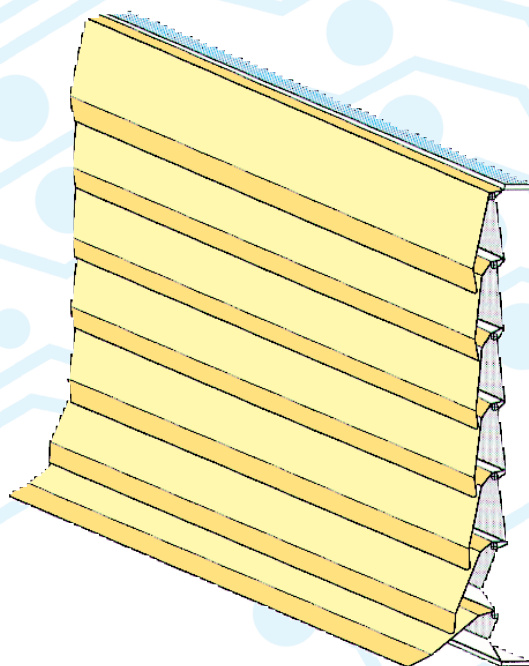

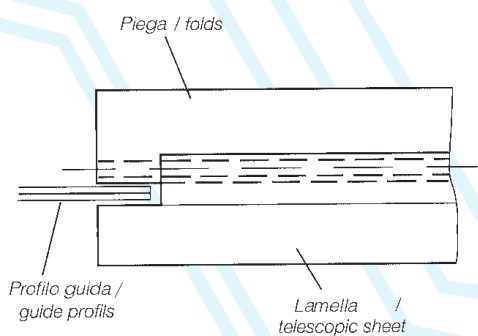
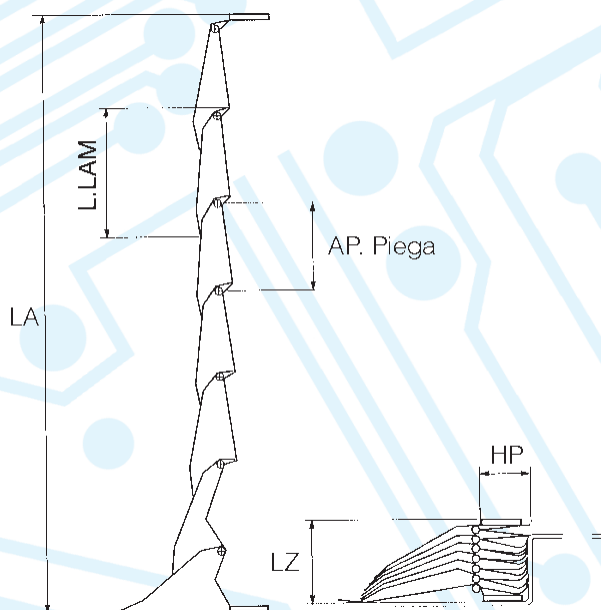

MERKMALE

- Gelenkig montierte Teleskopbleche.
- Geringer Platzbedarf.
- Sicherer Schutz bei hohem Späneanfall.
- Problemloser Austausch einzelner Teleskopbleche.
- Keine Klebeverbindungen.

CARATTERISTICHE

- Écailles télescopiques fixées par charnière.
- Peu d'espace nécessaire.
- Protection fiable contre les grandes quantités de copeaux.
- Il est très facile de remplacer les écailles.
- Pas de collage.

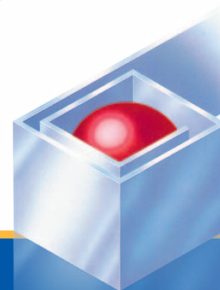

🇮🇹 SOFFIETTI CON PROTEZIONE TELESCOPICA SU TRE LATI
🇬🇧 BELLOWS WITH TELESCOPIC SHEETS ON THREE SIDES
🇩🇪 FALTENBALG MIT 3-SEITEN TELESKOPBLECHEN
🇮🇹 SOUFFLETS AVEC PROTECTEUR TELESCOPIQUE SUR TROIS CÔTÉS

🇮🇹 CARATTERISTICHE

- I lati esteriori del soffietto sono completamente protetti.
- La protezione telescopica in acciaio può essere sostituita.
- Costruzione più leggera rispetto alle protezioni telescopiche, permettendo velocità lineari più elevate.
- Semplice installazione e rimozione.

Ogni piega è supportata da un telaio di plastica per incontrare richieste specifiche. In aggiunta i lati esterni sono protetti da protezione telescopica bi o tri-dimensionale.

🇬🇧 FEATURES

- The outer sides of the bellows are either protected.
- Replacement for steel telescopic covers.
- Lighter construction than telescopic way covers allowing higher linear speeds.
- Simple installation and removal.

Each crease is supported by a plastic frame shaped to meet the specific requirements. In addition the outer sides of the bellows are protected with three dimensional telescopic cover.

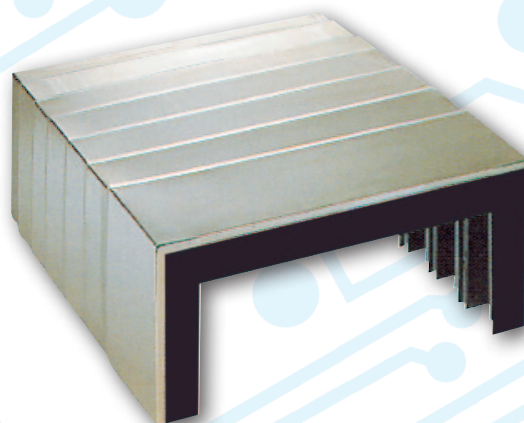
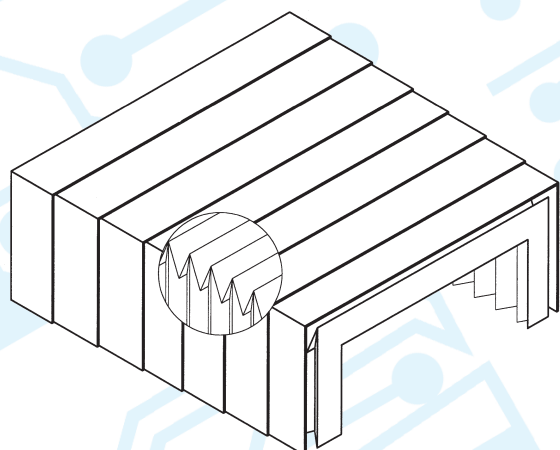
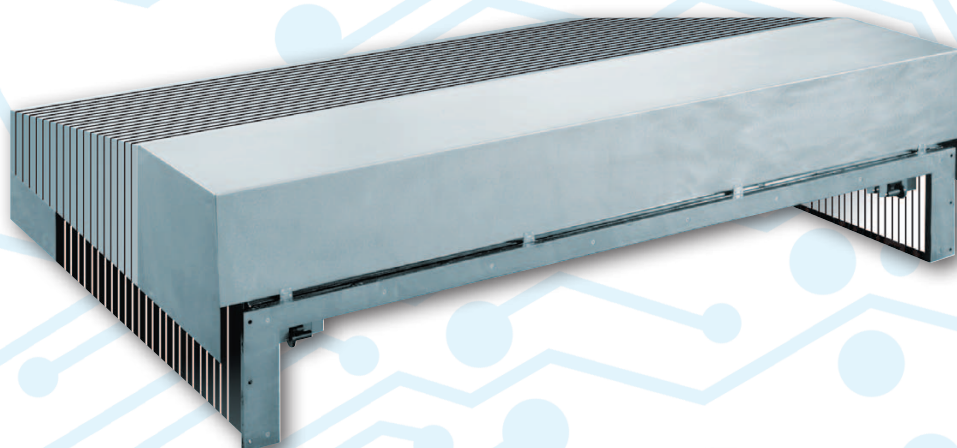

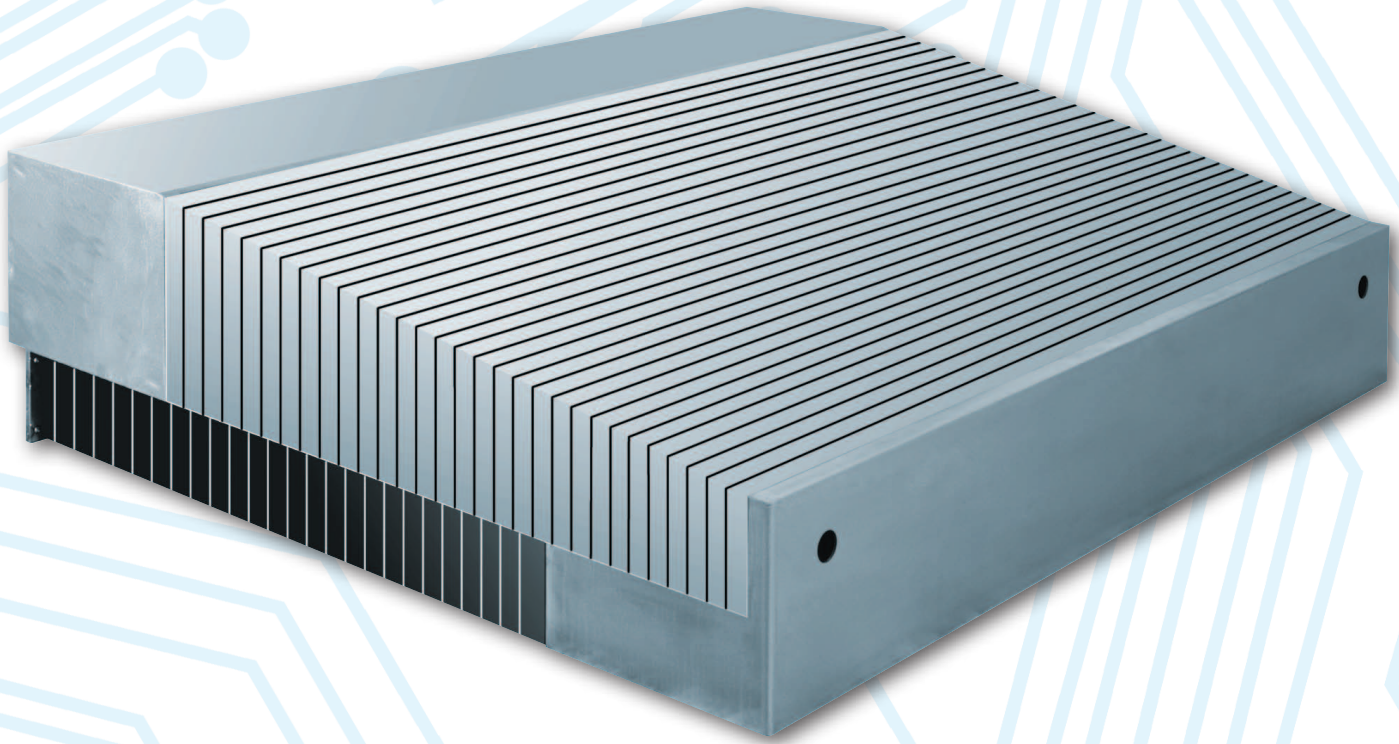

MERKMALE

- Schützt zusätzlich die Aussenseiten des Faltenbalges.
- Ersatz für einfache Teleskopabdeckungen.
- Die leichtere Bauweise gegenüber Teleskopabdeckungen ermöglicht höhere Verfahrgeschwindigkeiten.
- Einfache Montage und Demontage.

Jede Falte wird durch einen Kunststoffrahmen, dessen Form auftragsspezifisch ist, abgestützt. Zusätzlich sind hier die Balgaussenseiten mit 2- oder 3-dimensional geformten Teleskopblechen versehen.

CARACTÉRISTIQUES

- Les côtés extérieurs du soufflet sont protégés aussi.
- Remplacement pour de protecteurs télescopiques.
- Construction plus légère que les protecteurs télescopiques permettant des vitesses plus élevées et un encombrement plus faible.
- Installation et remplacement simples.

Chaque plie est supportée par une structure en plastique qui est formée suivant les besoins spécifiques. Les parties extérieures peuvent être protégées par une protection télescopique sur deux ou trois côtés.



 **SOFFIETTI PLASTICMETAL®**

 **PLASTICMETAL® BELLOWS**

 **PLASTICMETAL® FALTENBALG**

 **SOUFFLETS PLASTICMETAL®**

CARATTERISTICHE

Le macchine utensili moderne impiegano motori evoluti e tecnologie raffinate che determinano velocità ed accelerazioni elevatissime.

Proteggere le guide e gli organi di trasmissione diventa difficile con i prodotti tradizionali.

TECNIMETAL sempre proiettata nel futuro, ha risolto questi problemi e presenta:

SOFFIETTO PLASTICMETAL® LIGHT

Velocità max 240 MTmin

Accelerazione 2 G

Rumorosità 30 DEC

SOFFIETTO PLASTICMETAL® STRONG

Velocità max 240 MTmin

Accelerazione 2 G

Rumorosità 30 DEC

FEATURES

Contemporary machine tools are fitted up with advanced motors and sophisticated technologies which bring them up to high speeds and accelerations.

Protection of railings and transmission devices becomes difficult with ordinary products.

TECNIMETAL always projected into the future, has worked out these problems and presents:

PLASTICMETAL® LIGHT BELLOW

Max. speed 240/mts x min.

Acceleration 2G

Noise rate: 30 Dec.

PLASTICMETAL® STRONG BELLOW

Max. speed 240/mts x min.

Acceleration 2G

Noise rate: 30 Dec.

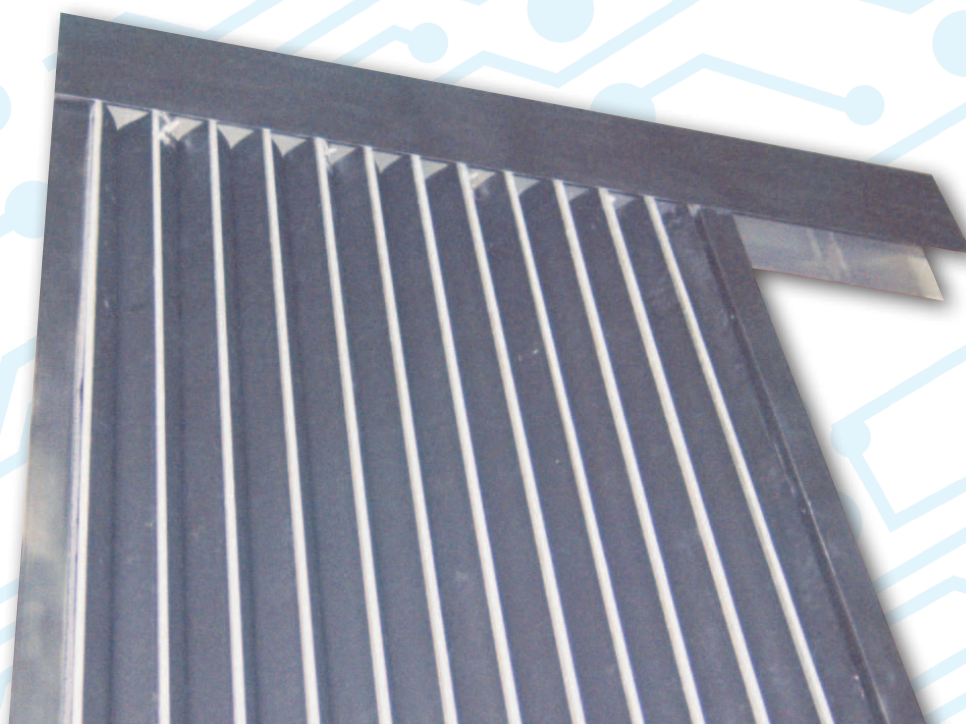

MERKMALE

Die moderne Werkzeugmaschine benutzen fortgeschrittene Motoren und verfeinerte Technologien, die sehr hohe Geschwindigkeiten und Beschleunigungen auslösen.

Es wird schwierig, Führungen und Antriebe mit überlieferten Produkten zu schweißen.

TECNIMETAL, die immer an der Spitze steht, hat diese Probleme gelöst und stellt zwei neue Faltenbälge vor:

PLASTICMETAL® LIGHT FALTENBALG

max Geschwindigkeit 240 MT min

Beschleunigung 2 G

Lautheit 30 DEC

PLASTICMETAL® STRONG FALTENBALG

max Geschwindigkeit 240 MT min

Beschleunigung 2 G

Lautheit 30 DEC

CARACTÉRISTIQUES

Les machines-outils modernes utilisent des moteurs évolués et des technologies raffinées qui déterminent des vitesses et des accélérations très élevées.

Il est donc difficile de protéger les glissières et les organes de transmission avec les moyens traditionnels.

TECNIMETAL, toujours projetée dans le futur, a trouvé une solution à ces problèmes et présente:

SOUFFLET PLASTICMETAL® LIGHT

Vitesse 240 Mt/min maxi

Accélération 2 G

Bruit 30 DEC

SOUFFLET PLASTICMETAL® STRONG

Vitesse 240 Mt/min maxi

Accélération 2 G

Bruit 30 DEC

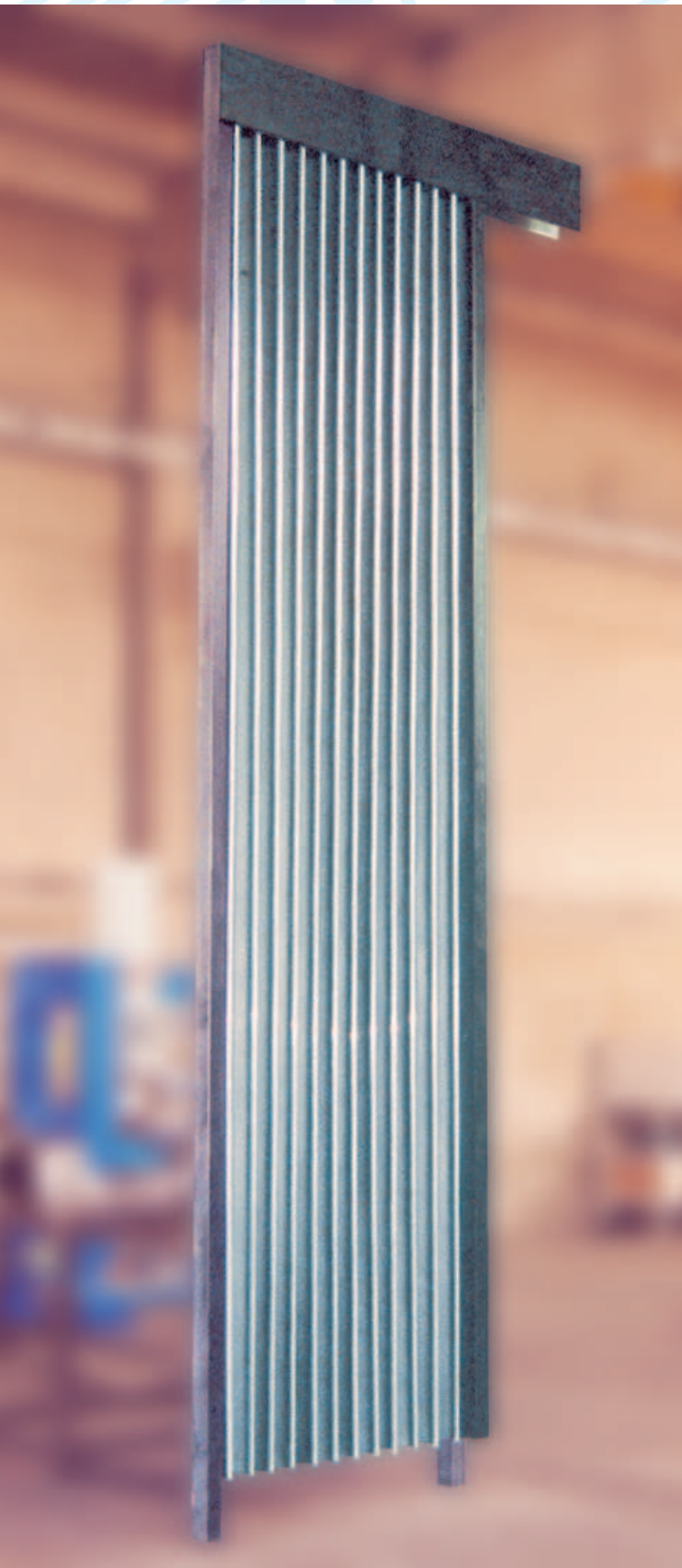

SOFFIETTO PLASTICMETAL® STRONG

PLASTICMETAL® STRONG BELLOWS

PLASTICMETAL® STRONG FALTENBALG

SOUFFLETS PLASTICMETAL® STRONG

STRUTTURA

- 1) Banda (a strisce) di materiale plastico con spessore da 0,8 a 5 mm indeformabile.
- 2) Profilo speciale autobloccante metallico.

Oltre ai vantaggi elencati nel tipo LIGHT questa soluzione presenta ulteriori vantaggi:

- il materiale plastico impiegato resiste alla proiezione di qualsiasi truciolo tagliente e rovente,
- la tenuta ai liquidi è garantita al 100%,
- le sue prestazioni sono superiori alle protezioni telescopiche e ai rotoli avvolgibili (sia tessili che metallici),
- la sua leggerezza e il suo ingombro limitato richiedono una struttura portante nella macchina da proteggere semplice, leggera e poco costosa.

STRUCTURE

- 1) Non deformable plastic stripe in a thickness from 0.8 to 5 mm.
- 2) Special auto fastening steel profile

Further to the advantages listed in the light version this version has even more benefits:

- the used plastic materials withstand to the impact of any hot and sharp debris
- 100% guaranteed water-proof
- Higher performances compared to telescopic way covers and roll-up covers (either textile or steel made)
- Its lightness and reduced space determine a simple load bearing framework, light and cheap.

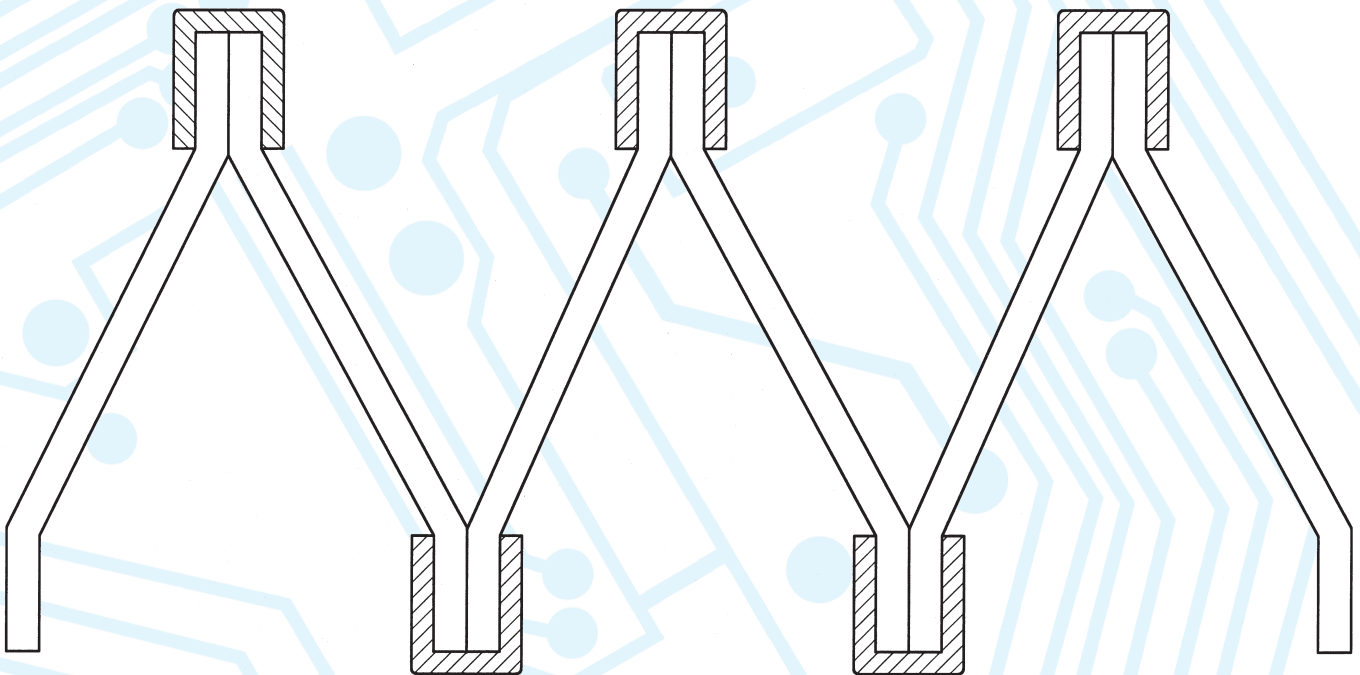

STRUKTUR

- 1) Unverformbares (gestreiftes) Band aus Kunststoff mit Dicke von 0,8 zu 5 mm.
- 2) Metallisches selbstsperrend besonderes Profil.

Neben der Vorteile der Typ "LIGHT" stellt diese Ausführung weitere Vorteile vor:

- Der verwendete Kunststoff ist widerstandsfähig gegen die Projektion jeden schneidenden und glühenden Span,
- die Dichtigkeit hat eine Garantie von 100%,
- die Leistungen sind höherer der Leistungen der Teleskopabdeckungen und der Rollbandabdeckungen (sowohl textilen als auch metallischen),
- Seine Leichtigkeit und seine begrenzte Masse verlangen ein einfaches, billiges und leichtes Tragwerk in der Maschine zu schützen.

CARACTÉRISTIQUES

- 1) Bande en matériel plastique indéformable ayant épaisseur 0,8 à 5 mm.
- 2) Profil spécial autobloquant métallique.

Outre les qualités énumérées pour le type light cette solution présente des ultérieurs avantages:

- matériel plastique employé résistant aux jets des copeaux tranchants et brûlants,
- étanchéité aux liquides garantie à 100%,
- performances supérieures aux protecteurs télescopiques et aux protecteurs à bande (en tissu et en métal).
- légèreté et faible encombrement permettant l'application d'une structure portante simple, légère et économique dans la machine à protéger.

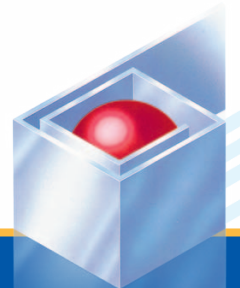

🇮🇹 SOFFIETTO PLASTICMETAL® STRONG

🇬🇧 PLASTICMETAL® STRONG BELLOWS

🇩🇪 PLASTICMETAL® STRONG FALTENBALG

🇮🇹 SOUFFLETS PLASTICMETAL® STRONG

🇮🇹 CAMPO D'IMPIEGO

Questo procedimento elimina la termosaldatura e la facile deformabilità del soffietto termosaldato tradizionale. La costa esterna, essendo protetta dal profilo metallico, non è soggetta ad usura in presenza di proiezioni di trucioli metallici. Nessuna forma o dimensione del soffietto limita la sua costruzione poiché non sussiste il problema della termosaldatura e l'applicazione di pantografi metrici per la sua movimentazione.

Vantaggi:

- Massima leggerezza = Grande velocità, grande accelerazione, assenza di rumore.
- Massima resistenza = Massima protezione contro agenti esterni.
- Grande campo d'impiego = Facilità di progettazione, facilità d'impiego.
- Estetica eccellente = Valore aggiunto all'immagine della macchina finita.

🇬🇧 RANGE OF APPLICATIONS

This process avoids thermal welding and easy deformability of traditional thermic-welded bellows.

The outside crests, being protected by a steel profile, are not subject to wear in presence of metal chips.

No restrictions due to shape or size are bounded to the production as neither thermal welding nor pantograph devices are necessary for their movement.

Advantages:

- Ultra lightness = Great velocity, acceleration, absence of noise.
- Ultra strength = Great protection from exterior agents.
- Wide range of applications = Easy to design, easy to apply.
- Excellent aesthetics = enhancement of machine beauty.

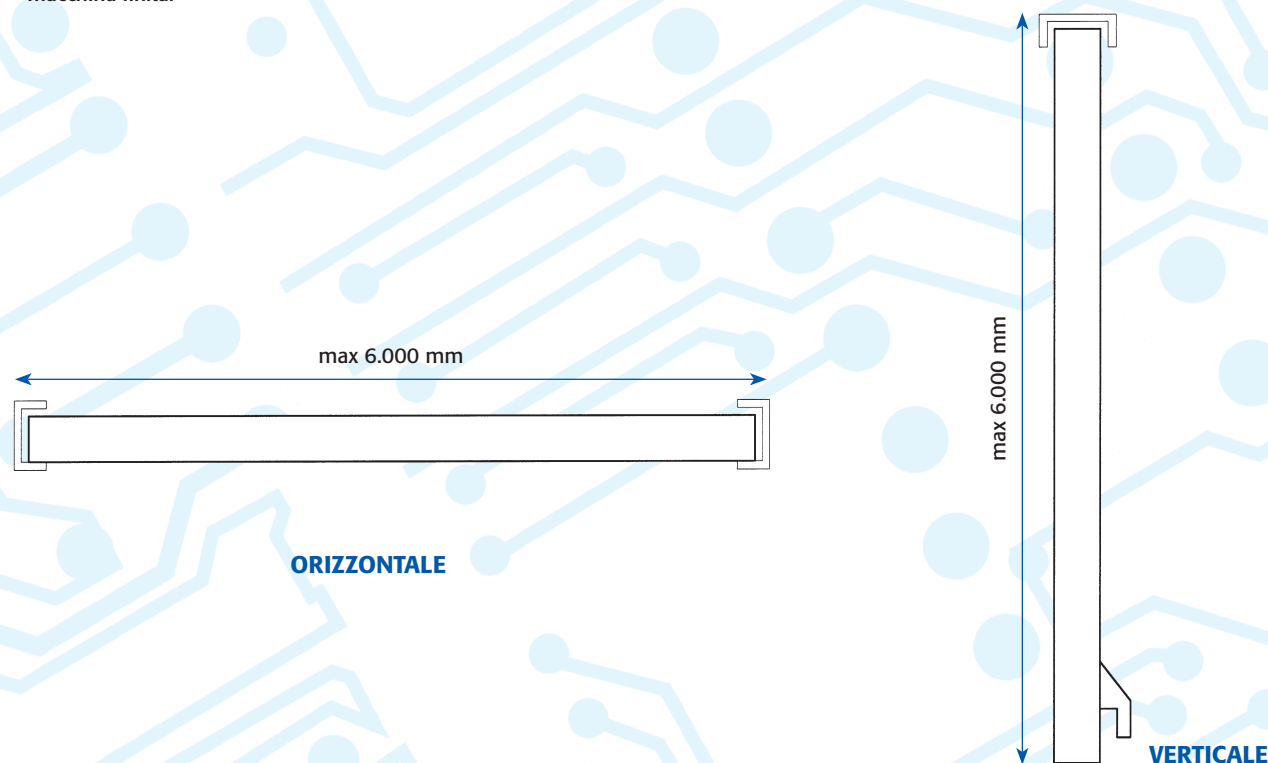

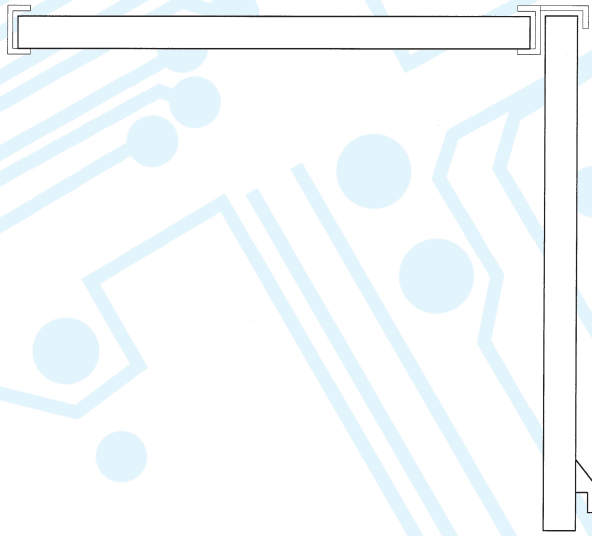

COMBINATO

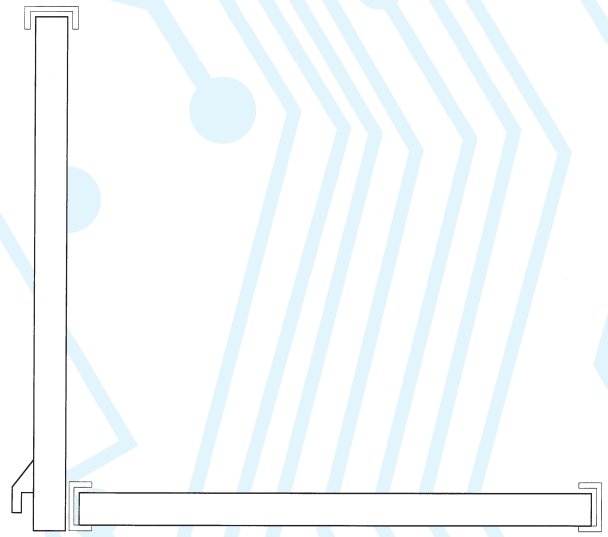

VERWENDUNGSBEREICH

Dieses Verfahren beseitigt die Thermoschweissung und die einfache Umformbarkeit des ueberlieferten thermoschweissten Faltenbalges. Die aussene Rippe abarbeitet sich nicht mit Projektionen von metallische Spaene, weil es von einen metallischen Profil geschuetzt wird.

Keine Form oder Mass des Faltenbalges beschaenkt die Konstruktion, naemlich sind kein Thermoschweissung Problem und keine Verwendung von metrische Scheren fuer seine Bewegung.

Vorteile:

- max. Leichtigkeit = hoehe Geschwindigkeit, hoehe Beschleunigung, Abwesenheit von Gerusch
- max. Bestaendigkeit = maximale Schuetzung gegen aussene Mittel. gresser
- Verwendungsbereich = Bedienbarkeit, Leichtigkeit von Planung aufgezeichnete
- Aesthetik = Mehrwert der Bild der fertigen Maschine

DOMAIN D'UTILISATION

Ce procede permet l'elimination de la thermosoudure et la deformabilite du soufflet thermosoude traditionnel. La nervure exterieure, protegee par un profil metallique, n'est pas exposee a l'usure en presence de copeaux metalliques. Aucun limite de construction a cause de sa forme ou de ses dimensions parce qu'on ne doit recourir ni a la thermosoudure ni a l'application de ciseaux.

Avantages:

- Legerete maximale = Grande vitesse, grande acceleration, absence de bruit.
- Resistance maximale = Protection maximale contre les agents exterieurs.
- Large domaine d'utilisation = Facilite de projection, facilite d'utilisation.
- Esthetique excellente = Valeur adjointe a l'image de la machine.

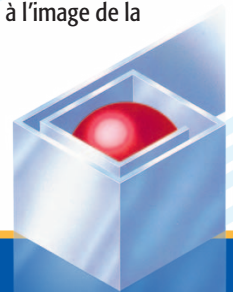

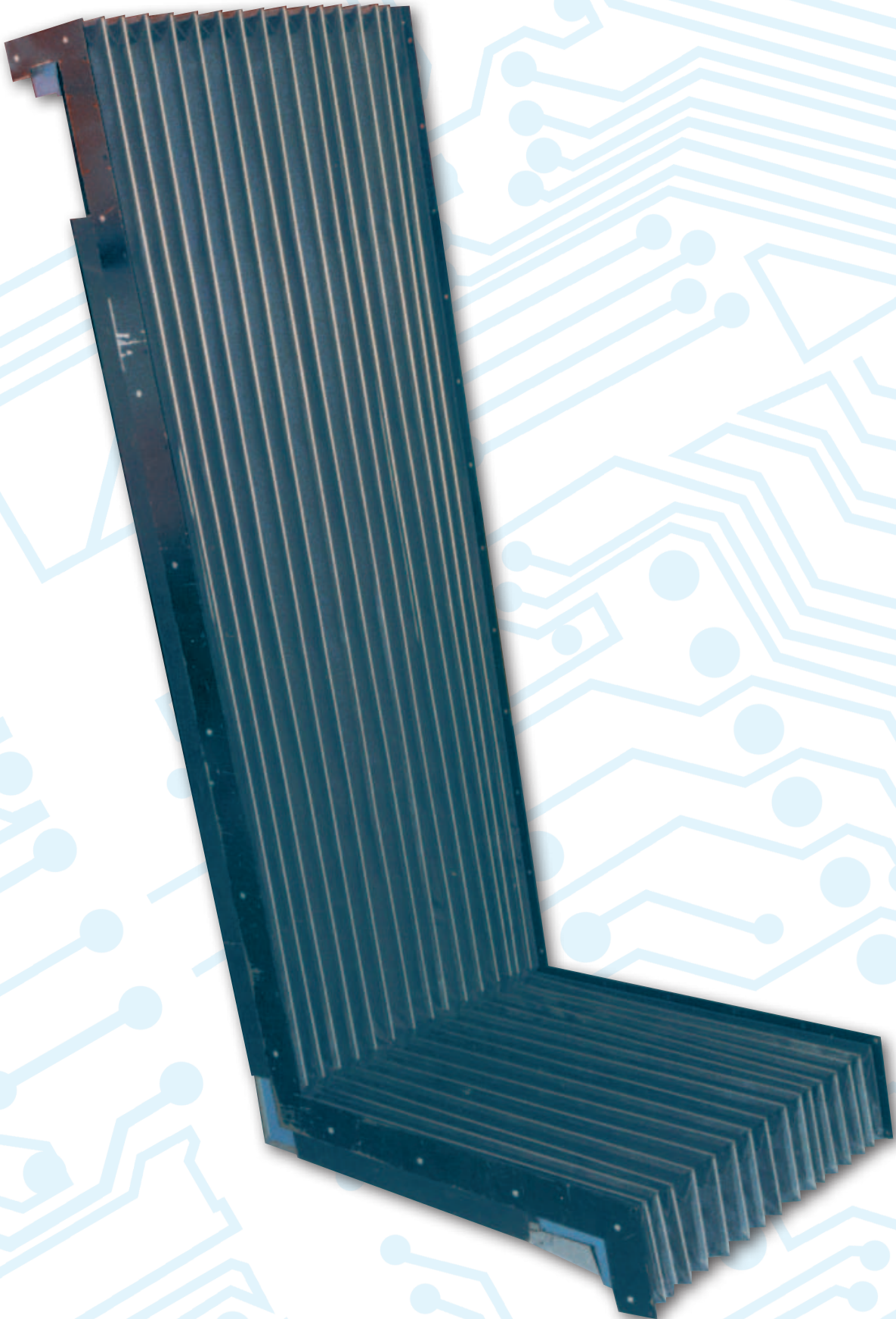

- 🇮🇹 **SOFFIETTO PLASTICMETAL® LIGHT**
- 🇬🇧 **PLASTICMETAL® LIGHT BELLOWS**
- 🇩🇪 **PLASTICMETAL® LIGHT FALTENBALG**
- 🇮🇹 **SOUFFLETS PLASTICMETAL® LIGHT**

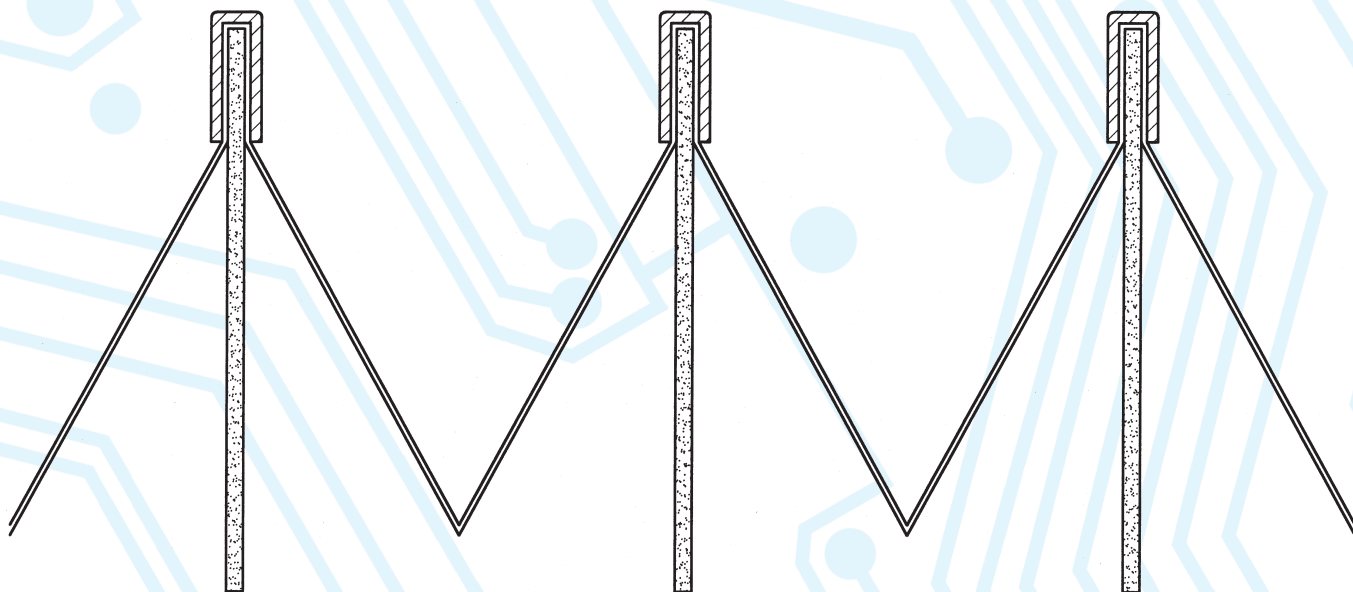

🇮🇹 **STRUTTURA**

- 1) PVC rigido.
- 2) Tessuto ad alta resistenza meccanica e termica (800°), spessore massimo 0,6.
- 3) Profilo di acciaio inox per bloccare il tessuto al telaio in PVC e per irrigidire la struttura del soffietto.

🇩🇪 **STRUKTUR**

- 1) Feste PVC.
- 2) Gewebe mit einer hoehe mechanischen und thermischen (800°) Bestaendigkeit, hoechste dicke = 0,6.
- 3) Profil aus rostfreiem Stahl, um das Gewebe an dem PVC Rahmen zu befestigen und um die Struktur des Faltenbalges verzaerkaeren.

🇬🇧 **STRUCTURE**

- 1) Rigid PVC.
- 2) High thermal (800 C°) and mechanical resistance, max. 0.6 mm. thickness.
- 3) Stainless steel profile for fabric-pvc frame fastening and bellow's body reinforcement.

🇫🇷 **CARACTÉRISTIQUES**

- 1) PVC rigide.
- 2) Tissu a haute resistance mecanique et thermique (800°), épaisseur 0,6 maxi.
- 3) Profil en acier inox pour bloquer le tissu au support en PVC et pour raidir la structure du soufflet.

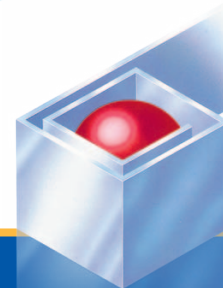

-  **PROGRAMMA DI VENDITA**
-  **SALES PROGRAMME**
-  **LIEFERPROGRAMM**
-  **PROGRAMME DE VENTE**

Protezioni telescopiche
Telescopic covers
Teleskopabdeckungen
Protecteurs telescopiques



Protezioni a nastro
Roll Up covers
Rollo abdeckungen
Protecteurs à bande

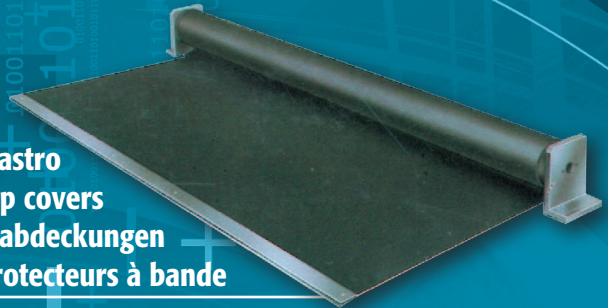

Convogliatori di Trucioli
Chip conveyors
Späneförderer
Convoyeurs à copeaux



Raschiaolio
Way wipers
Abstreifer
Racleurs de glissières

Molle a spirale
Helical metal spring guards
Teleskop-federn
Ressorts helicoidaux



Catene portacavi
Cable carriers
Energieführungsketten
Chaînes porte-cables

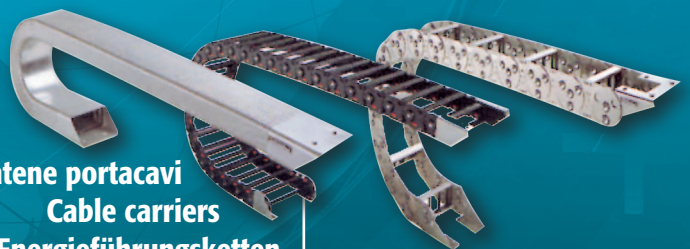

TECNIMETAL

26037 SAN GIOVANNI IN CROCE (CR) | ITALY
 Tel. +39 0375 310082 r.a. Fax +39 0375 91538
 www.tecnimetal.com | e-mail: info@tecnimetal.com