

When you are king ...



www.atorn.de

... your wishes come true.

Wide range of products. Reliable quality. Always available for delivery.

With over 16,000 articles from the areas drilling, milling, turning, grinding and separating tools, as well as measuring equipment, workshop supplies and works equipment, ATORN offers you a wide range of products to meet all of your requirements.

We specialize in particular on the precision and durability of the tools and the best value for money.

ATORN®

Performance requires quality

Workbenches

82030

Workbenches



Type

- Solid beechwood workbench top, oiled on both sides, framework-type glued
- 40 mm workbench thickness
- Base frame / housing permanently welded frame made of square tubular steel (45 x 45 x 2 mm), with levelling system
- Self-supporting with welded-in racks
- Drawers, 4-fold ball-bearing mounted with attached handle (incl. marking strips)

- Load capacity 70 kg, 90% extension
- Drawer internal dimensions W x D 450 x 588 mm
- Swing doors with attached handle (incl. marking strips), self-closing
- Compartment internal dimensions: W x D 560 x 620 mm
- Centralised locking, each family lock with 2 keys
- Standard finish, housing RAL 7035 light grey, fronts RAL 5012 light blue
- Environmentally friendly powder-coating



82030 203+303



82030 204+304



82030 208+308



82030 205+305



82030 201+301



82030 212+312



82030 202+302



82030 213+313



82030 207+307



82030 211+311



82030 210+310



82030 206+306

Continuation

Facility Equipment

Continuation ▶

82030 201-213

Type

- With fixed working height, 840 mm

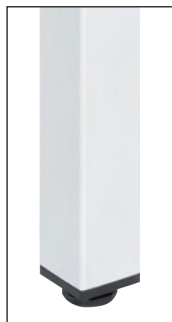

fixed

82030 301-313

Type

- With adjustable working height, 840 - 1,040 mm



adjustable

82030 401-414

Type

- With drive system that can be lowered
 - The workbench is brought into the moving or standing position by simply folding over a lever
 - Total load capacity of the workbench:
 stationary, 800 kg
 moving with the castors lowered, 400 kg



with drive system

Worktop plate L x D mm	Drawers Number x Height mm	Doors Number x Height mm	Shelves Amount	fixed		adjustable		with drive system	
				82030	...	82030	...	82030	...
1500 x 700	1x180	1x360	-	F #	203	F #	303		
1500 x 700	1x180	1x360	1	F #	208 NEW	F #	308 NEW	F #	408 NEW
1500 x 700	2x180	2x360	-	F #	201	F #	301	F #	401 NEW
1500 x 700	3x180	1x540	1	F #	202	F #	302	F #	402 NEW
1500 x 700	6x180	-	-	F #	207 NEW	F #	307 NEW	F #	407 NEW
1500 x 700	1x60, 2x90, 1x120, 1x180	-	-	F #	210	F #	310		
2000 x 700	2x180	2x360	1	F #	204	F #	304	F #	404 NEW
2000 x 700	3x180	1x540	1	F #	205	F #	305	F #	405 NEW
2000 x 700	3x180	2x540	2	F #	212 NEW	F #	312 NEW	F #	413 NEW
2000 x 700	5x180	2x360	2	F #	213 NEW	F #	313 NEW	F #	414 NEW
2000 x 700	6x180	-	1	F #	211 NEW	F #	311 NEW	F #	411 NEW
2000 x 700	1x60, 2x90, 1x120, 1x180	1x540	1	F #	206	F #	306	F #	406 NEW

82035 - 82037

Drawer fitting assortments for workbenches cat.-no. 82030



82035

Type

- 1 longitudinal divider
 - 4 crosswise dividers

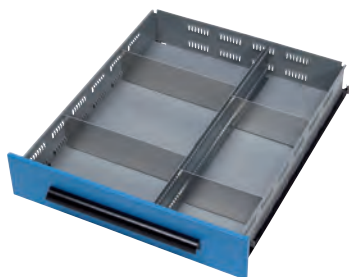

82036

Type

- 2 longitudinal dividers
 - 9 crosswise dividers

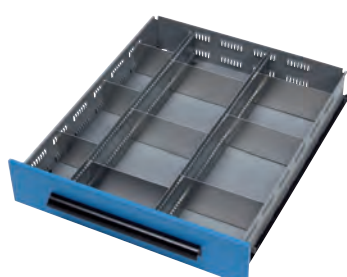

82037

Type

- 3 longitudinal dividers
 - 16 crosswise dividers



for drawer height mm	Drawer internal dimensions W x D mm	82035	...	82036	...	82037	...
60	480 x 588	#	201	#	201	#	201
90	480 x 588	#	204	#	204	#	204
120 / 150	480 x 588	#	202	#	202	#	202
180-270	480 x 588	#	203	#	203	#	203

82038

Back walls for workbenches cat.-no. 82030

Type

- Material MDF

for workbench length mm	Height mm	82038	...
1500	100	#	201
2000	100	#	202



Workbenches

82075

Workbenches 1500 mm Serie V



Type

- Max. load capacity for each drawer, 100 kg
- Max. load capacity of the workbench, 1,500 kg
- Drawers with 100% extension
- Door opening angle, 180°
- Single drawer lock
- Centralised locking
- Drawer internal dimensions 500 x 540 mm
- Square foot frame 45 x 45 x 2 mm
- Drawers with perforated base, through plates
- Levelling compensation 1 x 20 mm
- Workbench completely mounted



BMP ANKE Solid beechwood worktop

Thanks to the unique production method:

- Extremely long service life
- Robust and resistant
- Extremely durable
- Can be resanded many times
- Oiled surface
- Glued and pin fixed on the longitudinal side

- Marking strip with high-quality aluminium handle
- Housing colour RAL 7035 light grey,
- Front colour RAL 5012 light blue

Note:

Front colour RAL 6011 reseda green without surcharge (not in stock).
Further colours available on request subject to surcharge.

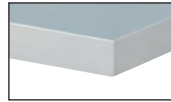

UBP universal worktop

- With ABS edge
- Wear resistant and anti-static
- Short-term resistance against light acids and alkalines as well as the effect of heat up to approx. 250°C
- Long-term resistance against grease and oils

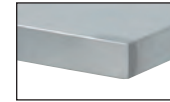

ZBP galvanised sheet steel worktop

- With 1.5 mm galvanised sheet steel covering
- Crimped on all sides around the edges
- Welded and ground corners
- Easy care, ideal for working with oils
- Hot-dip galvanised, long-term corrosion resistance

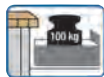

Worktop L x D mm	Height up to upper edge plate mm	Plate	Plate thickness mm	Weight approx. kg	82075	...
1500 x 700	850	BMP	50	125	F #	105
1500 x 700	850	UBP	50	125	F #	106
1500 x 700	850	ZBP	50	125	F #	107
1500 x 700	900	BMP	50	126	F #	108
1500 x 700	900	UBP	50	126	F #	109
1500 x 700	900	ZBP	50	126	F #	110



Worktop L x D mm	Height up to upper edge plate mm	Plate	Plate thickness mm	Weight approx. kg	82075	...
1500 x 700	850	BMP	50	132	F #	140
1500 x 700	850	UBP	50	132	F #	141
1500 x 700	850	ZBP	50	132	F #	142
1500 x 700	900	BMP	50	133	F #	143
1500 x 700	900	UBP	50	133	F #	144
1500 x 700	900	ZBP	50	133	F #	145



Worktop L x D mm	Height up to upper edge plate mm	Plate	Plate thickness mm	Weight approx. kg	82075	...
1500 x 700	850	BMP	50	145	F #	160
1500 x 700	850	UBP	50	145	F #	161
1500 x 700	850	ZBP	50	145	F #	162
1500 x 700	900	BMP	50	146	F #	163
1500 x 700	900	UBP	50	146	F #	164
1500 x 700	900	ZBP	50	146	F #	165



Worktop L x D mm	Height up to upper edge plate mm	Plate	Plate thickness mm	Weight approx. kg	82075	...
1500 x 700	850	BMP	50	124	F #	180
1500 x 700	850	UBP	50	124	F #	181
1500 x 700	850	ZBP	50	124	F #	182
1500 x 700	900	BMP	50	125	F #	183
1500 x 700	900	UBP	50	125	F #	184
1500 x 700	900	ZBP	50	125	F #	185



Worktop L x D mm	Height up to upper edge plate mm	Plate	Plate thickness mm	Weight approx. kg	82075	...
1500 x 700	850	BMP	50	115	F #	200
1500 x 700	850	UBP	50	115	F #	201
1500 x 700	850	ZBP	50	115	F #	202
1500 x 700	900	BMP	50	116	F #	203
1500 x 700	900	UBP	50	116	F #	204
1500 x 700	900	ZBP	50	116	F #	205

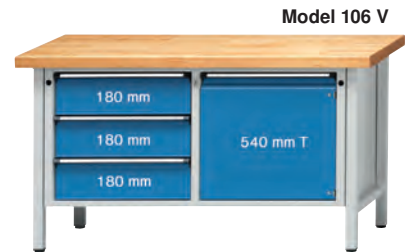

Model 106 V



Model 205 V

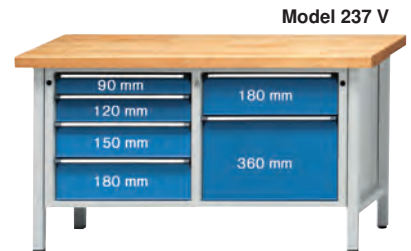

Model 237 V

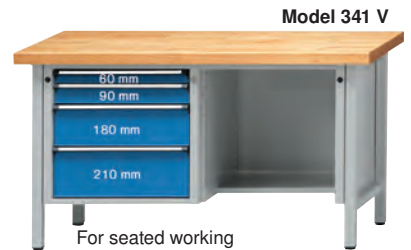

Model 341 V

For seated working

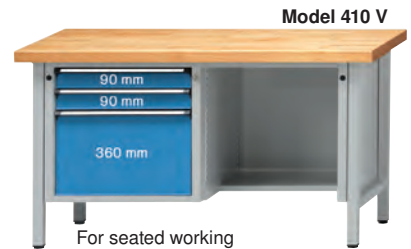

Model 410 V

For seated working



Facility Equipment

Worktop L x D mm	Height up to upper edge plate mm	Plate	Plate thickness mm	Weight approx. kg	82075	...
2000 x 700	850	BMP	50	177	F #	220
2000 x 700	850	UBP	50	177	F #	221
2000 x 700	850	ZBP	50	177	F #	222
2000 x 700	900	BMP	50	178	F #	223
2000 x 700	900	UBP	50	178	F #	224
2000 x 700	900	ZBP	50	178	F #	225

Worktop L x D mm	Height up to upper edge plate mm	Plate	Plate thickness mm	Weight approx. kg	82075	...
2000 x 700	850	BMP	50	157	F #	240
2000 x 700	850	UBP	50	157	F #	241
2000 x 700	850	ZBP	50	157	F #	242
2000 x 700	900	BMP	50	158	F #	243
2000 x 700	900	UBP	50	158	F #	244
2000 x 700	900	ZBP	50	158	F #	245

Worktop L x D mm	Height up to upper edge plate mm	Plate	Plate thickness mm	Weight approx. kg	82075	...
2000 x 700	850	BMP	50	180	F #	280
2000 x 700	850	UBP	50	180	F #	281
2000 x 700	850	ZBP	50	180	F #	282
2000 x 700	900	BMP	50	181	F #	283
2000 x 700	900	UBP	50	181	F #	284
2000 x 700	900	ZBP	50	181	F #	285

Worktop L x D mm	Height up to upper edge plate mm	Plate	Plate thickness mm	Weight approx. kg	82075	...
2000 x 700	850	BMP	50	159	F #	320
2000 x 700	850	UBP	50	159	F #	321
2000 x 700	850	ZBP	50	159	F #	322
2000 x 700	900	BMP	50	160	F #	323
2000 x 700	900	UBP	50	160	F #	324
2000 x 700	900	ZBP	50	160	F #	325

Drawer divider material	Front height mm	82075	...
1/2 division	for 60	#	900
1/2 division	for 90 + 120 + 150	#	901
1/2 division	for 180 + 360	#	903
1/3 division	for 60	#	904
1/3 division	for 90 + 120 + 150	#	905
1/3 division	for 180 + 360	#	907
1/4 division	for 60	#	908
1/4 division	for 90 + 120 + 150	#	909
1/4 division	for 180 + 360	#	911
1/2 - 1/4 division	for 60	#	912
1/2 - 1/4 division	for 90 + 120 + 150	#	913
1/2 - 1/4 division	for 180 + 360	#	915
Anti-slip mat	-	#	923
Drawer divider made from plastic	from 90	#	924
Trough divider, 5 compartments, 10 dividers	from 90	#	925
Trough divider, 6 compartments, 10 dividers	from 90	#	926

Accessories	Length mm	Height mm	82075	...
Roller strip	1500	90	#	916
Roller strip	2000	90	#	917
Document compartment	-	-	#	918
Shelf, height adjustable	-	-	#	919
Pull-out shelf, height adjustable	-	-	#	920
Centralised locking, electronic	-	-	#	921
System panel for foot frames	-	-	#	922

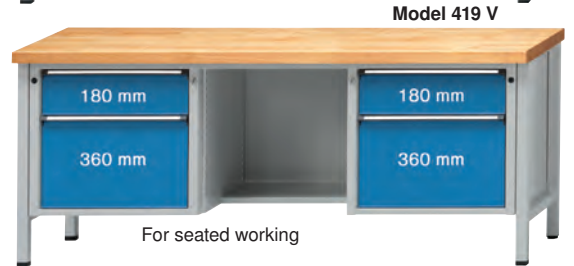
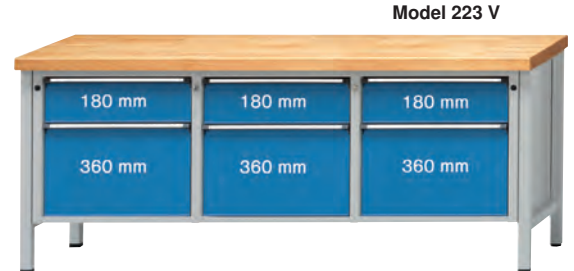
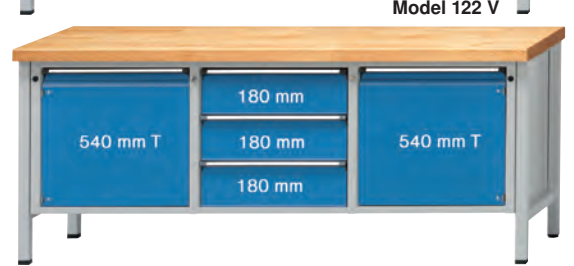
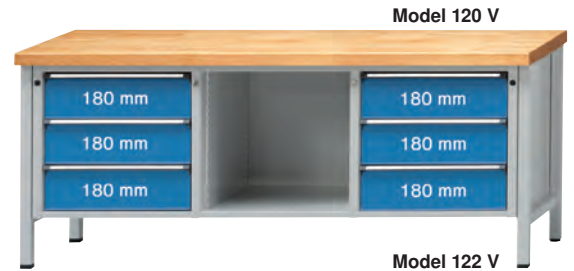

For seated working

82075 900-903 82075 904-907 82075 908-911



82075 912-915 82075 923 82075 924



82075 925 82075 926



82075 916-917 82075 918 82075 919



82075 920 82075 921 82075 922



Facility Equipment

Workbenches

82076

Workbenches 2800 mm Serie V



Type

- Max. load capacity for each drawer, 100 kg
- Max. load capacity of the workbench, 1,500 kg
- Drawers with 100% extension
- Door opening angle, 180°
- Single drawer lock

- Central lock
- Drawer inside dimension 500 x 540 mm
- Square foot frame 45 x 45 x 2 mm
- Drawers with perforated base, through plates
- Level compensation 6 x 20 mm
- Workbench mounted completely
- Marking strip with high-quality aluminium handle

- Housing colour RAL 7035 light grey
- Front colour RAL 5012 light blue

Note:

Front colour RAL 6011 reseda green without surcharge (not in stock). Other colours on request subject to surcharge.



Worktop L x D mm	Height up to upper edge Plate mm	Plate	Plate thickness mm	Weight approx. kg	82076	...
2800 x 700	850	BMP	50	238	F #	100
2800 x 700	850	UBP	50	238	F #	101
2800 x 700	850	ZBP	50	238	F #	102
2800 x 700	900	BMP	50	239	F #	103
2800 x 700	900	UBP	50	239	F #	104
2800 x 700	900	ZBP	50	239	F #	105



Worktop L x D mm	Height up to upper edge Plate mm	Plate	Plate thickness mm	Weight approx. kg	82076	...
2800 x 700	850	BMP	50	249	F #	120
2800 x 700	850	UBP	50	249	F #	121
2800 x 700	850	ZBP	50	249	F #	122
2800 x 700	900	BMP	50	250	F #	123
2800 x 700	900	UBP	50	250	F #	124
2800 x 700	900	ZBP	50	250	F #	125



Worktop L x D mm	Height up to upper edge Plate mm	Plate	Plate thickness mm	Weight approx. kg	82076	...
2800 x 700	850	BMP	50	251	F #	140
2800 x 700	850	UBP	50	251	F #	141
2800 x 700	850	ZBP	50	251	F #	142
2800 x 700	900	BMP	50	252	F #	143
2800 x 700	900	UBP	50	252	F #	144
2800 x 700	900	ZBP	50	252	F #	145



Accessories	Length mm	Height mm	82075	...
Roller strip	2800	90	#	927
Document compartment	-	-	#	918
Shelf, height adjustable	-	-	#	919
Pull-out shelf, height adjustable	-	-	#	920
Centralised locking, electronic	-	-	#	921
System panel for foot frames	-	-	#	922

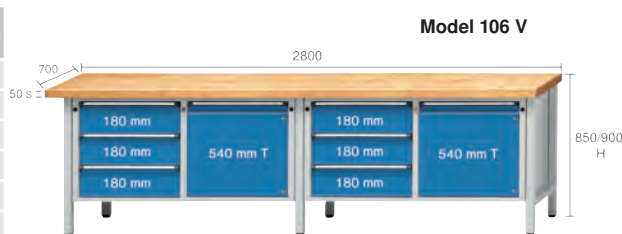

Model 106 V

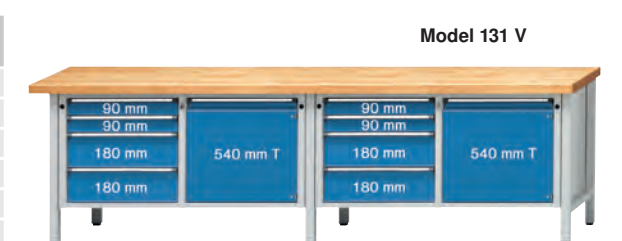

Model 131 V

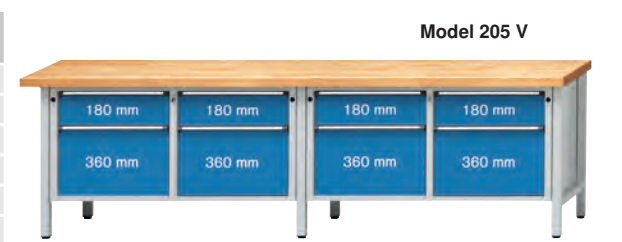

Model 205 V

82075 927



82075 920

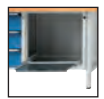

82075 918



82075 921



82075 919



82075 922



Drawer divider material matching for cat. no. 82076 workbenches and cat. no. 82078 combined workbenches

Drawer divider material	Front height mm	82075	...
1/2 division	for 60	#	900
1/2 division	for 90 + 120 + 150	#	901
1/2 division	for 180 + 360	#	903
1/3 division	for 60	#	904
1/3 division	for 90 + 120 + 150	#	905
1/3 division	for 180 + 360	#	907
1/4 division	for 60	#	908
1/4 division	for 90 + 120 + 150	#	909
1/4 division	for 180 + 360	#	911
1/2 - 1/4 division	for 60	#	912
1/2 - 1/4 division	for 90 + 120 + 150	#	913
1/2 - 1/4 division	for 180 + 360	#	915
Anti-slip mat	-	#	923
Drawer divider made from plastic	from 90	#	924
Trough divider, 5 compartments, 10 dividers	from 90	#	925
Trough divider, 6 compartments, 10 dividers	from 90	#	926

82075 900-903



82075 904-907



82075 908-911



82075 912-915



82075 923



82075 924



82075 925



82075 926



Facility Equipment



Type

- Max. load capacity for each drawer, 100 kg
- Max. load capacity of the workbench, 800 kg
- Drawers with 100% extension
- Door opening angle, 180°
- Single drawer lock
- Central lock
- Drawer inside dimension 500 x 540 mm
- Square foot frame 45 x 45 x 2 mm
- Drawers with perforated base and through plates

- Levelling compensation 1 x 20 mm
- Workbench mounted completely
- Marking strip with high-quality aluminium handle
- Housing colour RAL 7035 light grey
- Front colour RAL 5012 light blue

Note:

Front colour RAL 6011 reseda green without surcharge (not in stock). Further colours available on request subject to surcharge.

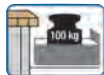
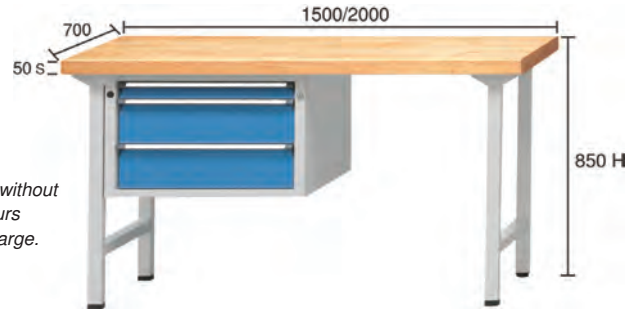

Worktop L x D mm	Height up to upper edge plate mm	Plate	Plate thickness mm	Weight approx. kg	82078	...
1500 x 700	850	BMP	50	94	F #	100
1500 x 700	850	UBP	50	94	F #	101
1500 x 700	850	ZBP	50	94	F #	102
2000 x 700	850	BMP	50	106	F #	103
2000 x 700	850	UBP	50	106	F #	104
2000 x 700	850	ZBP	50	106	F #	105

Worktop L x D mm	Height up to upper edge plate mm	Plate	Plate thickness mm	Weight approx. kg	82078	...
1500 x 700	850	BMP	50	98	F #	120
1500 x 700	850	UBP	50	98	F #	121
1500 x 700	850	ZBP	50	98	F #	122
2000 x 700	850	BMP	50	111	F #	123
2000 x 700	850	UBP	50	111	F #	124
2000 x 700	850	ZBP	50	111	F #	125

Worktop L x D mm	Height up to upper edge plate mm	Plate	Plate thickness mm	Weight approx. kg	82078	...
1500 x 700	850	BMP	50	103	F #	160
1500 x 700	850	UBP	50	103	F #	161
1500 x 700	850	ZBP	50	103	F #	162
2000 x 700	850	BMP	50	128	F #	163
2000 x 700	850	UBP	50	128	F #	164
2000 x 700	850	ZBP	50	128	F #	165

Accessories	Length mm	Height mm	82075	...
Roller strip	1500	90	#	916
Roller strip	2000	90	#	917
Document compartment	-	-	#	918
Shelf, height adjustable	-	-	#	919
Pull-out shelf, height adjustable	-	-	#	920
Centralised locking, electronic	-	-	#	921

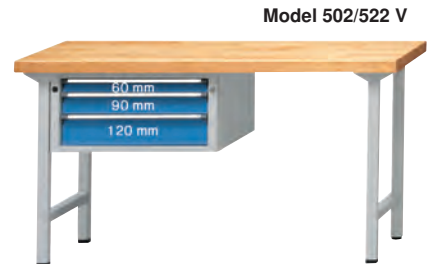

Model 502/522 V

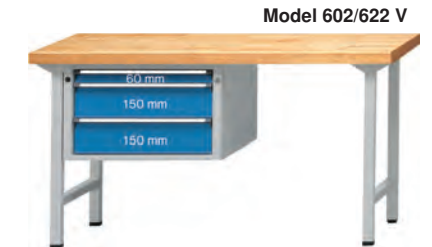

Model 602/622 V

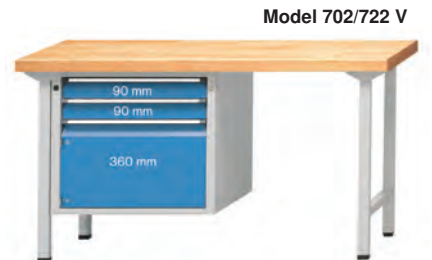

Model 702/722 V

82075 916-917



82075 918



82075 919



82075 920



82075 921



Facility Equipment

Worktops matching for cat. no. 82076 workbenches and cat. no. 82078 combined workbenches



BMP ANKE solid beechwood worktop

Thanks to the unique production method:

- Extremely long service life
- Robust and resistant
- Extremely durable
- Can be resanded many times
- Oiled surface
- Glued and pin fixed on the longitudinal side

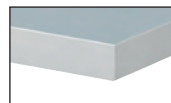

UBP universal worktop

- With ABS edge
- Wear resistant and anti-static
- Short-term resistance against light acids and alkalines as well as the effect of heat up to approx. 250°C
- Long-term resistance against grease and oils

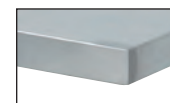

ZBP galvanised sheet steel worktop

- With 1.5 mm galvanised sheet steel covering
- Crimped on all sides around the edges
- Welded and ground corners
- Easy care, ideal for working with oils
- Hot-dip galvanised, long-term corrosion resistance



Workbenches

82080

Workbenches 1500 mm Serie VX



Type

- Max. load capacity for each drawer, 100 kg
- Max. load capacity of the workbench 1500 kg
- Drawers with 100% extension
- Single drawer lock
- Central lock
- Drawer internal dimension 1200 x 600 mm
- Square foot frame 45 x 45 x 2 mm
- Drawers with perforated base, through plates

- Levelling compensation 1 x 20 mm
- Workbench mounted completely
- Marking strips with high-quality aluminium handle
- Housing colour RAL 7035 light grey
- Front colour RAL 5012 light blue

Note:

Front colour RAL 6011 reseda green without surcharge (not in stock).
Further colours available on request subject to surcharge.



XXL drawers

0.72 sqm storage area per drawer



BMP ANKE solid beechwood worktop

Thanks to the unique production method:

- Extremely long service life
- Robust and resistant
- Extremely durable
- Can be resanded many times
- Oiled surface
- Glued and pin fixed on the longitudinal side

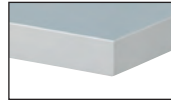

UBP universal worktop

- With ABS edge
- Wear resistant and anti-static
- Short-term resistance against light acids and alkalines as well as the effect of heat up to approx. 250 °C
- Long-term resistance against grease and oils

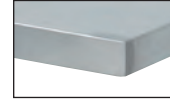

ZBP galvanised sheet steel worktop

- With 1.5 mm galvanised sheet steel covering
- Crimped on all sides around the edges
- Corners welded and ground
- Easy care, ideal for working with oils
- Hot-dip galvanised, long-term corrosion resistance

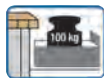

Worktop L x D mm	Height up to upper edge plate mm	Plate	Plate thickness mm	Weight ca. kg	82080	...
1500 x 800	850	BMP	50	148	F #	100
1500 x 800	850	UBP	50	148	F #	101
1500 x 800	850	ZBP	50	148	F #	102
1500 x 800	900	BMP	50	149	F #	103
1500 x 800	900	UBP	50	149	F #	104
1500 x 800	900	ZBP	50	149	F #	105



Worktop L x D mm	Height up to upper edge plate mm	Plate	Plate thickness mm	Weight ca. kg	82080	...
1500 x 800	850	BMP	50	148	F #	120
1500 x 800	850	UBP	50	154	F #	121
1500 x 800	850	ZBP	50	154	F #	122
1500 x 800	900	BMP	50	155	F #	123
1500 x 800	900	UBP	50	155	F #	124
1500 x 800	900	ZBP	50	155	F #	125

Drawer divider material	Front height mm	82075	...
1/4 division	for 60	#	928
1/4 division	for 120	#	929
1/4 division	for 180 + 360	#	931
Anti-slip matting	-	#	932

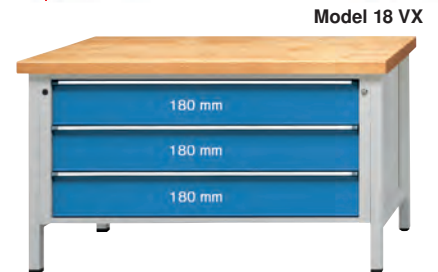
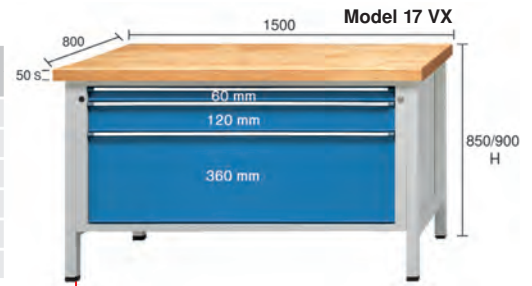

82075 928-931

82075 932



82075 916

82075 921

82075 954



Accessories	Length mm	Height mm	82075	...
Roller strip	1500	90	#	916
Centralised locking, electronic	-	-	#	921
System panel for foot frames	-	-	#	954



Type

- Max. load capacity for each drawer, 100 kg
- Max. load capacity of the workbench 4200 kg
- Drawers with 100% extension
- Door opening angle, 180°
- Single drawer lock
- Central lock
- Drawer internal dimension 500 x 540 mm

- Square foot frame 80 x 80 x 3 mm
- Drawers with perforated base, through plates
- Fishplate for screwing onto the base
- Workbench mounted completely
- Marking strips with high-quality aluminium handle
- Husing colour RAL 7035 light grey
- Front colour RAL 5012 light blue

Note:

Front colour RAL 6011 reseda green without surcharge (not in stock). Further colours available on request subject to surcharge.



BMP ANKE solid beechwood worktop

Thanks to the unique production method:

- Extremely long service life
- Robust and resistant
- Extremely durable
- Can be resanded many times
- Oiled surface
- Glued and pin fixed on the longitudinal side

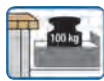

Worktop L x D mm	Height up to upper edge plate mm	Plate	Plate thickness mm	Weight ca. kg	82084	...
2250 x 800	900	BMP	100	282	F #	200

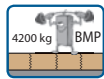

Worktop L x D mm	Height up to upper edge plate mm	Plate	Plate thickness mm	Weight ca. kg	82084	...
1500 x 800	900	BMP	100	196	F #	201



Worktables						
Worktop L x D mm	Height up to upper edge plate mm	Plate	Plate thickness mm	Weight ca. kg	82084	...
1500 x 800	900	BMP	100	125	F #	301



Drawer divider material	Front height mm	82075	...
1/2 division	for 180	#	903
1/3 division	for 180	#	907
1/4 division	for 180	#	911
1/2 - 1/4 division	for 180	#	915
Anti-slip matting	-	#	923
Drawer divider made from plastic	from 90	#	924
Trough divider, 5 compartments, 10 dividers	from 90	#	925
Trough divider, 6 compartments, 10 dividers	from 90	#	926



Accessories			82075	...
Document compartment	#	918		
Shelf, height adjustable	#	919		
Pull-out shelf, height adjustable	#	920		
Centralised locking, electronic	#	921		
System panel for foot frames	#	922		

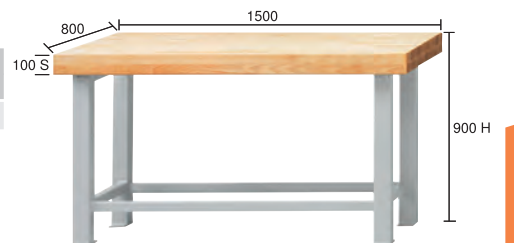
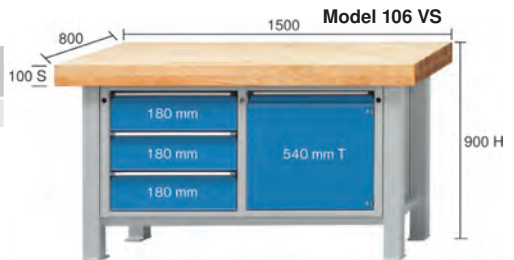
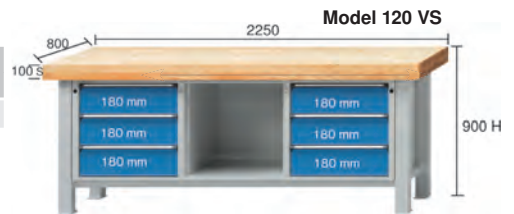

Facility Equipment



82309

Power strips



Type
 - Wired using a plug system
 - Colour RAL 7035, light grey

82309 101 + 201
Type
 Equipped with:
 - 2 x double power socket 230 V/50 Hz,
 10/16A, 2-pin



82309 101 + 201

82309 102 + 202
Type
 Equipped with:
 - 1 x double power socket 230 V/50 Hz,
 10/16A, 2-pin
 - 1 x CEE socket 400 V/50 Hz, 16 A, 5-pin



82309 102 + 202

82309 103 + 203
Type
 Equipped with:
 - 1 x double power socket 230 V/50 Hz,
 10/16A, 2-pin
 - 2 x quick-action coupling for compressed air



82309 103 + 203

Dimensions W x D x H mm	Equipped	82309	...
1500 x 90 x 170	4 x 230 V	#	101
1500 x 90 x 170	2 x 230 V / 1 x CEE	#	102
1500 x 90 x 170	2 x 230 V / 2 x DL	#	103

Dimensions W x D x H mm	Equipped	82309	...
2000 x 90 x 170	4 x 230 V	#	201
2000 x 90 x 170	2 x 230 V / 1 x CEE	#	202
2000 x 90 x 170	2 x 230 V / 2 x DL	#	203

Info Fittings attachment block

For the installation of any fittings manufactured from quality fine sheet steel, lacquered.

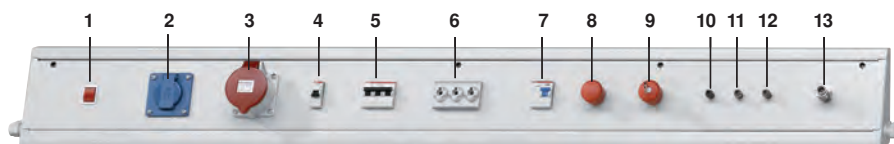

- | | |
|------------------------------------------------------|--------------------------------------------------------|
| 1 illuminated on/off-switch, 2-pole, | 7 fault current safety switch, 25 A, 30 mA, 230/380 V, |
| 2 power socket with lid, 2-pole + E 10/16 A 230 V, | 8 emergency button without key, |
| 3 CEE power socket with lid, 5-pole 16 A 380 V, | 9 emergency button with key, |
| 4 overload release, 1-pole L 16 A, | 10 pole clamp, 4 mm, red, |
| 5 overload release, 3-pole G 16 A, | 11 pole clamp, 4 mm, black, |
| 6 screw safety element Neozed, 3-pole, without fuse, | 12 earthing bush, 4 mm, yellow-green, |
| | 13 quick-action coupling for compressed air. |

The power supply assemblies are supplied unwired. Available lengths 750 mm/1250 mm/1500 mm/2000 mm/2800 mm and 4000 mm. Please contact us for price information. Please state position and kind of fittings when placing the order.

82250

Working tables



Type
BMP - ANKE solid beechwood worktop
Thanks to the unique production method:
 - Extremely long service life
 - Robust and resistant
 - Extremely durable
 - Van be resanded many times
 - Oiled surface
 - Glued and pin fixed on the longitudinal side

- Foot frame made of square tubular steel 45/45/2 mm
 - RAL 7035
 - All feet with wear-resistant ANKE special foot caps
 - One height adjustable as level compensation (20 mm)
 - Supplied fully assembled!



82250 101-102



82250 103

Worktop L x D mm	Height up to upper edge plate mm	Plate	Plate thickness mm	Number of foot frames	82250	...
1500 x 700	840	BMP	40	2	F #	101
2000 x 700	840	BMP	40	2	F #	102
2800 x 700	840	BMP	40	3	F #	103

82131

Mobile assembly workbench Serie V with vice + folding unit



Type

BMP - Original ANKE solid beechwood worktop

- 50 mm thick
- Glued and pin fixed on the longitudinal side
- Extremely long service life
- Robust and tough
- Extremely durable
- Can be resanded many times
- Surface oiled

Standard equipment

- Workbench load capacity max. 1,500 kg
- Drawers with 100% extension
- Drawer load capacity max. 100 kg
- Drawer stop
- Internal drawer dimensions W 500 x T 540 mm
- Perforated base and through plates
- Handle profile with marking bar
- Door opening angle, 180°
- Central locking
- Levelling compensation 1 x 20 mm
- Foot made of square tubular steel 45 x 45 x 2 mm
- Castor diameter 125 mm
- Workbench mounted completely
- Finish RAL 7035/5012

Scope of supply:

- Workbench
- Vice (jaw width 100 mm)
- Folding lift (can be rotated by 360°, height adjustable)

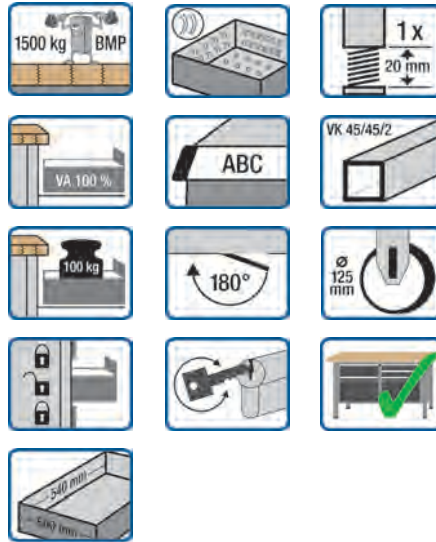

Model	Number of drawers x Front height mm	Plate type	Plate size mm	Working height mm	82131	...
701V	1x180 / 1x360	BMP	1270 x 700 x 50	850	F #	102
706V	3x180	BMP	1270 x 700 x 50	850	F #	103

82132

Attachment for assembly workbenches Serie V



Use

For assembly workbenches Serie V, cat.-no. 82131.



Body version	Perforated plate W x H mm	Power strips equipped	Number of holding rails	82132	...
A	1165 x 550	-	-	F #	101
B	1165 x 550	2 x earthed outlets 230 V / 1 x CEE 400 V	-	F #	102
D	1165 x 550	-	2	F #	103
E	1165 x 550	2 x earthed outlets 230 V / 1 x CEE 400 V	2	F #	104

Info

Castors for workbenches

Available for all ANKE series V, VH and BL workbenches up to a length of 2,000 mm with a working height of 840 mm or 850 mm.

The workbench is brought into the moving or standing position by simply folding over a lever. Rollers Ø 100 mm, load capacity of the workbench on the rollers including own weight, max. 450 kg.

When the chassis is extracted, the drive system offer the best maneuverability thanks to the steering castors and when standing on the 4 feet, an optimum stability (1,500 kg with load distributed equally over the surface).

Note:

Delivery of the drive system only ex-factory in combination with the workbench. Subsequent installation is not possible.



82255

Height compensation



Type

Made of shock-proof and wear-resistant material, especially for uneven floors.

Use

For all workbenches and worktables with square tubular steel foot frame 45/45/2 mm.



82255

Adjustment range
mm

15

82255

...

#

101

82290 - 82295

Hexagonal Workbenches for Work Groups



Type

1. Worktop

40 or 50 mm thick, warp-proof made of beechwood Multiplex, waterproof glued, or solid beechwood. Supplied in 2 parts, in the middle at the connection with groove and spring and Lamello screw fitting.

2. Tool cabinet

800 x 572 x 600 mm, made of stable sheet steel, centralised locking, drawers ball-bearing mounted, 60 kg capacity, 85% extension. Drawer stop, inside with slotted strips and perforated base for individual fitting. Useful space and fitting material see cat.-no. 82345. Space between the cabinets is covered by sheet metals.

Overall height of the workbench, without fittings attachment block, 840 mm at 40 mm workbench top and 850 mm at 50 mm workbench top. Internal drawer dimensions W x D 437 x 513 mm.

Standard finish:

Housing RAL 7035 light grey, drawers RAL 5012 light blue, powder-coated. Not assembled.



Fittings attachment block available on request

This workbench configuration offers the possibility to create workplaces in training centres effectively.

One workbench covers 6 workplaces.

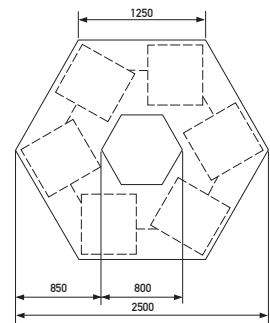

82290

Type

6 tool cabinets with 6 drawers each,

front height 1 x 60, 3 x 90 1 x 180 mm and 1 x 210 mm, per workplace.

82295

Type

6 tool cabinets with 2 drawers each,

front height 1 x 60, 1 x 90 mm and 1 door 570 mm, per workplace.

Note:

Other combinations, tool cabinets with 100% extension, octagonal designs, and fittings attachment blocks available on request. Further finishes in RAL 3020, 5010, and 7016 available without additional cost.



Worktop

82290



Cabinet with 6 drawers

82295



Cabinet with 2 drawers and 1 door

Hexagon workbench with worktop	82290	...	82295	...
Beechwood Multiplex 40 mm	F #	505	F #	505
Beechwood Multiplex 50 mm	F #	506	F #	506
Solid beechwood 40 mm	F #	507	F #	507
Solid beechwood 50 mm	F #	508	F #	508



Facility Equipment

82300

System workplace



Type

- Workbench top beechwood Multiplex
- Support made of stable square pipe 45 x 45 x 2 mm, 800 mm high
- Tool cabinet with 6 ball-bearing mounted drawers

Finish

- Housing/support RAL 7035 light grey
- Drawers RAL 5012 light blue
- Powder-coated

Note:

Not assembled, easy assembly.
Fitting assortments, see cat.-page 82.16,
cat.-no. 82345.



82300

Worktop L x W mm	Height up to top upper edge plate mm	Plate	Plate thickness mm	Number of drawers x height mm	Internal drawer dimensions W x D mm	82300	...
1500 x 700	840	Multiplex beechwood	40	1x60, 2x90, 2x150, 1x180	437 x 513	F #	502

82310 - 82312

Workbench plates

82310

Type

Multiplex beechwood worktop

- Made of multi-layer, waterproof glued beechwood
- With even strength in longitudinal and transversal direction

82311

Type

BMP - ANKE solid beechwood worktop

Thanks to the unique production method:

- Extremely long service life
- Robust and resistant
- Extremely durable
- Can be resanded many times
- Oiled surface
- Glued and pin fixed on the longitudinal side

Note:

Beechwood tops up to a length of 4,20 m available on request. Further dimensions available on request.

82312

Type

UBP universal worktop

- With ABS edge
- Wear resistant and anti-static
- Short-term resistance against light acids and alkalines as well as heat up to approx 250° C
- Long-term resistance against grease and oils

82310



82311



82312



Plate size L x W x D mm	Multiplex		Beechwood		Universal	
	82310	...	82311	...	82312	...
1500 x 700 x 40	F #	401	F #	101	F #	101
1500 x 700 x 50	F #	404	F #	201	F #	102
1500 x 750 x 40	F #	407				
2000 x 700 x 40	F #	402	F #	102	F #	103
2000 x 700 x 50	F #	405	F #	202	F #	104
2000 x 750 x 40	F #	408				
2500 x 700 x 40	F #	403	F #	103		
2500 x 700 x 50	F #	406	F #	203		
2500 x 750 x 40	F #	409				
3000 x 700 x 40			F #	104		
3000 x 700 x 50			F #	204		

82313

Corner workbench plates

Type

- Solid beechwood
- Oiled on both sides
- Framework-type glued
- Bevelled
- Delivery without top fittings

82313 101



82313 102

Corner	Plate thickness mm	82313	...
90°	40	F #	101
135°	40	F #	102



82217

Flanged Edges

Type

Beechwood multi-layered wood, oiled. Overall height 90 mm, 50 mm excess length of workbench top. 14 mm thick.

82217

Length mm	82217	...
1500	#	101
2000	#	102

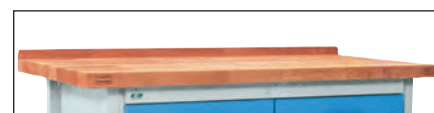

82315

Workbench Support



Type

Made of stable U-sectional steel profile 80 x 50 x 2 mm.

Standard finish:

RAL 7035 light grey, powder-coated.

82315



H x D mm	82315	...
800 x 600	#	602

82316

Cross Strut



Type

Made of sheet steel, lacquered, incl. of assembly material. Adjustable.

Use

For stabilizing modular worktables.
For worktables with a width of 1500 and 2000 mm.

82316



Width mm	82316	...
1500 - 2000	#	201

82318

Workbench supports, adjustable in height



Type

Made of stable U-sectional steel profile 80 x 50 x 2 mm. Adjustable in increments of 25 mm. With screw connection.

Standard finish:

RAL 7035 light grey, powder-coated.

82318



H x D mm	82318	...
600 - 950 x 600	#	602

82320

Vice Cupboard for Vice Folding Unit (Empty)



Type

Made of sheet steel.

Standard finish:

RAL 7035 light grey, powder-coated.

Scope of supply: **without** bench vice and height adjustment unit.

Note:

Bench vices Brockhaus Heuer see cat.-no. 53632 and 53633.
Folding and height adjustment units see cat.-no. 53650.

82320



External dimensions H x W x D mm	82320	...
800 x 320 x 680	F #	602

82328

Drawer cabinets, empty housings



Type

Centralised locking and drawer stop. Housing made of sheet steel, built-in cross section bars take the slides and provide maximum stability. **Base area 572 x 600 mm.** Without drawers (see cat.-no. 82330). Drawers with different front heights can be used.

Standard finish:

RAL 7035 light grey, powder-coated.

Note:

The sum of the drawer front heights must be the same as the useable height of the housing.
Further finishes in RAL 3003, 5010, 7016, 5012 and 6011 without additional cost (not in stock).

82328



External dimensions H x W x D mm	Useable housing height mm	82328	...
380 x 572 x 600	300	F #	701
470 x 572 x 600	390	F #	702
650 x 572 x 600	570	F #	703
800 x 572 x 600	720	F #	704

82330

Drawers

Type

- Made of sheet steel
- Roller guides
- Roller ball bearing slides
- Complete with sliding bars
- Perforated base
- Side walls with slotted rails
- Internal drawer dimensions W x D 437 x 513 mm

Standard finish:

RAL 5012 light blue, powder-coated.

82330 701-707

Type

- Drawers with 85% extension, up to 60 kg load capacity

82330 101-106

Type

- Drawers with 100% extension, up to 100 kg load capacity

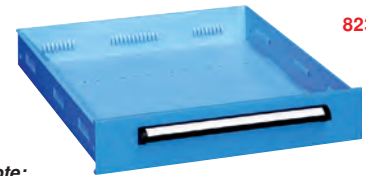

82330

Note:

Drawer fittings see cat.-no. 82345.

Further finishes in RAL 3020, 5010 and 7016 without additional cost (not in stock).

Front height mm	Useable height mm	Unit height mm	82330	...	82330	...	Front height mm	Useable height mm	Unit height mm	82330	...	82330	...	
60	40	40	#		701		180	160	130	#		705	#	104 NEW
90	70	70	#		702	#	240	220	130	#		706	#	105 NEW
120	100	100	#		703	#	300	280	130	#		707	#	106 NEW
150	130	100	#		704	#								

82335

Tool Cabinets



Type

- Centralised locking and drawer stop

Housing

- Made of sheet steel
- Built-in cross section bars on the sides take the slides and provide maximum stability

- Base area 572 x 600 mm

Drawers

- Made of sheet steel
- Roller guides
- Roller ball bearing slides
- Complete with sliding bars
- Perforated base
- Side walls with slotted rails
- Internal drawer dimensions W x D 437 x 513 mm

Standard finish:

Housing RAL 7035 light grey, Drawers RAL 5012 light blue, Powder-coated

82335 701-735

Type

- Drawers with 85% extension, up to 60 kg load capacity

82335 901-935

Type

- Drawers with 100% extension, up to 100 kg load capacity

Note:

Wheel system for drawer cabinets see cat.-no. 82356.

Drawer fitting assortments see cat.-no. 82345.

Overhead cabinet H 380 - 655 can be mounted under a worktop.

Further finishes in RAL 3020, 5010 and 7016 without additional cost (not in stock).

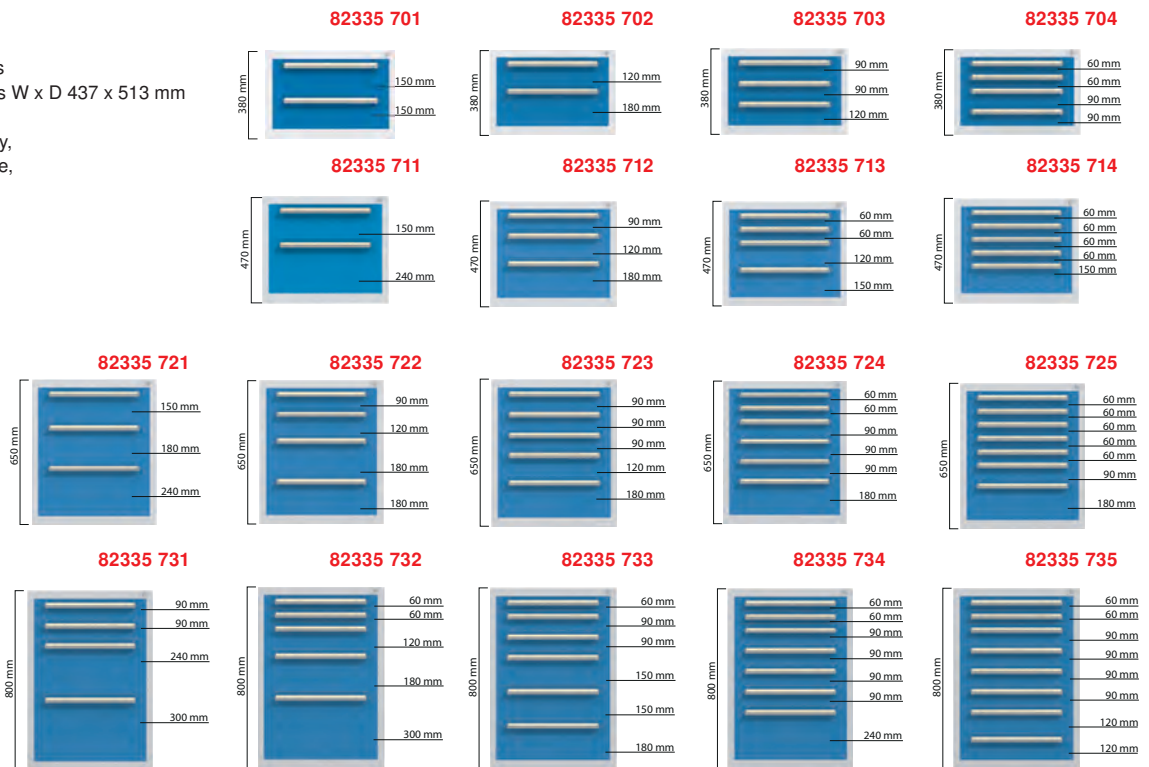

H x W x D mm	82335	...	82335	...	H x W x D mm	82335	...	82335	...
380 x 572 x 600	F #	701	#	901 NEW	650 x 572 x 600	F #	722	#	922 NEW
380 x 572 x 600	F #	702	#	902 NEW	650 x 572 x 600	F #	723	#	923 NEW
380 x 572 x 600	F #	703	#	903 NEW	650 x 572 x 600	F #	724	#	924 NEW
380 x 572 x 600	F #	704	#	904 NEW	650 x 572 x 600	F #	725	#	925 NEW
470 x 572 x 600	F #	711	#	911 NEW	800 x 572 x 600	F #	731	#	931 NEW
470 x 572 x 600	F #	712	#	912 NEW	800 x 572 x 600	F #	732	#	932 NEW
470 x 572 x 600	F #	713	#	913 NEW	800 x 572 x 600	F #	733	#	933 NEW
470 x 572 x 600	F #	714	#	914 NEW	800 x 572 x 600	F #	734	#	934 NEW
650 x 572 x 600	F #	721	#	921 NEW	800 x 572 x 600	F #	735	#	935 NEW



Drawer cabinet accessories

82340

Tool Cabinets with Doors



Type

Supplied with ball-bearing mounted drawers.

Doors reinforced, door opening left, strong hinges, lockable with cylinder lock, 2 keys.

Internal drawer dimensions W x D 437 x 513 mm.

Standard finish:

Housing RAL 7035, drawers and doors

RAL 5012, powder-coated.

Note:

Detailed description see cat.-no. 82328 empty housing and cat.-no. 82330 drawers.

Further finishes in RAL 3020, 5010 and 7016 without additional cost (not in stock).

82340 703



Dimensions H x W x D mm	Drawers with front height mm			82340	...
	60	90	120		
470 x 572 x 600	-	-	-	F #	702
650 x 572 x 600	-	-	1 x	F #	703
800 x 572 x 600	-	-	1 x	F #	704
650 x 572 x 600	-	1 x	1 x	F #	710
800 x 572 x 600	1 x	-	1 x	F #	712

82342

Base plinths for tool cabinets



Type

Finish:

RAL 7035 light grey, powder-coated.

Use

For tool cabinets cat.-no. 82328, 82335 and 82340.

Quality
sheet steel.

82342 603



82342 604



H x W x D mm	82342	...
50 x 570 x 600	#	603
100 x 570 x 600	#	604

82345

Drawer fitting assortments



Type

Through plates made of sheet steel, powder-coated., separating plate made from galvanised sheet steel, rounded edges.

82345

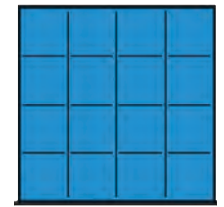
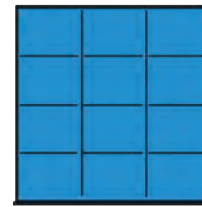

Division	Number of divisions	Number of through plates	For drawer-front height mm	82345	...
1/2	1	6	90	#	201
1/3	2	9	90	#	202
1/4	3	12	90	#	203
1/2	1	6	120 / 150	#	204
1/3	2	9	120 / 150	#	205
1/4	3	12	120 / 150	#	206

82354

Corrugated Rubber Covering

W x D mm	82354	...
545 x 600	#	201

82354

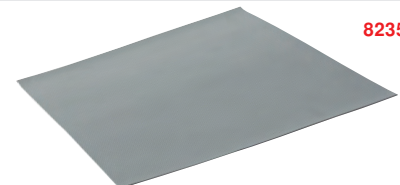

82356

Wheel system



Type

With 2 steering wheels Ø 100 mm with stop lock and 2 support rollers.

Finish: RAL 7035 light grey.

Use

With this device, the tool cabinets cat.-no. 82335 and 82340 become tool carts.

82356

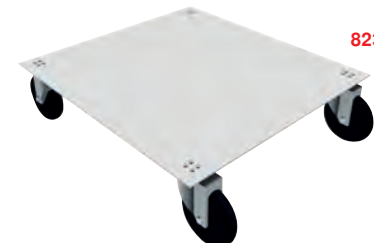

H x W x D mm	Load capacity approx. kg	82356	...
120 x 557 x 600	300	#	201

82325

Suspended drawers



Type

Sheet steel housing, drawer lockable.
With slotted rails and perforated base for dividers,
cylinder lock with 2 keys.

Standard finish:

RAL 7035/5012 powder-coated.

82325



Housing dimensions H x W x D mm	Internal drawer dimensions W x D mm	Front heights mm	Useable height mm	Load capacity kg	82325	...
150 x 557 x 600	437 x 513	140	130	80	#	502

LARGE SELECTION – SIMPLE SEARCH

Always remember! CATALOGUE VOLUME [1]
The specialist catalogue for machining and clamping technology.

Experience our extensive product range
of quality tools from **ATORN**.

ATORN[®] Performance requires quality



Info

Workplace equipment

Linking example:

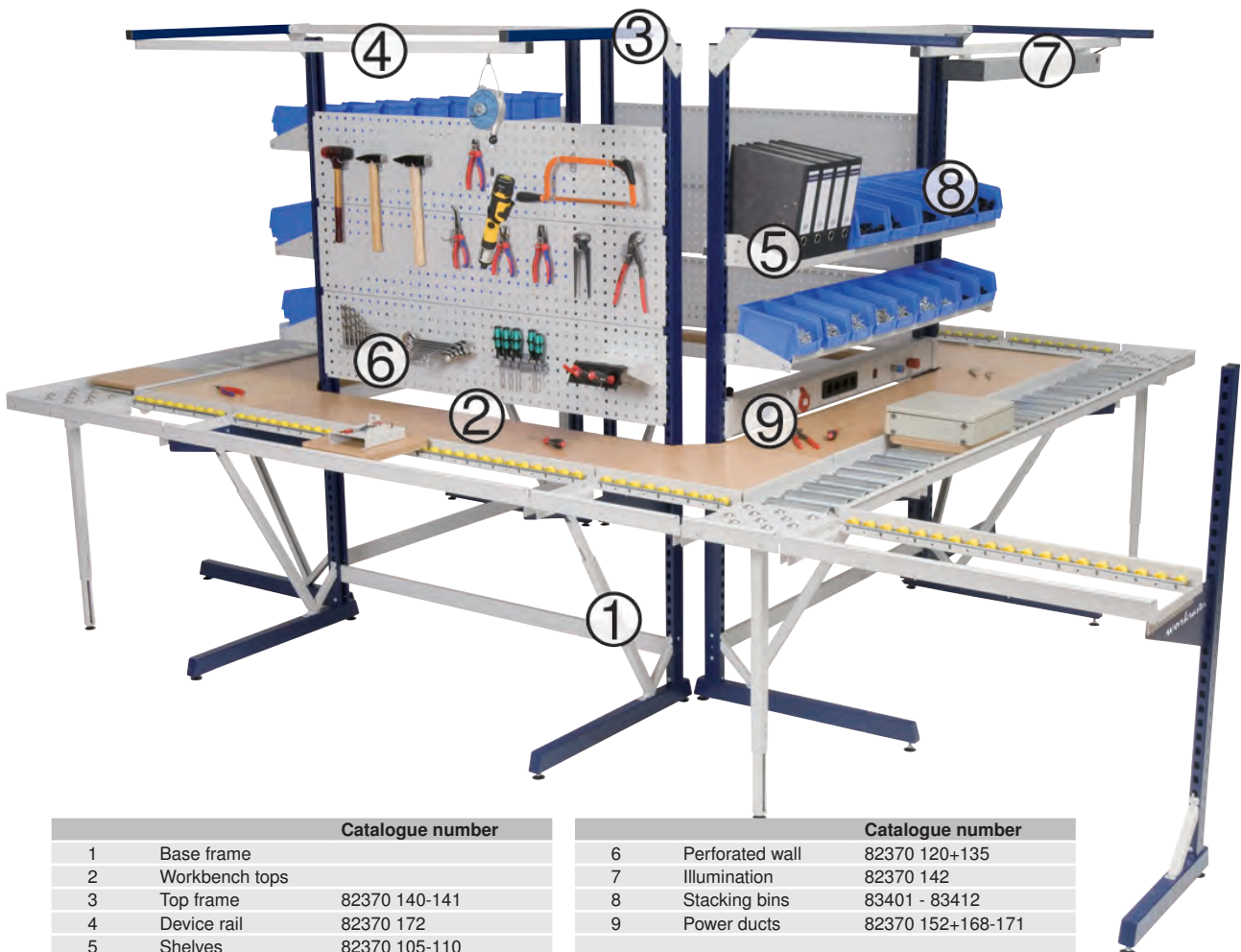

	Catalogue number
1	Base frame
2	Workbench tops
3	Top frame 82370 140-141
4	Device rail 82370 172
5	Shelves 82370 105-110

	Catalogue number
6	Perforated wall 82370 120+135
7	Illumination 82370 142
8	Stacking bins 83401 - 83412
9	Power ducts 82370 152+168-171

Facility Equipment

Info

The multi-purpose wall

- Individual for every workplace, e.g., in the development, production, assembly, shipping, etc..
- Existing workplace systems or workbenches can be converted or retrofitted at any time thanks to the modular principle.
- Comprehensive accessories offer a wide range of combination options
- The workplaces themselves are supply completely mounted

		Catalogue number
1	Support pillars	82370 164-167
2	Top frame	82370 140-141+173
3	Device rail	82370 172
4	Illumination	82370 142
5	Perforated wall	82370 120-135
6	Shelves	82370 105-110
7	Magnet walls	82370 121-136
8	Power ducts	82370 152+168-171
9	Stacking bins	83401 - 83412

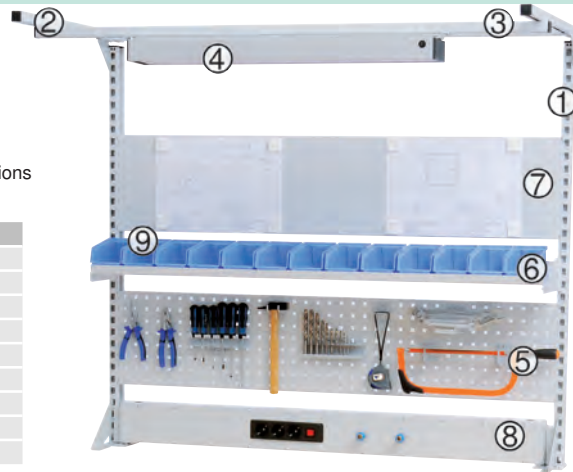

82371

Multi-walls and Workline worktables

82371 100-103

Multi-purpose wall

Type

- Finish RAL 7035 light grey

Note:

Suitable for assembly and workbench tops with abench top thickness of min. 40 mm. Mounting rails for less thick workbench tops available on request. Supplied without decoration, storage bins and hooks. Multi-wall accessories, see cat.-no. 82370.

Type	Dimensions L x W x H mm	Table top Load capacity approx. kg	82371	...
Multi-wall, 9-part	1250 x 1500 x 60	-	F #	100
Multi-wall, 9-part	1250 x 1500 x 60	-	F #	101
Multi-wall, 11-part	1250 x 2000 x 60	-	F #	102
Multi-wall, 16-part	1250 x 1500 x 60	-	F #	103
Workline worktable	1500 x 750 x 735-1100	200	F #	200
Workline worktable	2000 x 750 x 735-1100	200	F #	201
Workline worktable	1500 x 750 x 735-1100	200	F #	202

82371 200-202

Workline worktables

82371 101+200

82371 102+201

82371 103+202



Facility Equipment

For assembly on workbenches with a min. width of	82371 100 9-part 1500 mm	82371 101 9-part 1500 mm	82371 102 11-part 2000 mm	82371 103 16-part 1500 mm
Support rail 1,250 mm	2x	2x	3x	2x
Top frame	1x	1x	1x	1x
Device rail	1x	1x	1x	2x
Lighting 2x 36W	1x	1x	1x	1x
Energy channel with 2 compressed air connections and 3 earthed power socket with on / off switch	1x	-	-	-
Energy channel with 3 earthed power socket with on / off switch	-	-	1x	1x
Perforated panel	1x	1x	1x	1x
Shalf 220 mm / 320 mm	1x / -	1x / 1x	2x / -	1x / 1x
Magnet wall	1x	1x	-	-
Roller shutter cabinet	-	-	1x	-
Trolley	-	-	-	1x
Spring supports	-	-	-	1x
Pivot arm holder	-	-	-	2x
Pivot arm with monitor and keyboard holder	-	-	-	1x
Pivot arm with storage tray	-	-	-	1x

Use

For designing your workplaces ergonomically and individually using the module system. Assembly of the accessories on worktables and support rails.

82370 164-167**Support rails**

30 x 60 mm, reinforced by U profile tube, incl. fastening material. Suitable for assembly on workbench tops with a min. bench thickness of 40 mm. Thinner workbench tops on request. For the assembly on 2 m workbench tops, 3 support rails are required (centre support rail, see cat.-no. 82370 165+167).

82370 140-141+173**Top frame**

With screwed in reinforcements.

82370 172**Device rail**

Is bolted under the top frame and is used to mount the lighting (cat.-no. 82370 142), the trolley or the spring support (optionally available).

82370 142**Illumination**

With connecting cable 2,9 m and plug. A mounting rail is required to mount the lamp.

82370 105-110**Shelves**

Inclination (0°, 10° and 20°) and height adjustable, incl. flanged edge.

82370 120-136**Perforated and magnetic panels**

For installation between the support rails.

82370 150**Energy channel holder**

For installing the energy channels cat.-no. 82370 168-171.

82370 168 + 152**Energy channels**

- 3 earthed power sockets
- 1 on / off switch
Not wired. For installation between the support rails with the holder cat.-no. 82370 150.

82370 170-171**Energy channels**

- 3 earthed power sockets
- 1 on / off switch
- 2 compressed air connections
Not wired. For installation between the support rails with the holder cat.-no. 82370 150.

82370 155**Swivelling arm holder**

For mounting the swivel arms cat.-no. 82370 160-163. Fastening to the support rails.

82370 160-163**Swivel arms**

For fixing between the support rails with the holder cat.-no. 82370 155.

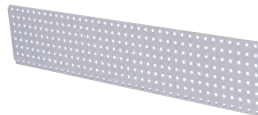
82370 164-167**82370 140-141+173****82370 172****82370 142****82370 105-110****82370 120+135****82370 121+136****82370 168+152****82370 170-171****82370 155****82370 160****82370 161****82370 162****82370 163**

Designation	W x D x H mm	Description	82370	...
Mounting rail	Height 950 mm	right side	#	164
Mounting rail	Height 950 mm	left side and middle	#	165
Mounting rail	Height 1250 mm	right side	#	166
Mounting rail	Height 1250 mm	left side and middle	#	167
Top frame	Width 1000 mm	-	#	140
Top frame	Width 1500 mm	-	#	141
Top frame	Width 2000 mm	-	#	173
Device rail	Width 2000 mm	-	#	172
Lighting	1280 x 135 x 60	2x 36W, 1100 Lx	#	142
Shelf	1000 x 220	-	#	105
Shelf	1000 x 320	-	#	106
Shelf	1000 x 420	-	#	107
Shelf	1500 x 220	-	#	108
Shelf	1500 x 320	-	#	109
Shelf	1500 x 420	-	#	110
Perforated panel	1000 x 12 x 302	-	#	120
Perforated panel	1500 x 12 x 302	-	#	135
Magnetic panel	1000 x 12 x 302	-	#	121
Magnetic panel	1500 x 12 x 302	-	#	136
Energy channel holder	33 x 38 x 117	-	#	150
Energy channel	1000 x 60 x 130	3x earthed outlets, 1x On / off switch	#	168
Energy channel	1500 x 60 x 130	3x earthed outlets, 1x On / off switch	#	152
Energy channel	1000 x 60 x 130	3x earthed outlets, 1x On / off switch, 2x compressed air	#	170
Energy channel	1500 x 60 x 130	3x earthed outlets, 1x On / off switch, 2x compressed air	#	171
Holder for swivelling arm	-	-	#	155
Swivelling arm with perforated panel	680 x 60 x 400	Dimensions including swivelling arm	#	160
Swivelling arm with monitor and keyboard holder	700 x 365 x 370	Dimensions including swivelling arm	#	161
Swivelling arm with shelf and ribbed rubber	420 x 300 x 20	Dimensions including swivelling arm	#	162
Swivelling arm with storage plate	600 x 350 x 20	Dimensions including swivelling arm	#	163



Floor matting

82405

Safety Wooden Floor Matting

Type

- With anti-slip system
- Solid beechwood
- Safe to step on
- Can be rolled together
- Flexible
- Insulating
- Maintenance free
- Wooden strips artificially dried
- Warp-proof and tension-free
- Good damping properties
- Elastic
- Long service life
- Rubber supports resistant against petrol and oil
- Steel tension ropes made of stainless steel
- 5-year warranty

Use

For highest demands when it comes to occupational medicine and safety.

82405 101-104

With ramp wedges on the short sides and bevelled edge on long side.

82405 201-204

Without ramp wedges on the short sides and without bevelled edge on long side.

82405 101-104

82405 201-204

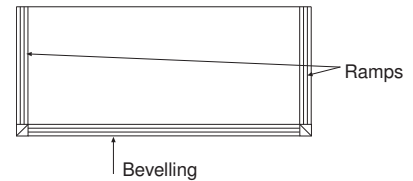
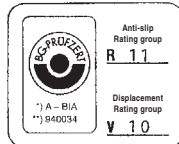

Dimensions L x W mm	Matting width mm	Matting height mm	Support rubber	82405	...	82405	...
1500 x 800	80	35	2 rows	F	101	F	201
2000 x 800	80	35	2 rows	F #	102	F	202
1500 x 1000	80	35	3 rows	F #	103	F	203
2000 x 1000	80	35	3 rows	F	104	F	204

82410 - 82412

Plastic Floor Matting

Type

- Robust floor matting made of polyethylene
- Material thickness 25 mm
- Easy to install and simple to clean
- Individual mats can be plugged together to larger surfaces
- Grooved profile surface for safe grip
- Can be driven over by a forklift and workshop trolley, easy to clean
- Load capacity up to 40,000 kg/m²
- Temperature resistant from -10°C to +80°C
- Corner pieces and ramp wedges optionally available.

Use

- In the different industrial facilities, ideal for tool machines
- Insulates against cold and wet industrial floors
- Also suitable for sanitary facilities.

82410

Floor matting, 1200 x 600 x 25 mm.

82411

Ramp wedges, 600 x 112 mm.

82412

Corner pieces, 112 x 112 mm.

82410



82411

82412

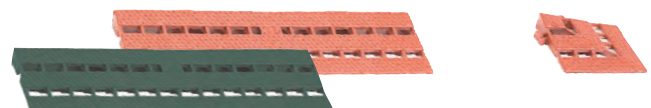

	Floor matting		Ramps		Corner pieces	
Colour	82410	...	82411	...	82412	...
green		101		101		101
red		102		102		102

LARGE SELECTION – SIMPLE SEARCH

Always remember! CATALOGUE VOLUME [1]

The specialist catalogue for machining and clamping technology.

Experience our extensive product range of quality tools from **ATORN**.

ATORN® Performance requires quality





Anti-fatigue
Matts that stimulate blood circulation and prevent stress being caused to the bottom of your feet, back and muscle groups.



Anti-slip
These mats ensure for a special surface structure for increased slip resistance.



Protection
Reduces damage from objects falling on the ground and protects the floor.



Insulation
Insulation against cold, heat, vibration and noise.



Access by wheeled vehicles
Matts suitable for access by wheeled vehicles (e.g., trolleys).



High loading
Recommended for high loading in industrial areas.



Average loading
Recommended for average loading in industrial areas.



RedStop™
This unique technology prevents the mats from slipping on floors.



NFSI®
Tested and certified by the National Floor Safety Institute.



ESD
Electrostatic charging is absorbed and dispersed. Protects sensitive technical devices.



Fire protection
The mats prevent fire from spreading and are heat resistant (safeguarded by tests from independent test institutes).



Welding
Suitable for welding workplaces, manufactured from hard wearing rubber.



Plug-in system
Pluggable tiles makes assembly in the desired shape easier on location. Can be installed as a loose mat or over the entire floor.



Drainage
The open structure permits fluids and soiling to drain away. Ensures for safe stepping in wet surroundings.



Oil resistant
Suitable for environments where gear oil is used.

82414

Durable anti-fatigue mats Cushion Trax®



Type

- 4.7 mm PVC surface is bonded fixed with the 9.3 mm thick and durable backs made of microcells
- Material thickness 14 mm
- Fire protection class Bfl-S1 according to EN 13501-1
- Supplied with 4 bevelled safety edges
- R10 anti-slip surface according to DN 51130 and BG Rule BGR181
- With RedStop™: Anti-slip underlay in order to prevent the mats from slipping

Use

- For heavy-duty use
- For dry industrial environments
- Chequered plate offers a good traction when turning
- For ergonomic use with intensive use

Note:

Customised sizes available on request.



Colour	Black / yellow		Black	
	82414	...	82414	...
Dimensions L x W mm	F #		F #	
600 x 910	F #	201	F #	301
910 x 1500	F #	202	F #	302
910 x 2000	F #	203	F #	303
910 x 3000	F #	204	F #	304
910 x 6000	F #	205	F #	305

82414 201-205

82414 301-305

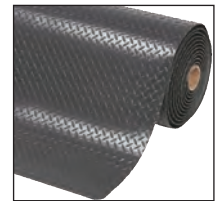
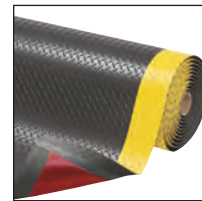

82415

Anti-fatigue Bubble Sof-Tred™



Type

- Material thickness 12.7 mm
- Supplied with 4 bevelled safety edges
- R10 anti-slip surface according to DIN 51130 and BG Rule BGR181

Use

- For average loading
- For dry areas
- Wear-resistant surface Dyna-Shield™ increases the service life by 50%, compared with conventional microcell vinyl floorings
- For ergonomic use with average use

Note:

Customised sizes available on request.



Colour	Black / yellow		Grey	
	82415	...	82415	...
Dimensions L x W mm	F #		F #	
600 x 900	F #	301	F #	401
910 x 1500	F #	302	F #	402
910 x 2000	#	303	#	403

82415 301-303

82415 401-403

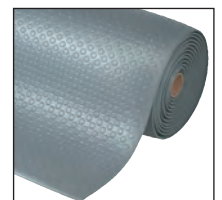
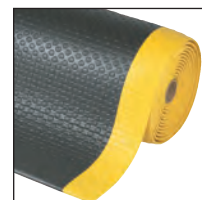

Floor matting

82406

Durable, conducting anti-fatigue mats Diamond Stat™



Type

- R10 anti-slip surface according to DIN 51130 and BG Rule BGR181
- With RedStop™: Anti-slip underlay in order to prevent the mat from moving
- Fire category Cfl-S1 according to EN 13501-1
- Fulfills IEC 61340-4-1 (category DIF), measured resistance R_g 10^6 - 10^9 Ohm, R_p 10^6 - 10^9 Ohm
- Material thickness 14 mm (4.7 mm PVC laminated to 9.3 mm microcells vinyl)
- Supplied with 4 bevelled safety edges

Use

- For the highest loading
- For dry industrial environments
- Safe and quick discharge of static charging in order to avoid overvoltage damage on sensitive electronic parts or devices
- Diamond plate top surface ensures for high anti-slip properties

Note:

Equipped with a 10 mm snap fastener and earthing cable.
Customised sizes available on request.



Colour	Black	
Dimensions L x W mm	82406	...
600 x 910	F #	101
910 x 1500	F #	102
910 x 3000	F #	103



82406



82407

ESD protective table mats Anti-Stat P.O.P.™



Type

- Material thickness 6.4 mm
- Fulfills EOS/ESD-S4, measured resistance of the surface R_g 107 Ohm, R_p 108 Ohm
- Electrostatic charging (walking test), fulfils ISO 6356 and EN 1815
- Microcellular vinyl foam with conducting properties

Use

- With earthing cable on request
- Work surface made from vinyl, that absorbs electrostatic charging
- Protects worktables and avoids overvoltage damage on sensitive devices

Note:

Customised sizes available on request.

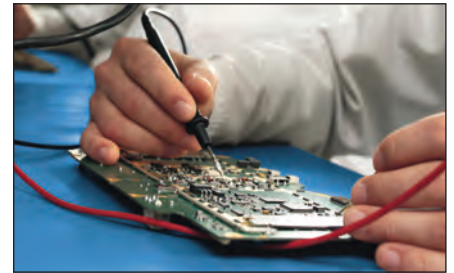

Colour	Blue	
Dimensions L x W mm	82407	...
600 x 1000	F #	101
760 x 1000	F #	102
910 x 1000	F #	103

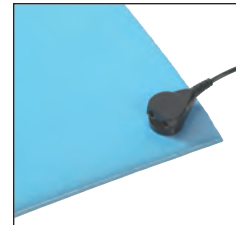

82407



82408

ESD accessories



82408 101

Earthing cable

Type

- Length 4.5 m
- Complies with the requirements of ANSI/ESD S-20.20, EIA 625 and ANSI/ESD S61

Use

- Joins 1 to 2 wrist straps and a table mat with the earthing
- Easy to attach: Easily attached to the mat with a snap fastener and the spiral cable and then to the earth

82408 102

Earthing connector

Type

- 1 Meg resistance 3 x 10 mm push connection

Use

- Connects the earthing cable to the earthing point

82408 103

Helix cable

Type

- Length 1.8 m
- 1 Meg resistance 10 mm snap fastener

Use

- Connects the wrist strap with the earthing snap fastener on the table mat

82408 104

Wrist strap

Type

- Complies with the requirements of EOS/ESD S1, MIL-STD-1686 and EIA 625

Use

- Joins the user with the earthing and thus controls its electrostatic discharge
- Safe discharge from the person



82408 101



82408 102



82408 103



82408 104



Designation	82408	
Earthing cable	F #	101
Earthing connector	F #	102
Spiral cable	F #	103
Wrist strap	F #	104

82409

Ergonomic workplace mats 100% nitrile rubber Safety Stance™

Type

- 100% nitrile rubber
- Resistant against most industrial oils and chemicals
- Grippy anti-slip surface R10 according to DIN 51130 and BG Rule BGR181
- Supplied with 3 integrated, bevelled, orange safety edges
- Silicone-free and thus suitable for vehicle-paintshops
- Material thickness, 22 mm

Use

- For the highest loading
- For moist, oily industrial areas
- Robust rubber mixture suitable for multi-shift operation
- The matting cannot be moved



Note:

Customised sizes available on request.

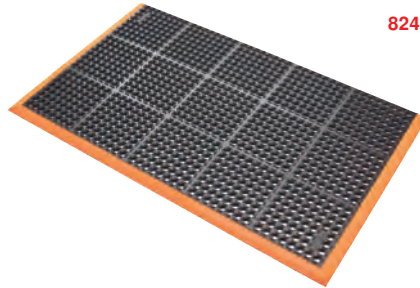

82409

NEW

Nitrile rubber

Dimensions L x W mm	82409	...
660 x 1020	F #	101
970 x 1630	F #	102
970 x 3150	F #	103

82418

Ergonomic workplace mats 100% nitrile rubber Safety Stance Solid™

Type

- 100% nitrile rubber
- Resistant against most industrial oils and chemicals
- Grippy anti-slip surface R10 according to DIN 51130 and BG Rule BGR181
- Supplied with 3 integrated, bevelled, orange safety edges
- Silicone-free and thus suitable for vehicle-paintshops
- Material thickness 20 mm

Use

- For the highest loading
- For dry industrial areas
- The unique Diamond Grid™ surface structure ensures for good stance
- Can be positioned individually and must not be installed



Note:

Customised sizes available on request.

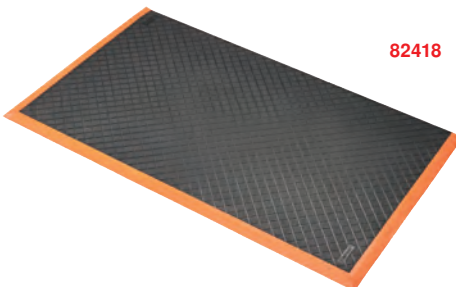

82418

NEW

Nitrile rubber

Dimensions L x W mm	82418	...
660 x 1020	F #	101
970 x 1630	F #	102
970 x 3150	F #	103

82419

Ergonomic, individual mats Skystep™

Type

- Individual mats that do not have to be installed on-site
 - With integrated edge strips on all 4 sides
 - Material thickness 13 mm
 - Made from a high-quality rubber mixture
 - Slip resistant surface R9 according to DIN 51130 and BG Rule BGR181
- Available in 3 different rubber mixtures:**
- Natural rubber
 - 100% nitrile rubber, oil resistant
 - Natural rubber with ESD

Use

- For average loading
- For dry, individual standing workplace-areas

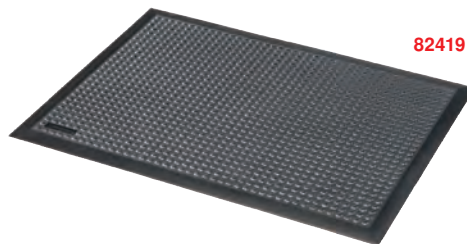

82419

NEW



Dimensions L x W mm	Natural rubber		Nitrile rubber		ESD	
	82419	...	82419	...	82419	...
600 x 900	F #	101	F #	201	F #	301
900 x 1200	F #	102	F #	202	F #	302
900 x 1500	F #	103	F #	203	F #	303

Floor matting

82426

Ergonomic plug system with nubbed surface Skywalker HD™

Type

- Slip resistance R9 according to DIN 51130
- Easy to install thanks to its unique design
- Rubber tiles of 910 x 910 mm easy to connect to each other
- Material thickness 13 mm

Available in 5 different rubber mixtures:

- Natural rubber
- 100% nitrile rubber
- Natural rubber with ESD
- Nitrile rubber with ESD, oil-resistant, Bfl-S1
- 100% nitrile rubber, oil-resistant, Bfl-S1

Use

- For the highest loading
- For dry areas
- Simple customised production by the 300 x 300 mm grid on the bottom

Note:

Accessories and customised production available on request.

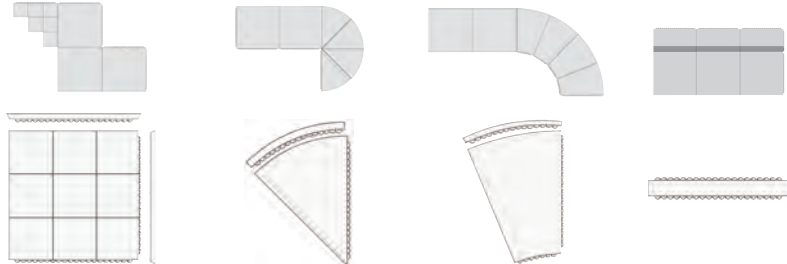
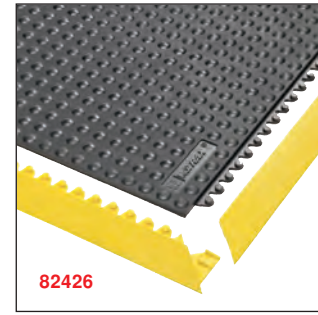

Quadratic 910 x 910 mm 45° Inner angle 910 mm x 45° 22,5° Outer angle 910 mm x 22.5° Safety marking 910 x 100 mm

Rubber mixture	82426	...	82426	...	82426	...	82426	...
Natural rubber	F # 201		F # 301		F # 401			
100% nitrile rubber	F # 202		F # 302		F # 402		F # 501	
ESD natural rubber	F # 203		F # 303		F # 403			
ESD nitrile rubber, oil-resistant Bfl-S1	F # 204		F # 304		F # 404			
100% nitrile rubber, oil-resistant Bfl-S1	F # 205		F # 305		F # 405			

Edge strip	910 x 50 mm	...	45° Inner angle	...	22.5° Outer angle	...
Male, yellow	F # 601		F # 801		F # 901	
Male, black	F # 603		F # 802		F # 902	
Female, yellow	F # 602					
Female, black	F # 604					

82427

Ergonomic plug system Cushion Ease Solid™

Type

- Slip resistance R9 according to DIN 51130
- Material thickness 19 mm
- Anti-slip orange skin surface for maximum anti-fatigue effect
- 910 x 910 mm plug-system permits unique customised production possibilities

Available in 5 different rubber mixtures:

- Natural rubber
- 100% nitrile rubber
- Natural rubber with ESD
- Nitrile rubber with ESD, oil-resistant, Bfl-S1
- 100% Nitrile rubber with ESD, oil-resistant, Bfl-S1

Use

- For the highest loading
- For dry industrial loading

Note:

Customised sizes available on request.

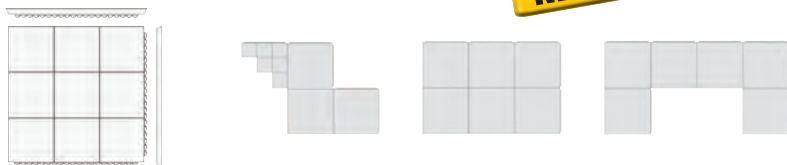

Quadratic 910 x 910 mm 910 x 50 mm

Rubber mixture	82427	...	Edge strips	82427	...
Natural rubber	F # 201		Male, yellow	F # 302	
100% nitrile rubber	F # 202		Male, black	F # 301	
ESD natural rubber	F # 203		Female, yellow	F # 304	
ESD nitrile rubber oil-resistant Bfl-S1	F # 205		Female, black	F # 303	
100% nitrile rubber oil-resistant Bfl-S1	F # 204				

The Sunnex matting system was developed in order to reduce pains coming from standing up for a long time.
Ergonomics at the workplace is a very important factor, for both the health of the work force and productivity.

Use

Work is less tiring and muscles and joints of feet, legs and particularly the back ache less thanks to the Sunnex matting system.

Type

- Manufactured according to the air-cushion principle, from flexible **nitrile rubber, grey**
- They are particularly resistant against wear, cleaning detergents, cutting oils and hot chips
- Anti-slip
- Noise damping
- Heat insulating
- Shock damping
- The closed surface and the high friction - coefficient ensures that dirt is not easily absorbed and that they are easy to clean
- The bevelled edge can be rode over by forklifts and other mobile transport devices
- **The basis of the matting system consists of three 3 parts:**
- **1 x the centre piece (B) and 2 outer pieces (A)**
- They are connected together with dovetail couplings that permits a good and reliable connection
- No tools are needed for the assembly

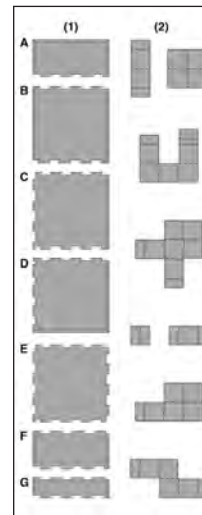
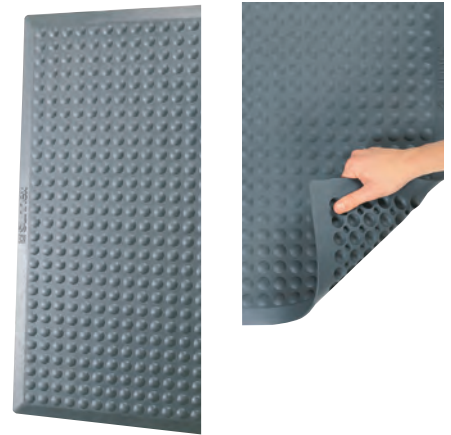
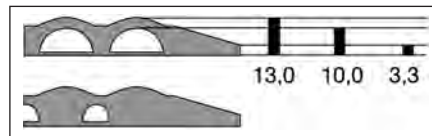
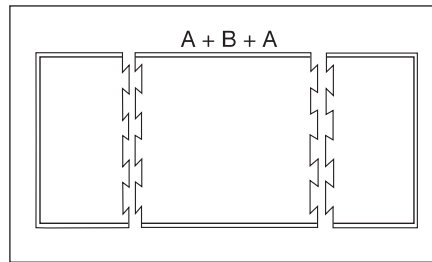

(1) = Standard pieces,
(2) = Example.

Description	Type	Dimensions L x W mm	Basic set		Separate	
			82416	...	82417	...
Basic set	A + B + A	1500 x 750		101		
Corner	A	750 x 375				101
Centre piece	B	750 x 750				102
Edge	C	750 x 750				103
Corner	D	750 x 750				104
Centre piece	E	750 x 750			#	105
Extension	F	750 x 375				106
Extension	G	750 x 175				107

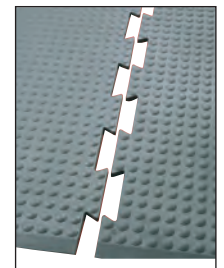

Type

-BLACK-CAT- was developed following the latest results in working safety research.
Anti-slip matting sticks to floors, without adhesion, almost in any position and on nearly all materials.
Made of raw materials, without having any restricted contains by food law, can be washed up to a temperature of 60°, just lay out for drying.
Form can be cut accurately by using scissors, extremely wear-resistant.
Temperature-resistant from -25°C - +50°C.
Colour: Black.

Use

-BLACK-CAT-, a multi-purpose product, suitable e.g. for:
tool carts, workbenches, tool boxes, tool trays on machines, car boots, caravans, conveyor belts, loading and transport securing, all types of drawers.
As non-slip surface when planing, drilling, grinding, sawing, filing etc.

Note:

Other matting dimensions, 20 m rolls or rolls with special dimensions are available on request.

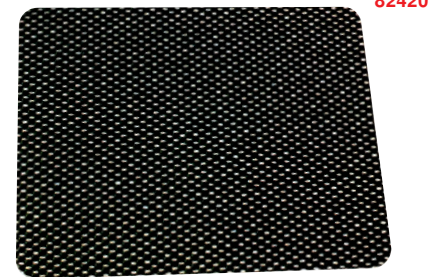

Dimensions L x W x D mm	Matting		10 m roll	
	82420	...	82425	...
1200 x 600 x 4		101		
1200 x 900 x 4		102		
10000 x 500 x 4				110
10000 x 600 x 4				111
10000 x 1000 x 4				112



Swivel chairs

82430 - 82431

Workshop stools



82430

Workshop stools

Type

4-legged stool, stable, frame made of moulded strip steel, round seat made of plywood 350 mm Ø, laminated glued and natural finish. Seat height 500 mm. Made in compliance with DIN 68877.

82431

Workshop Swivel Stool

Type

With height adjustment by covered spindle, with double spindle guide, round wooden seat 350 mm Ø. Seat height 570 - 450 mm. Made in compliance with DIN 68877.

	Stool		Swivel stool	
	82430	...	82431	...
	#	201	#	101

82430



82431



82447

Pneumatic assembly roller stool

Type

- The high-quality pneumatic height adjustment allows low-fatigue working in sitting heights of 38 - 51 cm
- The large tool tray with 420 mm Ø can facilitate small tools and repair material
- 2 tool trays can be turned by 360°
- Easily maneuvered

Load capacity kg	Castor Ø mm	Weight kg	82447	...
150	75	6,5		201

82447



82433

Swivel stool

bimos

Type

- Foot rest made of high-quality sectional steel tubing.
- Seat height adjustable by means of safety gas spring.
- Easy-to-operate all-around handle under the seat.
- Large seat base.
- With wheels with load-dependend brakes for hard floors. Sturdy and stable.

82433 101

Type

Top artificial leather, washable, soft, comfortable. Extra edge protection.

82433 301

Type

Top structural foam, robust, washable, tough.

Top	Seat height approx. mm	Seat Ø mm	Castors	82433	
Artificial leather	460 - 630	400	x	#	101
Structural foam	460 - 630	350	x	#	301

82433 101



82433 301



82454

Sitting and standing chairs DIN 68877 Flex

bimos

Type

- Infinite height adjustment using the gas spring
- Can be swivelled 360°
- Integrated backrest for maximum relief
- Soft, wipeable and resistant thanks to the new Soft-Touch PU foam
- Structured waved seating surface ensures for the best possible support and sufficient ventilation
- GS mark for tested safety
- Long term guarantee of 5 years

Use

Equally suitable for sitting, standing and combination workplaces.

82454 201

Type

Feet with castors for hard floors.

82454 202-203

Use

Can be used as work stool or as standing aid. For working heights of 720 - 1,000 mm. Height of the foot ring can be adjusted without tools (only cat.-no. 82454 203).

82454 202



82454 201



82454 203



	Seat height mm	Glides	Castors	Foot ring	82454	...
Work stool	450 - 650	-	x	-	#	201
Sitting standing stool	510 - 780	x	-	-	#	202
Sitting standing stool	510 - 780	x	-	x	#	203



bimos

Type

- With Permanent- contact technology
- Foot rest made of high-quality sectional steel tubing. Very flat design
- Seat height adjustable by means of safety gas spring
- Backrest inclination easily and infinitely adjustable. Lockable in any position
- Backrest with pendulum support, automatically adjusts to the sitting position
- Backrest is infinitely adjustable in height
- Ergonomically-shaped backrest with good lumbar support
- Gas spring is covered in order to protect it from dust and dirt
- 5 year warranty

Optionally available with:

- Glides: Large wear-resistant glides. Sturdy and stable
- Castors: With castors with load-dependend brakes for hard floors
- Foot rest: High version with foot rest. Height adjustable, chrome-plated

Note:

Suitable arm rests see cat.-no. 82444 201.

82437

Type

Top laminated beechwood, washable, robust, tough.

82438

Type

Top artificial leather, washable, soft, comfortable.

82439

Type

Top cloth, breathable, soft, comfortable.

82440

Type

Top structural foam, robust, washable, resistant against mechanical load.

82437 101



82438 102



82439 102



82440 403



82437 102



82437 103



82438 101



82438 103



82439 101



82439 103



82440 401



82440 402



Seat height mm	Glides	Castors	Foot ring	Beechwood		Leather		Cloth		Foam	
				82437	...	82438	...	82439	...	82440	...
430 - 600	X	-	-	#	101	#	101	#	101	#	401
430 - 600	-	X	-	#	102	#	102	#	102	#	402
590 - 910	X	-	X	#	103	#	103	#	103	#	403

82444

Arm rests for swivel chairs Fit Special

bimos

Type

Pairs.

Use

For swivel chair Fit Special, cat.-no. 82437 - 82440.



82444

											82444	...
											#	201

When you think laterally ...



... new ideas arise.

ATORN®

Performance requires quality

www.atorn.de



Swivel chairs

82436

Swivel chairs DIN 68877 All-In-One



bimos

Type

Possibilities for adjusting the ergonomic position

- Ergonomically shaped seat and back padding
- Seat height adjustable
- Backrest height adjustable
- Backrest inclination adjustable
- Tilt position adjustable
- Synchronous technology
- Body weight setting
- Sitting depth adjustable

Technical fittings

- Height adjustable by means of gas spring
- Extra large ergonomically shaped backrest
- Stable feet, black
- GS mark for tested safety
- Long term guarantee of 5 years

Optionally available with:

- Glides: large area, made of plastic
- Castors: Double castors brake load-dependent
- Foot rest: High version with foot rest. Height adjustable, chrome-plated, scratch resistant

Note:

Suitable arm rests see cat.-no. 82436 701.

82436 301+401+501

Type

Artificial leather padding, soft and comfortable, washable and easy care.

82436 302+402+502

Type

Fabric padding, soft, breathable and wear-resistant.

82436 303+403+503

Type

PU foam, extremely wear-resistant, washable and easy care.

82436 701

Armrests

Type

Height adjustable, black. Pairs.

Use

For work swivel chair All-In-One, cat.-no. 82436 301-503.



82436 401



82436 302



82436 503



82436 701

82436 301

82436 501

82436 402

82436 502

82436 403

82436 303



Seat height mm	Glides	Castors	Foot ring	Leather		Fabric cover		Foam		Armrests	
				82436	...	82436	...	82436	...	82436	...
450 - 600	X	-	-	# 401	# 402	# 403					
450 - 600	-	X	-	# 301	# 302	# 303					
620 - 900	X	-	X	# 501	# 502	# 503					
-	-	-	-								# 701

82445 - 82446

Office swivel chair Top Pro 1



82445

Type

- Infinitely adjustable seating position with Toplift (LGA tested)
- Backrest with integrated lumbar support, infinitely height adjustable
- Special moulded seat
- Permanent contact mechanism for adjusting the backrest inclination
- Black polyamide feet with safety double castors with load-dependent brakes for carpets
- Fabric cover 100% polypropylene

Note:

Armrests, see cat.-no. 82446 101.

Hard floor castors and other fabric colours available on request.

82446

Armrests type E

Type

Pair, black.

Use

For office swivel chair Top Pro 1, cat.-no. 82445 301.

82446



82445



Seat height cm	Seat width cm	Seat depth cm	Armrest height cm	Overall height cm	Fabric cover Colour	Swivel chair	Arm rest
42 - 54	46	45	45	90 - 103	Speckled grey	82445	82446
						301	101



Facility Equipment

82463

Office swivel chair X-Pander



Type

- Design swivel chair in net optic with fitness-function
- Infinitely adjustable seating height position Toplift (LGA tested)
- Black backrest with breathable net material, height adjustment using the up-and-down-system
- Backrest sides with elastic rubber bands
- Comfortable flat seat with comfortable knee roll

- Point-synchronous mechanism, spring force can be adjusted individually to the body weight, infinitely lockable
- Footrest polyamide black incl. load-dependant braked safety double castors for carpets
- **Including height adjustable armrests, type T2** with soft pad armrest, chrome shaft
- Cover 100% Trevira CS

Note:

Hard floor castors and further fabric colours available on request.



82463

Seat height cm	Seat width cm	Seat depth cm	Armrest height cm	Overall height cm	Fabric cover Colour	82463	...
41 - 53	48	48	60	96 - 114	blue		201

82441

Office swivel chair Open Point® SY



Type

- Modern synchronous intervertebral disc swivel chair with eye-catching net optic
- Infinitely adjustable seating height position with Toplift (LGA tested)
- Design backrest with breathable net cover, height and tilt adjustment using the locking mechanism
- Comfortable intervertebral disc chair for optimum use in the pelvic area

- Point-synchronous mechanism, spring force can be adjusted individually to the body weight, infinitely lockable
- Footrest polyamide black incl. load-dependant braked safety double castors for carpets
- **Including armrest, type Q3(B)**
- Fabric cover 100% polypropylene

Note:

Hard floor castors and further fabric colours available on request.

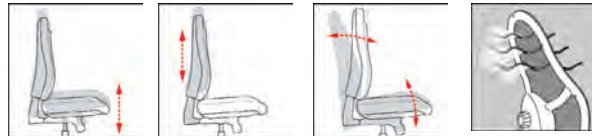

82441

Seat height cm	Seat width cm	Seat depth cm	Armrest height cm	Overall height cm	Fabric cover Colour	82441	...
43 - 51	48	48	60	103 - 111	blue		401

82450 - 82451

Office swivel chair Century Pro 5



82450

Type

- Classis intervertebral disc swivel chair with trapezium shaped backrest
- Infinitely adjustable seating height position Toplift (LGA tested)
- Ergonomic trapezium shaped backrest, infinitely height adjustable backrest via locking mechanism, with integrated lumbar support
- Special intervertebral disc seat formed orthopaedically for the optimum support in the back region
- Point-synchronous mechanism for the synchronous adjustment of the seat and backrest, infinitely lockable, spring force can be adjusted to the body weight.
- Black polyamide feet with safety double castors with load-dependend brakes for carpets
- Fabric cover 100% polyacrylic

Note:

Armrests, see cat.-no. 82451 201. Hard floor rollers and other fabric materials available on request.

82451

Arm rests type M

Type

In pairs, height adjustable, black.

Use

For office swivel chair Century Pro 5, cat. no. 82450 201.



82451



82450

Seat height cm	Seat width cm	Seat depth cm	Armrest height cm	Overall height cm	Fabric cover Colour	82450	...	82451	...
43 - 55	46	45	56	99 - 115	Black/Blue				
							201		201

82449

Glides

Use

For a solid stand of the chair. Can be retrofitted. For cat.-no. 82441, 82445, 82450 and 82463. 1 set = 5 pcs.

82449	...
#	201



82449

82456

Folding standing support Flex

bimos

Type

- Height adjustable by means of gas spring
- Sitting area made from integral foam with integrated carry handle
- Sitting area can be turned by 360°
- Seat can be tilted to the front by 10°
- With chrome-plated foldable footrest
- Long term guarantee of 5 years

Seat height mm	82456	...
680 - 840	#	201



82456

82458 - 82459

Standing support Ergo Plus 3000

KAPPEL

82458

Type

- Modern design
- Ergonomic function
- Relieves legs, back muscles and spinal column
- Prevents circulation problems, concentration problems and spinal disc degeneration
- Stable design made from plastic coated steel profiles
- Seat and backrest made from shaped multiply glued beech plywood boards
- Multi-layered air-circulating foam padding
- Breathable, wear-resistant and decorative covers
- Height adjustable 600 - 900 mm

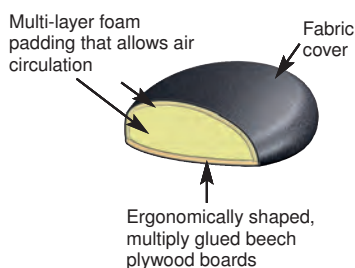

Backrest infinitely adjustable

Seat height infinitely adjustable 600 - 900 mm

Frame foot with levelling screw for setting up the standing support in a safe manner

82459

Black foot



Plug-on foot support ensures for relieving standing posture (available as an accessory)

	Fabric cover	Frame colour	82458	...	82459	...
Standing support	Skai black	jet black	#	601		
Standing support	Blue fabric	jet black	#	602		
Standing support	Techno cover	jet black	#	603		
Footrest	-	-			#	601

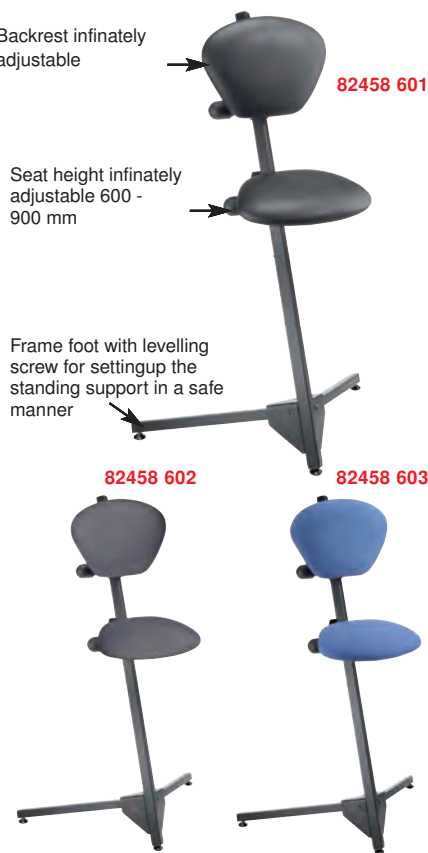

SAFETY FIRST! The current PSA catalogues



82460 - 82461

Tubular steel table and stackable chair

Use
Perfect for canteens and recreation areas.

82460
Tubular steel table
Type

Table top 25 mm thick, scratch-proof, coated with edge band made of laminated plastics. In compliance with DIN 68765 E 1 quality. Grey design, steel frame 30 x 30 mm powder-coated with structured surface RAL 7035 light grey. Legs with glides adjustable in height. Disassembled to save space, in cardboard box, easy assembly.

82461
Stackable chair
Type

Frame made of circular tube 22 mm plastic-coated RAL 7035 light grey. Seat base and back rest made of beechwood.

82460 201



82460 205



82461



Dimensions of table L x W x H mm	Dimensions of chair W x H x D mm	Table		Chair	
		82460	...	82461	...
1200 x 800 x 720	-	#	201		
1600 x 800 x 720	-	F #	205		
-	420 x 440 x 400			#	201

82462

Foremans desk



- Type**
- Robust and durable construction made of steel
 - All edges machined in a clean and safe manner
 - Off-floor drawer units
 - Easy running drawers thanks to high-quality roller guides, 50 kg load capacity, min. 85 % extension, centralised locking with cylinder lock
 - Large area workplace, 25 mm thick, light grey, melamin resin hardened
 - Feet with height adjustment for uneven floors
 - High-quality powder coating in RAL 7035, light grey
 - TÜV/GS tested and 100 % Made in Germany

82462 101



82462 102



Number of drawers x Front height mm	Table thickness mm	82462	...
1x75 / 1x125 / 1x150 / 2x175 / 1x300	1700 x 800 x 25	F #	101
1x150 / 2x175	1700 x 800 x 25	F #	102

Facility Equipment

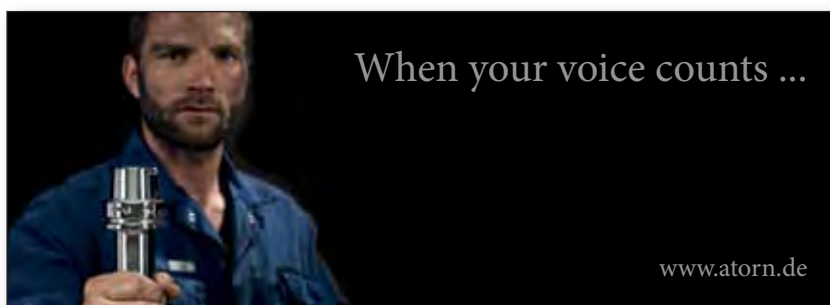

When your voice counts ...

www.atorn.de

... your suggestions are heard.

ATORN®
Performance requires quality

Info

Company equipment for high demands:

We offer customised workshop furnishings for: industry, trade, training workshops, workshops for the handicapped, universities, vocational schools.

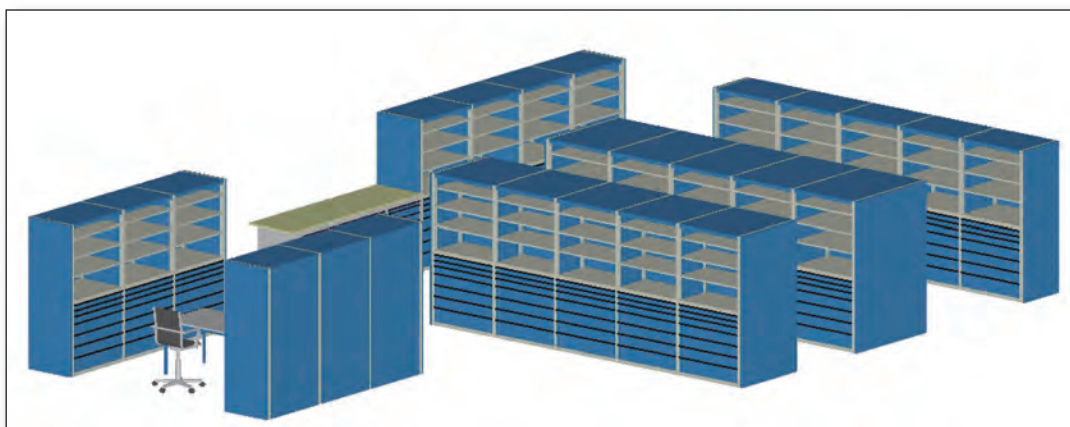
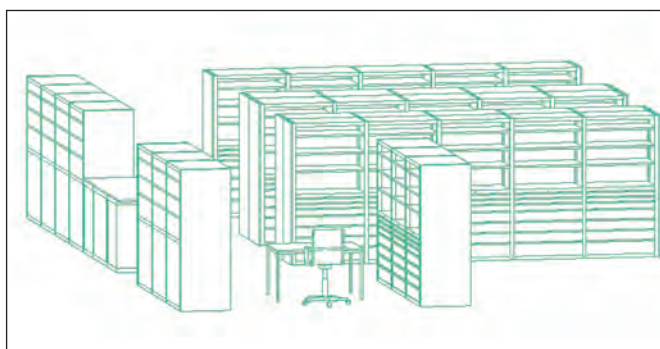
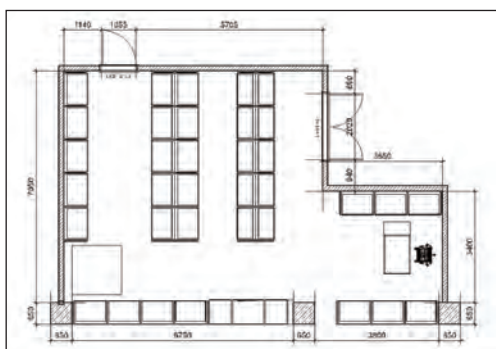
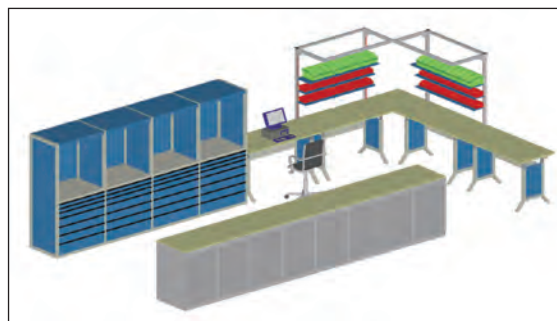
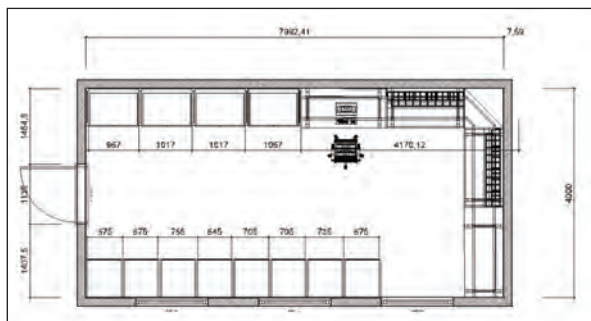

With us, you get everything from one source. We can use CAD software to plan your workshop and to customise it according to your needs and requirements. We are here to assist you.

Info

For more detailed information on partition walls and organisation or filing systems, please ask for our catalogue, order number 00 080 235!

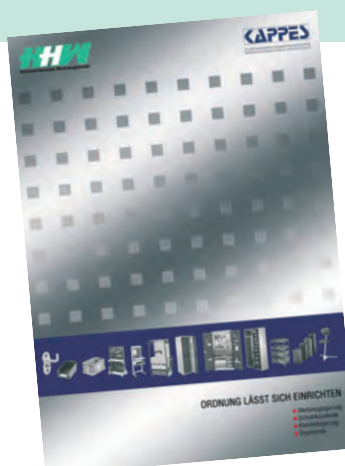

KAPPES**Type**

- The systematic path to organisation with RasterPlan perforated panels
- Clearly arranged tool storage
- Quick access
- Systemised and colour-coded organisation
- Impact and scratch-resistant plastic coating
- Especially shaped beams
- Sheet steel 1.25 mm
- Concealed screw holes
- 5 brilliant colours
- 4 dimensions, 8 different applications
- Compatible to RasterPlan perforated panels
- Delivery without toolholder

Use

Can be used in many different ways, from the single perforated panel on the wall to partition walls, trolleys, to tool cabinets with retractable panels.

Note:

Tool holder, see cat.-no. 82471-82480.

82465

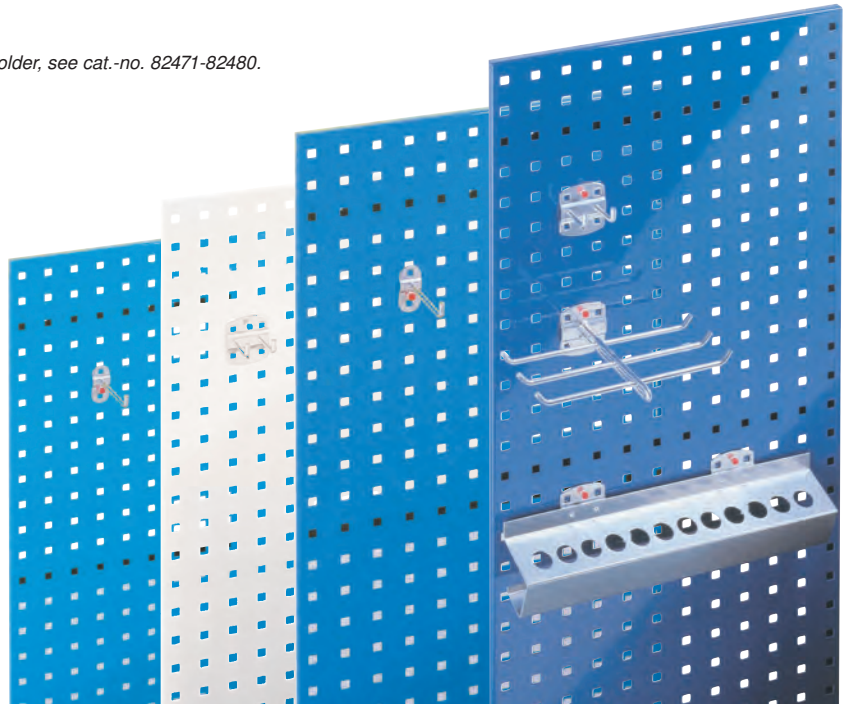
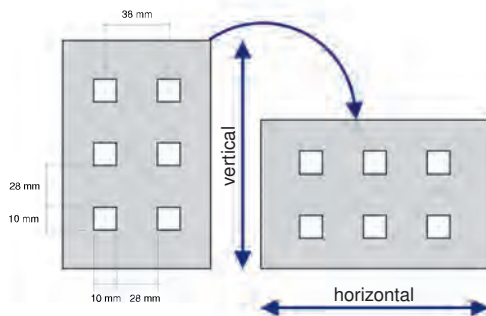

Dimensions W x H mm	500 x 450	1000 x 450	1500 x 450	2000 x 450
Plate colour	82465	...	82465	...
RAL 5012 light blue	# 310	# 401	# 501	# 701
RAL 5015 sky blue	# 311	# 402	# 502	# 702
RAL 5010 gentian blue	# 312	# 403	# 503	# 703
RAL 7035 light grey	# 306	# 406	# 506	# 706

KAPPES**Type**

The perfect tool holder for each tool, plastic laminated, colour aluminium. The brackets simply have to be hung in the desired hole and to be fixated with a small plastic screw.

82471 100



82471 101

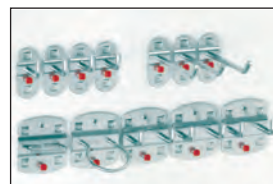

82471 102



Tool holder Assortments	82471	...
10-part	# 100	
12-part	# 101	
15-part	# 102	
18-part	# 103	
28-part	# 104	
40-part	# 105	

82471 103

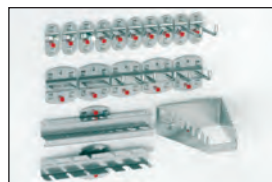

82471 104

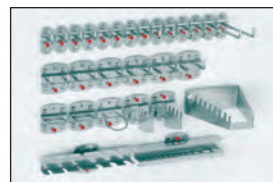

82471 105

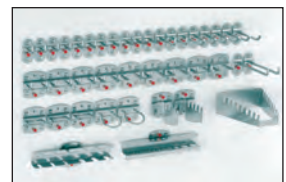

www.atorn.de

Performance requires quality.

For example, with the UNICHECK universal measuring device from ATORN.

- For a wide variety of measuring tasks
- Flexible implementation thanks to different measurement attachments
- Robust construction
- Complete range of extension accessories

ATORN®
Performance requires quality.



Tool holders

82480

Tool holder for perforated panels

KAPPES

Type

- Tool holders create order and organisation.
- Impact and scratch-resistant plastic coating colour, aluminium colour
- Stamped base plate 1,5 mm thick
- Incl. of RasterPlan plastic screw



82480 101-104

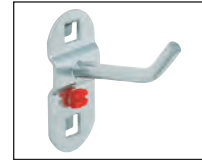

82480 105-107



82480 108-111



82480 112-116



82480 117-121

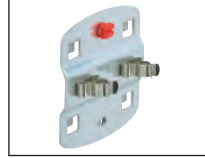

82480 122-124



82480 125-127

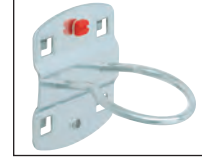

82480 128



82480 129



82480 130



82480 131



82480 132-133

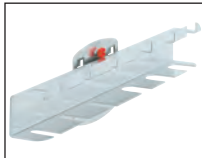

82480 134-135

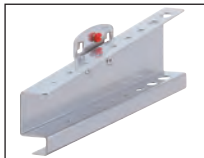

82480 136

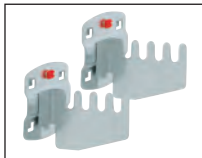

82480 137



82480 138

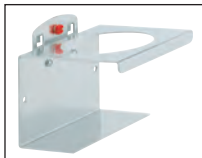

82480 173

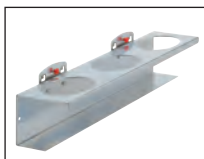

82480 139

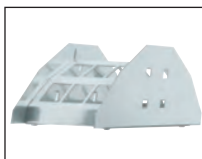

82480 140-141

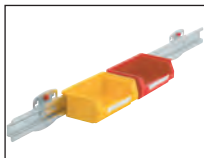

82480 142



82480 143



82480 144

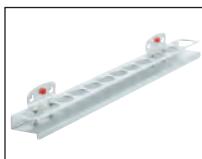

82480 150

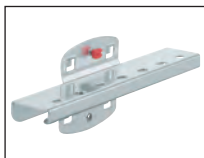

82480 151

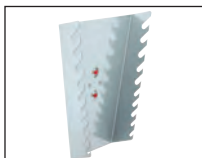

	Size mm	Ø mm	Pack = pcs.	82480	
Tool holder with slanted hook end	50	6	5	#	101
Tool holder with slanted hook end	100	6	5	#	102
Tool holder with slanted hook end	150	6	5	#	103
Tool holder with slanted hook end	200	6	5	#	104
Tool holder with vertical hook end	35	6	5	#	105
Tool holder with vertical hook end	75	6	5	#	106
Tool holder with vertical hook end	125	6	5	#	107
Tool holder double	35 x 35	6	5	#	108
Tool holder double	50 x 35	6	5	#	109
Tool holder double	75 x 35	6	5	#	110
Tool holder double	150 x 35	6	5	#	111
Tool clamp single	-	6	5	#	112
Tool clamp single	-	10	5	#	113
Tool clamp single	-	13	5	#	114
Tool clamp single	-	16	5	#	115
Tool clamp single	-	19	5	#	116
Tool clamp double	-	6	5	#	117
Tool clamp double	-	10	5	#	118
Tool clamp double	-	13	5	#	119
Tool clamp double	-	16	5	#	120
Tool clamp double	-	19	5	#	121
Pliers holder	35 x 20	-	5	#	122
Pliers holder	55 x 20	-	5	#	123
Pliers holder	75 x 20	-	5	#	124
Power tool holder	-	40	1	#	125
Power tool holder	-	60	1	#	126
Power tool holder	-	80	1	#	127
Tool holder 3-part	150 x 45	-	1	#	128
Tool holder 6-part	140 x 240	-	1	#	129
Combination tool holder 2-part	150 x 55	-	1	#	130
Wrench holder, horizontal	for 8 wrenches	-	1	#	131
Screwdriver holder	for 6 screwdrivers	-	1	#	132
Screwdriver holder	for 12 screwdrivers	-	1	#	133
Twist drill holder	for 14 drills	-	1	#	134
Twist drill holder	for 28 drills	-	1	#	135
Saw holder	for 4 saws	-	2	#	136
Storage plate	350 x 125	-	1	#	137
Round can holder 1-x	100	70	1	#	138
Round can holder 3-x	300	70	1	#	173
Hose holder	230 x 125	-	1	#	139
Storage box holder 5-x for size 7	550 x 58	-	1	#	140
Storage box holder 5-x for size 8	550 x 38	-	1	#	141
Customisable tool holder	120 x 45	-	1	#	142
Customisable tool holder	390 x 45	-	1	#	143
Socket tray 12 openings	390 x 30	-	1	#	144
Bit holder 7-part	150 x 35	-	1	#	150
Ring spanner holder, vertical	for 10 spanners	-	1	#	151
Wrench holder, vertical	for 10 wrenches	-	1	#	152
Leaflet clip DIN A4, RAL 7035 light grey	220 x 310	-	1	#	160
Leaflet clip DIN A3, RAL 7035 light grey	440 x 310	-	1	#	174

Facility Equipment





	Size mm	Ø mm	Pack= pcs.	82480	...
Form sheet clip DIN A4, RAL 7035 light grey	220 x 310	-	1	#	165
Spare screw	-	-	100	#	166
Paper roll holders for width 295 mm	355 x 120	-	1	#	171
Tool holder with straight arbor single	50	6	5	#	175
Tool holder with straight arbor single	100	6	5	#	176
Tool holder with straight arbor single	150	6	5	#	177
Tool holder with straight arbor double	50	6	5	#	178
Tool holder with straight arbor double	100	6	5	#	179
Tool holder with straight arbor double	150	6	5	#	180
Magnetic holder	-	40	1	#	181
Slanted hooks for socket wrench and screwdriver bits	14 / 40	6	1	#	182
Customisable base plate	small	-	1	#	183
Customisable base plate	large	-	1	#	184
Round holder	65 x 25	-	1	#	185
Pipe holder	35	60	1	#	186
Pipe holder	35	100	1	#	187
Tool holder SB	125 x 30	-	1	#	188
Cable holder	150 x 37	6	1	#	189
Cable holder	200 x 37	6	1	#	190
Allen key holder	for 9 keys	1 - 11	1	#	191
Tool holder for MT2	85 x 395	17	1	#	192
Tool holder for MT3	85 x 395	23	1	#	193
Storage box holder 1x	for size 7 + 8	-	1	#	194
Gripper clamp holder	55	from 19	1	#	195
Reel holder shaft 17 mm	max. 78	170	1	#	196
Arbor for oval cans	50 x 500	-	1	#	197
Tool holder with wooden plate	320 x 135 x 55	-	1	#	198
Tray	55 x 320 x 135	-	1	#	199
Roll holder for width 300 mm, core Ø min. 22 mm, RAL 7035 light grey	310 x 384	220	1	#	200
Bin liner holder clamping ring, RAL 7035 light grey	-	330	1	#	201
Grinding paper roll holder for width 300 mm, RAL 7035 light grey	370 x 320	-	1	#	172
Steel shelf with flanged edge, RAL 7035 light grey	490 x 243	-	1	#	202
Steel shelf tray, RAL 7035 light grey	435 x 250	-	1	#	203

KAPPES

Type

The systematic path to organisation with original RasterPlan slotted panels. **A basic element of the RasterPlan system.** Multi-purpose adapter, storage bins, steel shelves and many other holders can easily be attached to the slotted panels. RasterPlan slotted panels can be used in many different ways, on walls, as back walls of workbenches, in partition walls, trolleys, even in cabinets. And everything is provided by a single system.

- Clearly arranged tool storage
- Quick access
- Systemised and colour-coded organisation
- For HHW storage bins size 5 - 8
- Impact and scratch-resistant plastic coating
- Especially shaped beams
- Sheet steel 1.25 mm
- Concealed screw holes
- 4 brilliant colours
- 7 dimensions, 7 different applications
- Compatible to RasterPlan perforated panels

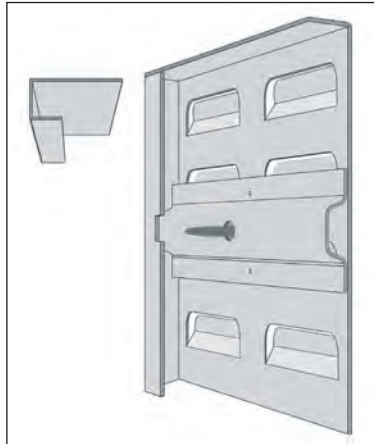

Design on the reverse side:
RasterPlan slotted panels are reinforced on the reverse side by means of special beams, doubly spot-welded, for highest load.

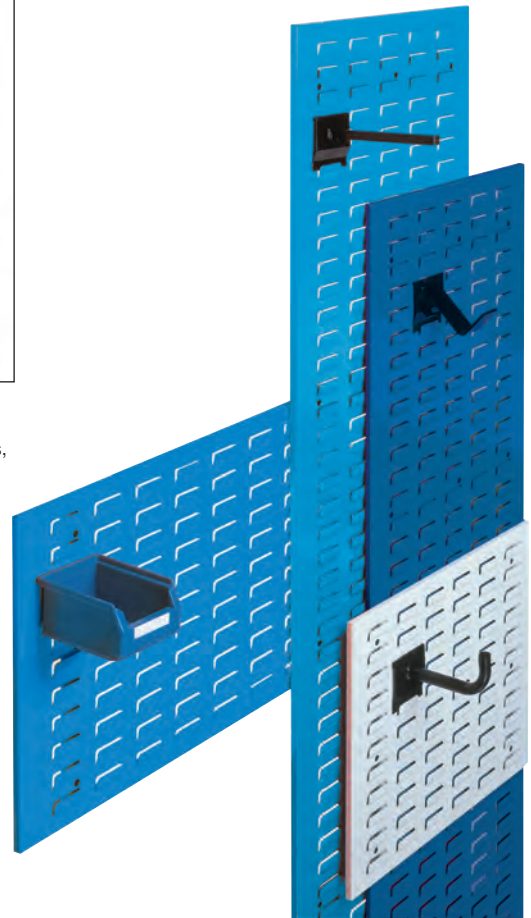

82482

82482 201-406

Type

Wide version.

82482 501-806

Type

Upright version.

Dimensions W x H mm	500x450		1000x450		1500x450		2000x450		450x1000		450x1500		450x2000	
Colour RAL	82482	...	82482	...	82482	...	82482	...	82482	...	82482	...	82482	...
5012 light blue	#	301	#	401	#	201	#	210	#	801	#	501	#	701
5015 sky blue	#	302	#	402	#	202	#	211	#	802	#	502	#	702
5010 gentian blue	#	303	#	403	#	203	#	212	#	803	#	503	#	703
7035 light grey	#	306	#	406	#	206	#	215	#	806	#	506	#	706

Info

Stacking bins for slotted panels



The special design of the rail enables the user to remove and replace the storage bins horizontally, be they full or empty. No more spilling the contents.

Stacking bins, see catalogue pages 83.1 and 83.2.



horizontal

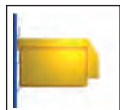

vertical



snap in place and finished

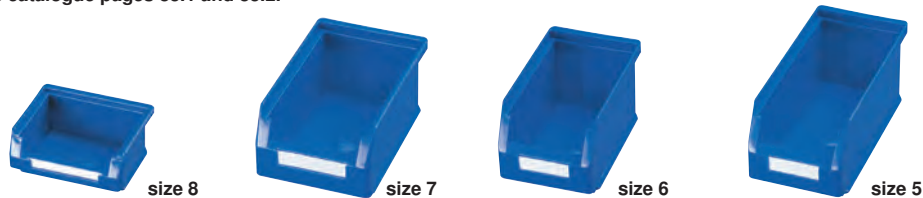

Size	Length x Width x Height approx. mm	Red		Blue		Grey		Green		yellow		ESD	
		83401	...	83402	...	83403	...	83404	...	83405	...	83412	...
8	85 x 105 x 45	101		101		101		101		101			
7	160 x 105 x 75	102		102		102		102		102		102	
6	230 x 140 x 130	103		103		103		103		103		103	103
5	290 x 140 x 130	104		104		104		104		104		104	



KAPPES

Use

For hanging into the slotted panel of RasterPlan system. Multi-purpose adapter, storage bins, steel shelves and many other holders can easily be attached to the slotted panels. Robust and sturdy, made for long service life in the industry.

- shock and scratch-proof plastic coating
- stamped base plate 1,5 mm thick
- high load capacity



82485 101-102

82485 103-104

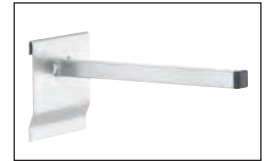
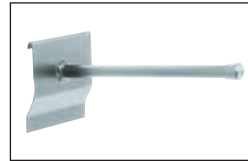

82485 105

82485 106

82485 107

82485 108

82485 109

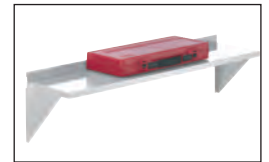
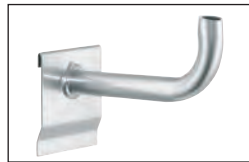
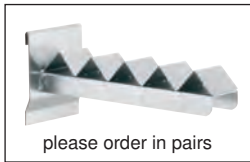

82485 113

82485 114

82485 115

82485 116

82485 117

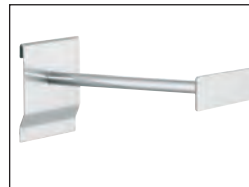

	Size mm	Ø mm	Pack= pcs.	82485	...
Multi-purpose adapter round load capacity 10 kg	200	12	1	#	101
Multi-purpose adapter round load capacity 10 kg	300	12	1	#	102
Multi-purpose adapter square-end load capacity 17 kg	200	15 x 15	1	#	103
Multi-purpose adapter square-end load capacity 17 kg	300	15 x 15	1	#	104
Shaft holder shaft distance 55 mm load capacity 17 kg	200	-	1	#	105
Plug holder load capacity 17 kg	140 x 60	-	1	#	106
Pipe holder load capacity 17 kg	160	20	1	#	107
Steel shelf RAL RAL 7035	500 x 250	-	1	#	108
Steel shelf RAL RAL 7035	1000 x 250	-	1	#	109
Base plate with lettering area	-	-	1	#	113
Adapter for perforated panel tool holder	-	-	1	#	114
Multi-purpose tool holder with lettering area load capacity 10 kg	200	12	1	#	115
Form sheet clip DIN A4, RAL 7035 light grey	-	-	1	#	116
Leaflet clip DIN A4, RAL 7035 light grey	-	-	1	#	117
Leaflet clip DIN A3, RAL 7035 light grey	-	-	1	#	118

82485 118



KAPPES

Type

Ready to use starter packages assists you in your initial decisions to create order and keep it that way.

Note:

Storage bins sorted according to colour, ex-stocks, colours not binding.

82470 101+201

Type

Comprising:

- 1 slotted panel H 450 x W 1000 mm
- 6 stacking bins size 6
- 16 stacking bins size 7
- 8 stacking bins size 8

82470 102+202

Type

Comprising:

- 1 slotted panel H 450 x W 500 mm
- 8 stacking bins size 7
- 12 stacking bins size 8

82470 101+201



82470 102+202



Dimensions H x W mm	Colour	82470	...
450 x 1000	RAL 7035 light grey	#	101
450 x 1000	RAL 5012 light blue	#	201
450 x 500	RAL 7035 light grey	#	102
450 x 500	RAL 5012 light blue	#	202

82470

RasterPlan combination plates

RasterPlan
von Kappes



KAPPES

Type

2/3 perforated and 1/3 slotted panel.

Note:

Extensive perforated and slotted panel accessories see cat.-no. 82471, 82480, 82485, and 82467.

82470 403+401

Starter sets

Comprising:

- 1 combination panel
- 12 stacking bins size 7
- 4 stacking bins size 8
- 1 tool holder assortment 10-part

82470 301

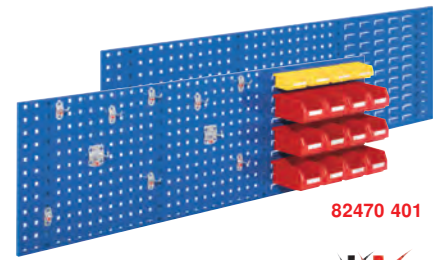

82470 401

Dimensions H x W mm	Panel colour	Not equipped		Starter set	
		82470	...	82470	...
450 x 1500	RAL 7035 light grey	#	303	#	403
450 x 1500	RAL 5012 light blue	#	301	#	401

82467

RasterPlan workbench attachments

RasterPlan
von Kappes



KAPPES

Type

Fastening material included.

Use

For mounting at workbenches and panels above each other. 2 holding fixtures are needed for each panel. Price per item.

Workbench attachment for plates wide version	82467	...
for 1 panel	#	101
for 2 panels above each other	#	105



82467

82490

RasterPlan LogoChart storage

RasterPlan
von Kappes



KAPPES

Type

- Multifunctional and flexible
- Impact and scratch-resistant plastic coating
- Possible uses, horizontal or vertical
- H 450 x W 1000 mm, RAL 7035 light grey
- Writing area can be wiped away without trace (do not use permanent markers)
- Magnetic

Use

Innovative solutions for setting up production rooms, warehouses, goods issuing, goods-in, workshops and many other areas.

The smooth panel area is ideal for sketches, brainstorming, planning, instructing and for other visualisations direct at your workplaces.

Unique combination of proven and tested whiteboard and perforated panel that are adapted seamlessly into existing RasterPlan systems.

Note:

Wide range of perforated panel accessories, see cat.-no. 82471 and 82480.



82490 101

82490 102

82490 103

	82490 101 Set 1	82490 102 Set 2	82490 103 Set 3
1 LogoChart	x	x	x
2 double tool holder	x	x	x
2 tool holder, slanted edge	x	x	x
2 tool clamps	x	x	x
1 magnet holder	x	-	-
1 combination holder	x	x	x
1 storage shelf	x	-	-
1 document box	-	x	-
1 roll holder	-	-	x
5 magnets	x	x	x
1 wiper, magnetic	x	x	x
1 cleaning spray	x	x	x
2 non-permanent pens, black	x	x	x

82490 201

82490 202



82490 203

82490 204

LogoChart Storage	82490	...
Set 1	#	101
Set 2	#	102
Set 3	#	103

		Accessories				
	Width mm	Height x Depth mm	Ø mm	Colour	82490	...
Spray can holder	76	-	1 x 52	aluminium coloured	#	201
Pin holder	112	-	4 x 17	aluminium coloured	#	202
Combined holder for pens and spray cans	176	-	4 x 17 / 1 x 52	aluminium coloured	#	203
Storage box	250	35 x 80	-	aluminium coloured	#	204

82486 - 82487

RasterPlan wall rails (empty)

RasterPlan
von Kappes



KAPPES

Note:

Extensive perforated and slotted panel accessories see cat.-no. 82471, 82480, 82485, and 82467.

Dimensions length x height mm	Colour	Perforated panel		Slotted panel	
		82486	...	82487	...
460 x 70	RAL 7035 light grey	#	101		
920 x 70	RAL 7035 light grey	#	201		
460 x 100	RAL 7035 light grey			#	101
460 x 100	RAL 5012 light blue			#	102
920 x 100	RAL 7035 light grey			#	201
920 x 100	RAL 5012 light blue			#	202

82486 201

82487 102

82487 201

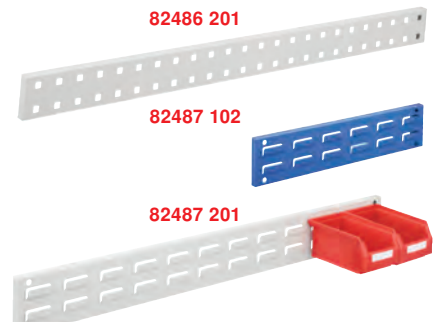

KAPPES

Separating workplaces, partition or organising rooms, whatever the purpose, the RasterPlan Partition Wall System is the solution.

Individual elements as well as pre-fabricated customised solutions for partition walls and other applications.

Please send us your enquiry.

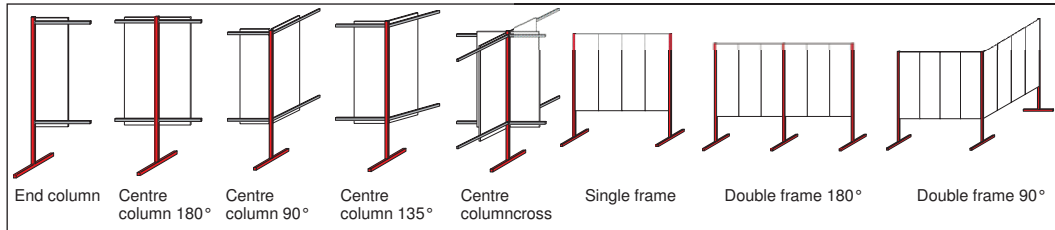

KAPPES

These partition walls which can be equipped with RasterPlan perforated panels, slotted panels or both, are intended for workplaces, where both tools and small parts, such as screws have to be in reach.

- modular design with 4 different heights
- alterations such as exchanging slotted or perforated panels is possible any time
- shock and scratch-proof plastic coating
- Frame light grey RAL 7035 / panels light blue RAL 5012
- available as single and double-sided version

dimensions of partition walls

Width x Depth 1000 x 240 mm (double-sided depth 430 mm)

Height:

- size 2 = 760 mm
- size 3 = 1100 mm
- size 4 = 1450 mm
- size 5 = 1790 mm



RasterPlan partition walls are fitted for mounting on the floor with concealed screw holes.



size 2 with fittings SW-B

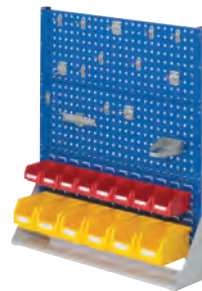

size 3 with fittings SW-C

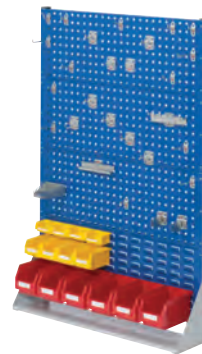

size 4 with fittings SW-E



size 5 with fittings SW-G

Fittings partition walls			
for size 2	for size 3	for size 4	for size 5
Fittings SW-A	Fittings SW-C	Fittings SW-E	Fittings SW-G
1 toolholder assortment 12-part	1 toolholder assortment 15-part	1 toolholder assortment 28-part	1 toolholder assortment 40-part
	6 stacking bins size 6	6 stacking bins size 6	1 form sheet clip
	8 stacking bins size 7	4 stacking bins size 7	1 Shelf 1000 mm
		4 stacking bins size 8	2 Plug holders
			1 Pipe holder
			1 multi-purpose adapter square
			9 stacking bins size 7
Fittings SW-B	Fittings SW-D	Fittings SW-F	Fittings SW-H
1 toolholder assortment 10-part	1 toolholder assortment 10-part	1 toolholder assortment 28-part	1 toolholder assortment 40-part
3 stacking bins size 7	1 Shelf 500 mm	1 Shelf 500 mm	6 stacking bins size 6
4 stacking bins size 8	2 Plug holders	2 Plug holders	8 stacking bins size 7
	4 stacking bins size 6	4 stacking bins size 6	8 stacking bins size 7
	2 stacking bins size 7	2 stacking bins size 7	
	2 stacking bins size 8		

Info

RasterMobil workshop trolley with perforated or slotted panels

KAPPES

Mobile storage for material and tools in workshop, production and assembly hall.

- modular design with 3 different heights
- alterations such as exchanging slotted or perforated panels is possible any time
- shock and scratch-proof plastic coating
- wheel module light grey RAL 7035 / panels light blue RAL 5012
- slotted or perforated panels on both sides
- ergonomic handles

Dimensions workshop trolley
 Width x Depth 1000 x 500 mm
 Height:
 size 2 = 890 mm
 size 3 = 1230 mm
 size 4 = 1580 mm

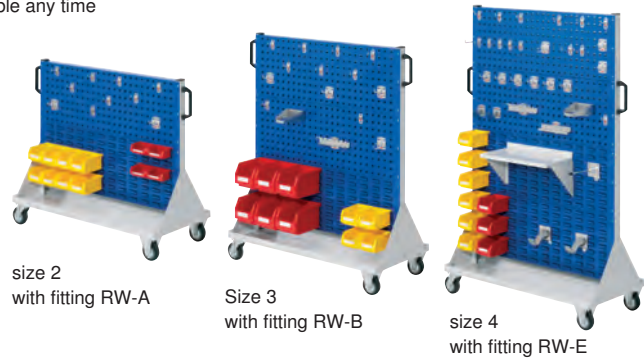

size 2 with fitting RW-A

Size 3 with fitting RW-B

size 4 with fitting RW-E

Fittings Workshop trolleys		
size 2	size 3	size 4
Fitting RW-A	Fitting RW-B	Fitting RW-E
1 toolholder assortment 10-part	1 toolholder assortment 15-part	1 toolholder assortment 28-part
8 stacking bins size 7	6 stacking bins size 6	1 Shelf 500 mm
4 stacking bins size 8	4 stacking bins size 7	1 Universalhalter
		2 Plug holders
		9 stacking bins size 7

Info

Shelves with Storage Bins



KAPPES

Not assembled.
 Shelves can be 300, 400 and 500 mm deep, each with 16 shelves/panels.
 Height of shelf 2000 mm, width of shelf 1000 mm. Not assembled.

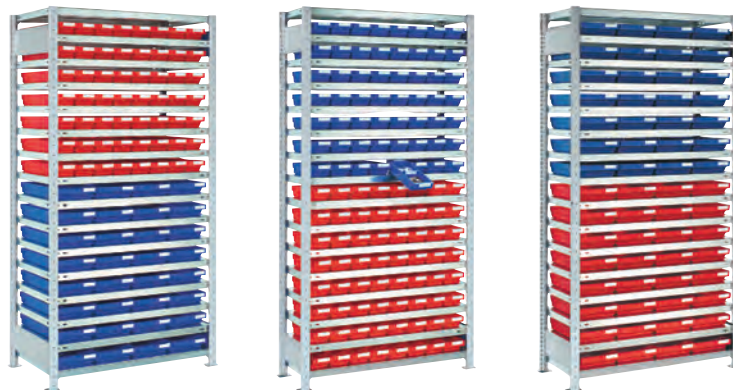

Facility Equipment

82510 - 82513

RasterPlan perforated panel tool cabinets (empty)



KAPPES

Type

Sturdy, made of sheet steel. Impact and scratch-resistant plastic coating Back wall RasterPlan hole panel. Distance piece for a secure mounting on walls. Opening angle more than 180°. Security cylinder lock.

Note:

Perforated panel accessories see cat.-no. 82471 and 82480.

82510

With doors with perforated panels.

82513

With doors with perforated panels and 2 additional inner doors.



82510



82513

Colour doors	Colour housing	Dimensions H x W x D mm	82510	...	82513	...
RAL 5012 light blue	RAL 7035 light grey	620 x 920 x 335	F #	101	F #	101
RAL 7035 light grey	RAL 7035 light grey	620 x 920 x 335	F #	102	F #	102



KAPPES

Type

Sturdy, made of sheet steel. Impact and scratch-resistant plastic coating. **Back wall RasterPlan hole panel.** Front-built doors for a smooth front, opening angle more than 200°. Continuous rodding guiding, double-walled reinforced doors. Galvanised shelves, load capacity 80 kg at equal distribution. Adjustability 10 mm grid pattern. Three-bolt security cylinder lock.

82550 604

Additional shelf

Type

Galvanised, depth 410 mm.

Use

Suitable for RasterPlan tool cabinets with doors with perforated panels (cat.-no. 82550), doors with slotted panels (cat.-no. 82552), and doors with windows (cat.-no. 82554).

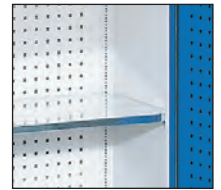

82550 604



Dimensions H x W x D mm	Number of shelf	Colour doors	Colour housing	Doors with perforated panels		Doors with slotted panels		Doors with windows	
				82550	...	82552	...	82554	...
1000 x 1000 x 410	-	RAL 5012 light blue	RAL 7035 light grey	F #	099	F #	101		
1600 x 1000 x 410	1	RAL 5012 light blue	RAL 7035 light grey	F #	100	F #	102		
1950 x 1000 x 410	2	RAL 5012 light blue	RAL 7035 light grey	F #	103	F #	103	F #	103
Additional shelf	-	-	-	#	604				

KAPPES

82555

Type

RasterPlan tool cabinets for a professional and practical storage and organisation of high-quality tools and materials, with drawers (100 mm front height) and integrated workbench (Multiplex) top (30 mm thick). We recommend fastening the tool cabinets to the wall or the floor.

H x W x D 1950 x 1000 x 600 mm.

Sturdy, made of sheet steel. Impact and scratch-resistant plastic coating. Housing light grey RAL 7035, doors light blue RAL 5012 or light grey RAL 7035. Back wall with RasterPlan hole panel and/or slot profile. Front-built doors for a smooth front, opening angle more than 200°. Continuous rodding guiding, double-walled reinforced doors. Telescope-guided drawers with 100% extension. Retrofitting is also possible. Drawer load capacity 110 kg at equal distribution. Galvanised shelves, load capacity 80 kg at equal distribution. Adjustability 25 mm grid pattern. Three-bolt security cylinder lock.

Note:

Additional drawers, shelves, and workbench top see cat.-no. 82556 599-609.

82556 599-600

Drawer

Type

100 mm front height.

82556 606-607

Drawer

Type

125 mm front height.

82556 608-609

Drawer

Type

175 mm front height.

82556 603

Storage shelf

Type

Galvanised, load capacity 80 kg at equal distribution.

82556 604

Workbench top

Type

Multiplex, 30 mm thick.



Model 1



Model 3



Model 4



Model 5

Continuation ▶

Continuation ▶

KAPPES

Model 6

Model 7



82556 599



82556 603



82556 600



82556 604

Doors with perforated panels

Model	Number of Shelves	Number of drawers	Workbench top	RAL 7035/5012 82555	...	RAL 7035 82555	...
1	3	2	-	F #	102	F #	202
3	1	4	1	F #	106	F #	206
4	2	4	-	F #	101	F #	208
5	2	3	-	F #	107	F #	209
6	2	2	1	F #	108	F #	210
7	-	9	1	F #	104	F #	204

Doors with perforated panels

Model	Number of shelves	Number of drawers	Workbench top	RAL 7035/5012 82555	...	RAL 7035 82555	...
1	3	2	-	F #	100	F #	201
3	1	4	1	F #	105	F #	205
4	2	4	-	F #	112	F #	212
5	2	3	-	F #	110	F #	213
6	2	2	1	F #	111	F #	214
7	-	9	1	F #	103	F #	219

Doors with windows

Model	Number of shelves	Number of drawers	Workbench top	RAL 7035/5012 82555	...	RAL 7035 82555	...
1	3	2	-	F #	501	F #	701
3	1	4	1	F #	502	F #	702
4	2	4	-	F #	503	F #	703
5	2	3	-	F #	504	F #	704
6	2	2	1	F #	505	F #	705
7	-	9	1	F #	506	F #	706

Accessories

	RAL 5012 82556	...	RAL 7035 82556	...	82556	...
Drawer 100 mm front height	#	600	#	599		
Drawer 125 mm front height	#	606	#	607		
Drawer 175 mm front height	#	608	#	609		
Shelf					#	603
Workbench top					#	604



www.atorn.de

Performance requires quality.

For example, with the 4-10 Power and 4-15 Power angular milling cutter from ATORN.

- Multi-function milling tool system
- 4 cutting edges on a double-sided indexable insert
- Nickel-plated
- Inner coolant feed

ATORN®
Performance requires quality.

Facility Equipment

The flexible CLIP-O-FLEX clip-in system is available separately (clip-in rails and clip-in profile), as well as with further furnishings such as shelves / drawers, or in combination with tool carts, workbenches, storage carts, etc.
Using one clipping movement, you can fix or release your work / storage area or existing organisation system.
Design your workplace ergonomically using different inclination angles 0/40/80° or 0/45/90° - or use the option for moving to the side.

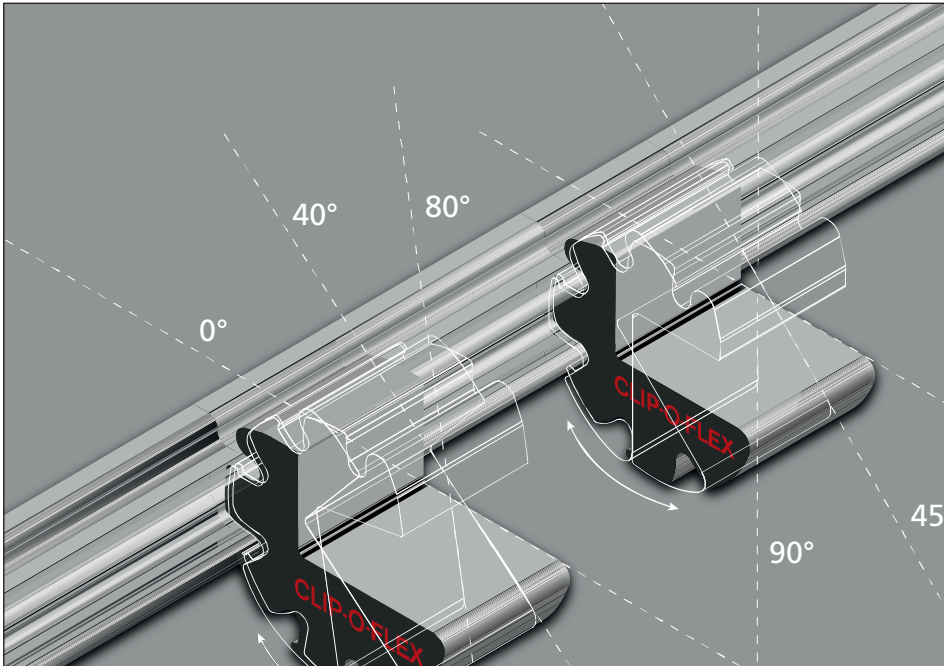

CLIP-O-FLEX fixes your working / storage area or your organisation system with the highest horizontal and vertical flexibility at the same time!

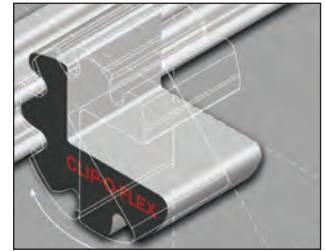

The flexible clip-in profile permits hanging-on and out at angles of 0/40/80° or 0/45/90° that can be changed at any time, and can be moved to the side.

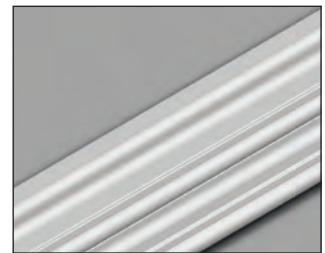

The stable clip-in rail is made of aluminium and is very light, loadable and an eye-catcher.



Option for moving to the side.



Prefabricated trays in different size, e.g., combined with a hard foam insert, or as storage area.



Order the clip-in rails and clip-in profil separately and make your own individual and flexible component, work or storage area.

The benefits of CLIP-O-FLEX!

- Quicker access to work equipment
- Flexible design of workplaces
- A high level of oversight
- Quick exchange and replacement
- Ergonomic design of workplaces
- Quick conversion
- Saves walking time
- Optimum use of working space without any loss

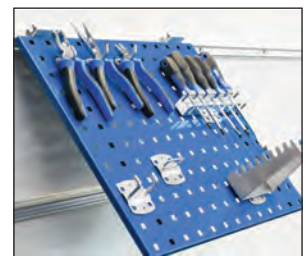

Determine the angle - one Clip your working / storage area is then secured fixiert. Possible inclination angles 0/40/80° or 0/45/90°.

Facility Equipment

Clip-in system CLIP-O-FLEX

82373

CLIP-O-FLEX clip-in rails

Type

- Overall length = Nominal length + 5 mm caps
- Pre-drilled
- The scope of supply includes end caps, incl. fastening material

Use

For fixing to RasterPlan perforated panels (38 mm division), workbenches, storage carts, wall / or workbench attachments. As holder for CLIP-O-FLEX clip-in profiles and trays.

Quality

Aluminium, natural anodised finish.

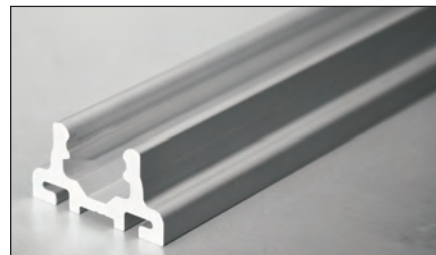

82373

Length mm	Caps colour	82373	...
495	Black		101
695	Black		102
745	Black		103

Length mm	Caps Colour	82373	...
795	black		104
985	black		105
1400	black		106

Length mm	Caps Colour	82373	...
1495	black		107
1995	black		108

82374

CLIP-O-FLEX clip-in profile

Type

- 3 x Ø 4.1mm drilled or selectively with thread M5
- Pre-drilled
- Drill template included

Use

For fastening to a CLIP-O-FLEX clip-in rails. Different materials can be screwed onto, riveted to or glued onto the clip-in profiles.

Quality

Aluminium, natural anodised finish.

Note:

Packaging unit (PU) 2 pcs.
Price per PU.



82374

Clip-in corner mm	Width mm	Caps colour	PU (pcs.)	Borehole		M5 thread	
				82374	...	82374	...
0/40/80°	50	black	2			101	301
0/45/90°	50	black	2			201	401

82375

CLIP-O-FLEX plastic corner element

Use

For attaching to clip-in rails. For connecting two clip-in rails when using at an angle of 90°, on a workbench top for example.

Quality

Plastics.

Note:

Packaging unit (PU) 4 pcs.
Price per PU.



82375

Colour	PU (pcs.)	82375	...
black	4		101

82376

CLIP-O-FLEX plastic caps

Type

- With engaging mechanism

Use

For attaching to clip-in rails.

Quality

Plastics.

Note:

Packaging unit (PU) 10 pcs.
Price per PU.

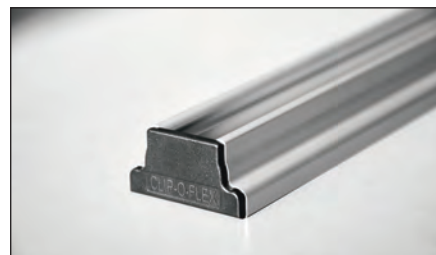

82376

Dimensions mm	Colour	PU (pcs)	82376	...
2,5	black	10		101

Facility Equipment

82377

CLIP-O-FLEX trays

NEW

82377

Type

- Incl. 2 clip-in profiles 0/40/80° or 0/45/90°
- Powder coated RAL 9006 white aluminium

Use

For clipping into CLIP-O-FLEX clip-in rails at different angles. For mobile use and for designing workplaces in a flexible manner.

Quality

Sheet steel.

Note:

The trays can be combined with OPT-I-STORE hard foam inserts (see cat.-no. 59603 - 59692).



L x W x H mm	Matching TCS insert size	0/40/80°		0/45/90°	
		82377	...	82377	...
345 x 260 x 30	1/2		101		
345 x 260 x 30	1/2				201
260 x 345 x 30	1/2		102		
260 x 345 x 30	1/2				202
520 x 345 x 30	2/2		103		
520 x 345 x 30	2/2				203

82378

CLIP-O-FLEX workbenches

NEW

82378

Type

Workbench consists of:

- Multiplex panels
- Cabinets
- Foot support
- Workbench body (only end no. 102, 103, 202 and 203)

Multiplex panels

- Painted 40 x 1500 x 750 mm
- Right side, left side and front with CLIP-O-FLEX clip-in rails screwed on

Cabinet

- 2 x drawers with full extension, front height 90 mm, load capacity 35 kg
- 6 x square shaped trays, each with 2 CLIP-O-FLEX clip-in profiles 0/40/80°
- 1 x door H = 540 mm, left side, closed
- Cabinet lockable via centralised locking
- Housing colour: RAL 9006 white aluminium
- Drawers / front colour: RAL 9005 jet black
- H x W x D = 840 x 1,500 x 750 mm

Foot support

- 1 x Footsupport H x D = 800 x 680 mm
- Made of stable U-sectional steel profile
- 80 x 50 x 2.0 mm with cross-bracing
- Foot support without level adjustment
- 1 x trim with cross-brace

82378 101-103

Type

- 6 pairs of fixed mounting brackets for CLIP-O-FLEX trays

82378 201-203

Type

- 6 pairs of extension system for CLIP-O-FLEX trays

With fixed mounting bracket



The trays can simply be placed onto the mounting bracket.

Extension system



The comfortable extensions allows the trays to be easily removed and inserted by also pulling out the rails.



Facility Equipment



The base cabinet is equipped with 6 CLIP-O-FLEX trays. These can be easily removed and after being used, can be stored back into the base cabinet clearly arranged and orderly.



Trays can be attached at all positions on the sides of the workbench. Tools and material do not need any more space on the workbench.

Workbench body height mm	Workbench body	Fixed mounting brackets for trays		Extensions for trays	
		82378	...	82378	...
-	Without	F #	101	F #	201
-	Without			F #	202
470	Included	F #	102	F #	203
470	Included			F #	203
820	Included	F #	103		
820	Included			F #	203

Clip-in system CLIP-O-FLEX

82379

CLIP-O-FLEX mobile container

Type

- Right side and left side on the cover, with CLIP-O-FLEX clip-in rails screwed on
- Incl. of 30 mm Multiplex panel painted
- 1 x Steering castor with stop
- 1 x steering castor without stop
- 2 x support castors Ø 125 mm
- Housing colour: RAL 9006 white aluminium
- Drawers / front colour: RAL 9005 jet black

Cabinet equipped with:

- 6 x square shaped trays, each with 2 CLIP-O-FLEX clip-in profiles 0/40/80°
- 1 x door, right side, closed
- Cabinet lockable via centralised locking

82379 101

Type

- 6 pairs of fixed mounting brackets for CLIP-O-FLEX trays

82379 201

Type

- 6 pairs of extension systems for CLIP-O-FLEX trays

Fixed mounting bracket



The trays can simply be placed onto the mounting bracket.

Extension systems



The comfortable extension allows the trays to be easily removed and inserted by also pulling out the rails.

NEW

82379



Incl. 6 trays each with 2 CLIP-O-FLEX clip-in profiles 0/40/80°

H x W x D mm	Trays W x D x H mm	Door height mm	Weight kg	Fixed mounting brackets for trays		Extensions for trays	
				82379	...	82379	...
778 x 474 x 405	345 x 260 x 30	540	50	F #	101		
778 x 474 x 405	345 x 260 x 30	540	59			F #	201

82380

CLIP-O-FLEX assembly tool cart

Type

- Right side and left side on the cover, with CLIP-O-FLEX clip-in rails screwed on
- Incl. of 30 mm Multiplex panel painted
- 1 x steering castor with stop
- 1 x steering castor without stop
- 2 x support castors Ø 125 mm
- Housing colour: RAL 9006 white aluminium
- Drawers / front colour: RAL 9006 jet black

Fixed mounting bracket



The trays can simply be placed onto the mounting bracket.

Extension system



The comfortable extensions allows the trays to be easily removed and inserted by also pulling out the rails.

82380 101+201

Cabinet equipped with:

- 2 x drawers with full extension
- 6 x square shaped trays, each with 2 CLIP-O-FLEX clip-in profiles 0/40/80°
- 1 x door, right side, closed
- Cabinet lockable via centralised locking

82380 101

Type

- 6 pairs of fixed mounting brackets for CLIP-O-FLEX trays

82380 201

Type

- 6 pairs of extension systems for CLIP-O-FLEX trays

82380 101+201



2 drawers with full extension, front height 90 mm, load capacity 35 kg
6 trays each with 2 CLIP-O-FLEX clip-in profiles 0/40/80°

NEW

82380 102+202

NEW



Incl. 8 trays each with 2 CLIP-O-FLEX clip-in rails 0/40/80°

H x W x D mm	Trays W x D x H mm	Door height mm	Drawer front height mm	Drawer load capacity kg	Weight kg	Fixed mounting brackets for trays		Extensions for trays	
						82380	...	82380	...
958 x 474 x 405	345 x 260 x 30	540	90	35	69	F #	101		
958 x 474 x 405	345 x 260 x 30	540	90	35	78			F #	201
958 x 474 x 405	345 x 260 x 30	720	-	-	62	F #	102		
958 x 474 x 405	345 x 260 x 30	720	-	-	71			F #	202

82381

CLIP-O-FLEX mobile tool carts

NEW

82381

Type

- Right side and left side on the cover, with CLIP-O-FLEX clip-in rails screwed on
- Incl. of 30 mm Multiplex panel painted
- 1 x Steering castor with stop
- 1 x steering castor without stop
- 2 x support castors Ø 125 mm
- Housing colour: RAL 9006 white aluminium
- Drawers / front colour: RAL 9005 jet black

82381 142

Type

- 12 pairs of fixed mounting brackets for CLIP-O-FLEX trays

82381 143

Type

- 12 pairs of extension systems for CLIP-O-FLEX trays

Left cabinet equipped with:

- 2 x drawers with full extension
- 6 x square shaped trays, each with 2 CLIP-O-FLEX clip-in profiles 0/40/80°
- 1 x door, left side, closed
- Cabinet lockable via centralised locking

Right cabinet equipped with:

- 2 x drawers with full extension
- 6 x square shaped trays, each with 2 CLIP-O-FLEX clip-in profiles 0/40/80°
- 1 x door, right side, closed
- Cabinet lockable via centralised locking

Fixed mounting bracket



The trays can simply be placed onto the mounting bracket.

Extension system



The comfortable extensions allows the trays to be easily removed and inserted by also pulling out the rails.



2 drawers with full extension, front height 90 mm, load capacity 35 kg
Incl. 6 trays each with 2 CLIP-O-FLEX clip-in profiles 0/40/80°

H x W x D mm	Tablare W x D x H mm	Door height mm	Drawer front height mm	Drawer load capacity kg	Weight kg	Fixed mounting brackets for trays		Extensions for trays	
						82381	...	82381	...
958 x 474 x 405	345 x 260 x 30	540	90	35	125	F #	142	F #	143
958 x 474 x 405	345 x 260 x 30	540	90	35	136			F #	143

82382

CLIP-O-FLEX mobile tool carts

NEW

82382

Type

- Right side and left side on the cover, with CLIP-O-FLEX clip-in rails screwed on
- incl. of 30 mm Multiplex panel painted
- 1 x Steering castor with stop
- 1 x steering castor without stop
- 2 x support castors Ø 125 mm
- Housing colour: RAL 9006 white aluminium
- Drawers / front colour: RAL 9005 jet black

82382 101

Type

- 14 pairs of fixed mounting brackets for CLIP-O-FLEX trays

82382 201

Type

- 14 pairs of extension systems for CLIP-O-FLEX trays

Left cabinet equipped with:

- 2 x drawers with full extension
- 6 x square shaped trays, each with 2 CLIP-O-FLEX clip-in profiles 0/40/80°
- 1 x door H = 540 mm, left side, closed
- Cabinet lockable via centralised locking

Right cabinet equipped with:

- 8 x square shaped trays, each with 2 CLIP-O-FLEX clip-in profiles 0/40/80°
- 1 x door H = 720 mm, left side, closed
- Cabinet lockable via centralised locking

Fixed mounting bracket



The trays can simply be placed onto the mounting bracket.

Extension system



The comfortable extensions allows the trays to be easily removed and inserted by also pulling out the rails.



2 drawers with 100% extension, front height 90 mm, load capacity 35 kg
Incl. 6 trays each with 2 CLIP-O-FLEX clip-in profiles 0/40/80°
Incl. 8 trays each with 2 CLIP-O-FLEX clip-in profiles 0/40/80°

H x W x D mm	Trays W x D x H mm	Drawer front height mm	Drawer load capacity kg	Weight kg	Fixed mounting brackets for trays		Extensions for trays	
					82382	...	82382	...
958 x 474 x 405	345 x 260 x 30	90	35	119	F #	101	F #	201
958 x 474 x 405	345 x 260 x 30	90	35	129			F #	201

When you think laterally ...

... new ideas arise.

www.atorn.de

ATORN®
Performance requires quality



Our new services brand for everything to do with your tools.

The ComBee brand stands for innovation and the highest quality in the area of self-service machines. Our responsible technical consultants in our field service organisation would be pleased to advise you with regard to the versatile implementation possibilities in your company.

