

21215

Precision Short Chucks



mimatic
Tool Systems

Type

- Extremely short design
- High concentricity precision

Scope of supply:

Incl. of wrench with T-handle for high power.

Use

For clockwise and counterclockwise operation.

Note:

Draw-in bolts see cat.-no. 21733 - 21740.

Taper ST	Clamping range mm	A mm	D mm	E mm	21215	...
40	0.5 - 13	80	48.5	29		201
40	2.5 - 16	80	51.0	29		203
50	0.5 - 13	110	48.5	29		205
50	2.5 - 16	110	51.0	29		207

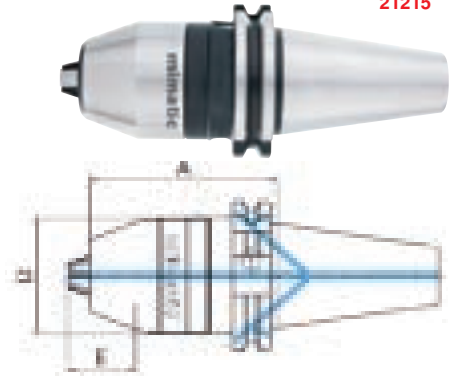

21215

21456

Quick-Change Tapping Chucks



HHW

Type

- With length compensation in response to compression and tension.

Note:

Quick-change sleeves see cat.-no. 21459 - 21460.

Draw-in bolts see cat.-no. 21733 - 21740.

Taper ST	for taps drill	Suitable inserts/size	Length compensation compr./tension mm	L mm	D mm	D2 mm	21456	...
40	M 3 - M 12	1	9.0/9.0	60	38	19		101
40	M 6 - M 20	2	15.0/15.0	100	55	31		102
40	M 14 - M 33	3	24.0/24.0	138	79	48		103
50	M 3 - M 12	1	9.0/9.0	62	38	19		104
50	M 6 - M 20	2	15.0/15.0	83	55	31		105

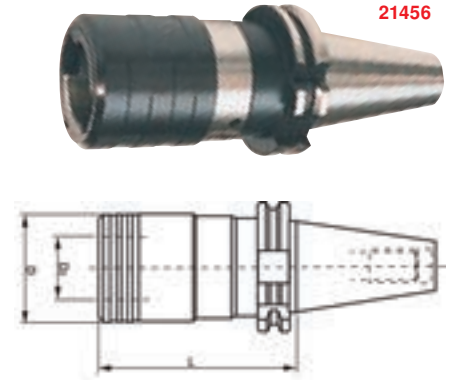

21456

21457

Quick-change tapping chuck for synchronous spindles



ATORN[®]

Type

- Minimal length compensation applied by damping element
- Safe clamping in fast-release inserts for ER collets
- Clamping screws as torsion failsafe for clamping tap drill.

Use

For use on drilling rigs and machining centres with synchronous spindles.

Warning:

The use of a synchro collet reduces high axial forces. The tap drill service life may increase by a large multiple.

Note:

Quick-change sleeves see cat.-no. 21465.

Taper SK	Size ER	d mm	D mm	A mm	Length compensation compression/traction mm	for thread-drill	21457	...
40	16	20	43	53	0.2/1.0	M 3 - M 12		101
40	25	32	60	90	0.2/1.0	M 6 - M 20		102
50	16	20	43	53	0.2/1.0	M 3 - M 12		103
50	25	32	60	74	0.2/1.0	M 6 - M 20		104

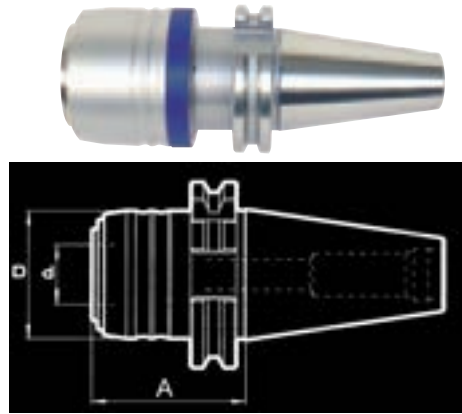

21457

21506 - 21510

ER collet chucks set



HHW

Set contents

- 1 High-performance drilling and milling chuck, type ER 40. clamping range 3 - 26 mm
- 13 Collets, type 472 E, slotted on both sides, \varnothing 4 / 5 / 6 / 8 / 10 / 12 / 14 / 16 / 18 / 20 / 22 / 24 / 25 mm
- 1 Clamping wrench

Set contents	Shank	Type	21506	...	21510	...
Clamping gripper chuck set	15-part	SK 40 in plastic crate		102		
Plastic crate	-	without content				107



21506 102

Clamping Technology