

Shanks for NC machines and machining centres

Type

Alloyed case-hardened steel, min. tensile strength 950 N/mm².
Taper angle tolerance more accurate than AT3.
Case-hardened 60-2 HRC.
Functional surfaces ground.

DIN 69871 Part 1.

- Shape A: without through-hole,
- Shape AD: with through-hole for central coolant supply,
- Shape AD/B: with through-bore for central coolant supply and 2 bores on the tool collar for lateral coolant supply,
- Shape B with 2 bores on the tool collar for lateral coolant supply.

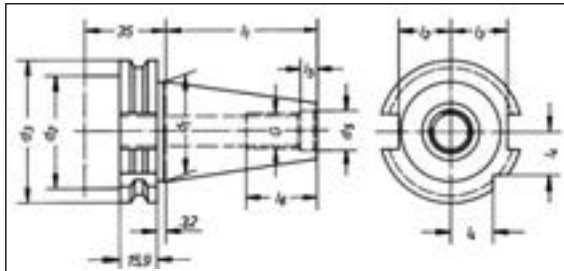

ST	d1 mm	G	d5 H7 mm	d2 max mm	d3 mm	l1 mm	l2 mm	l3 mm	l4 mm	l5 mm	l6 mm	d6 mm	e mm
30	31,75	M 12	13	45	50,00	47,80	16,4	19,0	15,0	5,5	24	4	21
40	44,45	M 16	17	50	63,55	68,40	22,8	25,0	18,5	8,2	32	4	27
50	69,85	M 24	25	80	97,50	101,75	35,5	37,7	30,0	11,5	47	6	42

21200

Precision Short Chucks



Type

- Short design
- Wearing parts hardened and ground

Scope of supply:

Incl. of wrench with T-handle for high power.

Use

For clockwise and counterclockwise operation.

Taper ST	Clamping range mm	L mm	D mm	21200	...
40	1.5 - 16	95	50	203	



21200

21185

Short chucks AKL



ALBRECHT

Präzisions Spannfutter

Type

- 100% concentricity-checked, based on DIN ISO 10888
- Worm drives for high holding forces

Scope of supply:

Incl. of wrench with T-handle for high power.

Use

For clockwise and counterclockwise operation.

Note:

Draw-in bolts see cat.-no. 21733 - 21740.
Other balancing grades available on request.
Type ULTRA with true-running accuracy less or equal to 0.015 mm available on request.

Taper ST	Clamping range mm	A mm	D1 mm	D2 mm	L1 mm	L2 mm	21185	...
40	0.5 - 10	69	38	45	78	37.5	302	
40	1.0 - 16	80	50	-	92	-	303	
50	1.0 - 16	80	50	-	92	-	304	

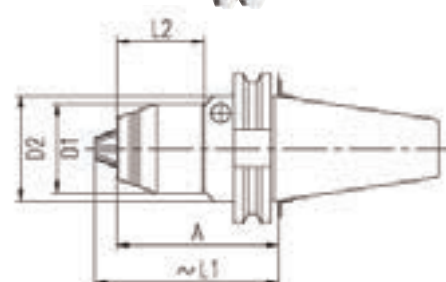

21185 302

21191

Precision Short Chucks

DIN 69871

A

G 6.3
7000
1/min



Type

- Clamping via worm drive
- Short design
- Wearing parts hardened

Scope of supply:

Incl. of wrench with T-handle for high power.

Use

For clockwise and counterclockwise operation.

Note:

Draw-in bolts see cat.-no. 21733 - 21740.

21191

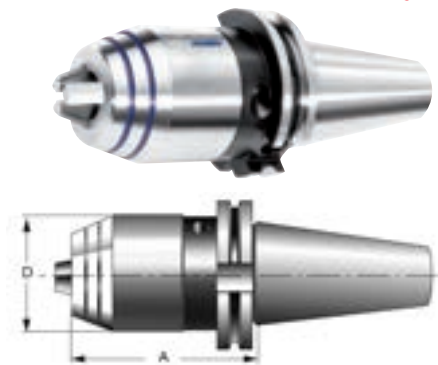

Taper	Clamping range	A	D	
ST	mm	mm	mm	
40	1 - 16	80	50	101
50	1 - 16	80	50	102 NEW

21202

Precision Short Chucks

DIN 69871

A

G 6.3
10000
1/min



Type

- Short design
- Wearing parts hardened

Scope of supply:

Incl. of wrench with T-handle for high power.

Use

For clockwise and counterclockwise operation.

Note:

Draw-in bolts see cat.-no. 21733 - 21740.

21202

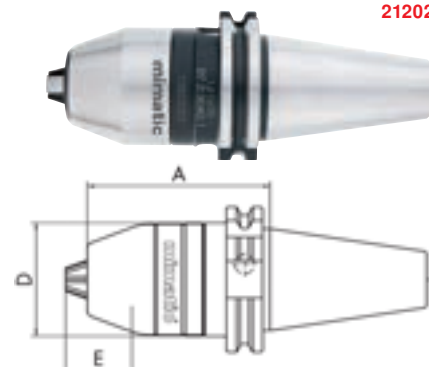

Taper	Clamping range	A	D	E	
ST	mm	mm	mm	mm	
40	0.5 - 13	80.0	48.5	29	201
40	2.5 - 16	80.0	51.0	29	202

21206

Precision Short Chucks

DIN 69871

A

G 6.3
12000
1/min



Type

- Short, stable and slim design
- High clamping forces caused by transmission ratio
- High precision and concentricity precision

Scope of supply:

Incl. of wrench with T-handle for high power.

Use

For clockwise and counterclockwise operation.

Note:

Draw-in bolts see cat.-no. 21733 - 21740.

21206



Taper	Clamping range	l ₁	d ₁	l ₂	
ST	mm	mm	mm	mm	
40	1.0 - 13	87.5	43	95.5	101
40	2.5 - 16	104.5	56	109.5	102
50	1.0 - 13	87.5	43	95.5	103
50	2.5 - 16	106.5	56	111.5	104

21212

High-performance precision short chuck

DIN 69871

A

G 6.3
10000
1/min



Type

- Extremely short design
- High concentricity precision

Scope of supply:

Incl. of wrench with T-handle for high power.

Use

For clockwise and counterclockwise operation.

Note:

Draw-in bolts see cat.-no. 21733 - 21740.

21212

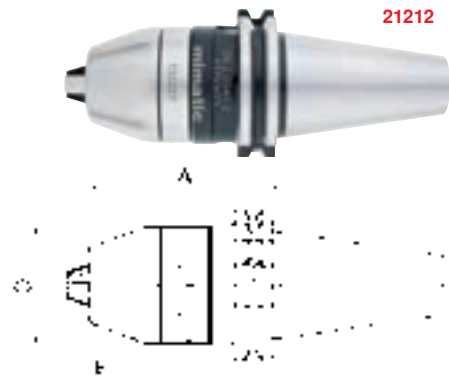

Taper	Clamping range	A	D	E	
ST	mm	mm	mm	mm	
40	0.5 - 13	80	49.5	29	101
40	2.5 - 16	80	52.0	29	102

21215

Precision Short Chucks



mimatic
Tool Systems

Type

- Extremely short design
- High concentricity precision

Scope of supply:

Incl. of wrench with T-handle for high power.

Use

For clockwise and counterclockwise operation.

Note:

Draw-in bolts see cat.-no. 21733 - 21740.

Taper ST	Clamping range mm	A mm	D mm	E mm	21215	...
40	0.5 - 13	80	48.5	29		201
40	2.5 - 16	80	51.0	29		203
50	0.5 - 13	110	48.5	29		205
50	2.5 - 16	110	51.0	29		207

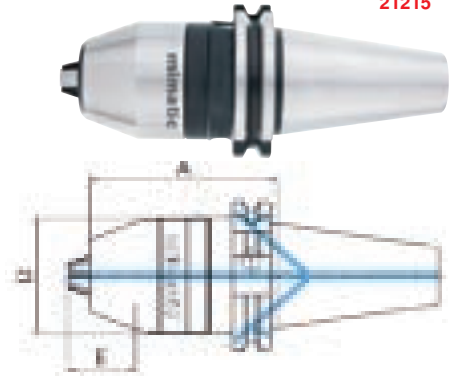

21215

21456

Quick-Change Tapping Chucks



HHW

Type

- With length compensation in response to compression and tension.

Note:

Quick-change sleeves see cat.-no. 21459 - 21460.

Draw-in bolts see cat.-no. 21733 - 21740.

Taper ST	for taps drill	Suitable inserts/size	Length compensation compr./tension mm	L mm	D mm	D2 mm	21456	...
40	M 3 - M 12	1	9.0/9.0	60	38	19		101
40	M 6 - M 20	2	15.0/15.0	100	55	31		102
40	M 14 - M 33	3	24.0/24.0	138	79	48		103
50	M 3 - M 12	1	9.0/9.0	62	38	19		104
50	M 6 - M 20	2	15.0/15.0	83	55	31		105

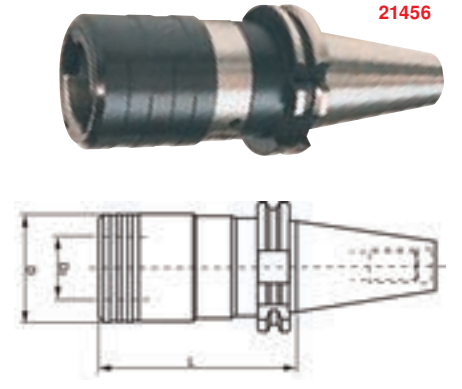

21456

21457

Quick-change tapping chuck for synchronous spindles



ATORN[®]

Type

- Minimal length compensation applied by damping element
- Safe clamping in fast-release inserts for ER collets
- Clamping screws as torsion failsafe for clamping tap drill.

Use

For use on drilling rigs and machining centres with synchronous spindles.

Warning:

The use of a synchro collet reduces high axial forces. The tap drill service life may increase by a large multiple.

Note:

Quick-change sleeves see cat.-no. 21465.

Taper SK	Size ER	d mm	D mm	A mm	Length compensation compression/traction mm	for thread-drill	21457	...
40	16	20	43	53	0.2/1.0	M 3 - M 12		101
40	25	32	60	90	0.2/1.0	M 6 - M 20		102
50	16	20	43	53	0.2/1.0	M 3 - M 12		103
50	25	32	60	74	0.2/1.0	M 6 - M 20		104

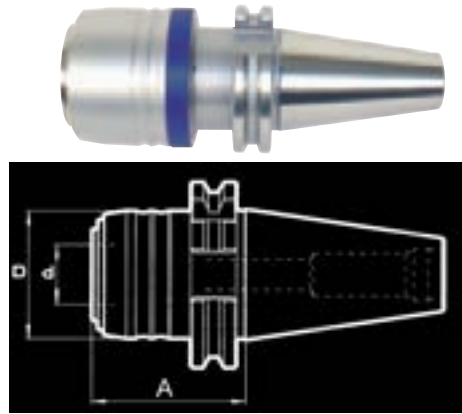

21457

21506 - 21510

ER collet chucks set



HHW

Set contents

- 1 High-performance drilling and milling chuck, type ER 40. clamping range 3 - 26 mm
- 13 Collets, type 472 E, slotted on both sides, \varnothing 4 / 5 / 6 / 8 / 10 / 12 / 14 / 16 / 18 / 20 / 22 / 24 / 25 mm
- 1 Clamping wrench

Set contents	Shank	Type	21506	...	21510	...
Clamping gripper chuck set	15-part	SK 40 in plastic crate		102		
Plastic crate	-	without content				107





21506 102

Clamping Technology

Collet chucks | Chuck extensions

21512 ER collet chucks

DIN 69871
AD

G 2.5 25000 1/min
G 6.3 15000 1/min

Type
 - Precision type.
 - Outer and inner taper ground
 - High concentricity precision



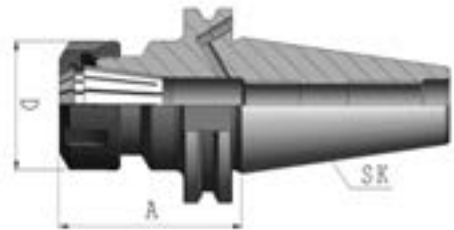









Use
 For clamping tools with straight shank in collets
 DIN 6499-shape A and B.

21512 304-320
ATORN®
Type
 - Precision-balanced G 2.5 - 25,000 rpm
 - Coated in stainless material
 - With Balluf chip bore









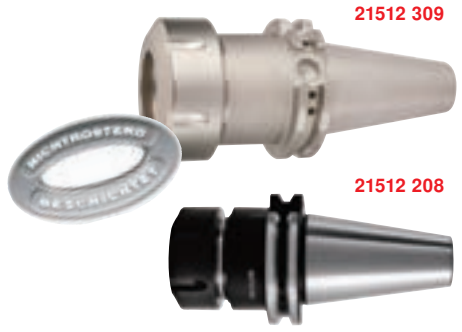





Note:
 Collet sets, see cat.-no. 21519,
 Collets see cat.-no. 21520 - 21525 and
 21534 - 21539.
 Draw-in bolt see cat.-no. 21733 - 21740.
 Clamping wrench, see cat.-no. 21532.













21512 203-227
H+W
Type
 - Balanced G 6.3 - 15,000 rpm

short					ATORN®		H+W		
Taper ST	Size	Clamping range mm	Collets type	A mm	D mm	21512	...	21512	...
30	ER 32	2 - 20	ER 32/470 E	70	50				203
40	ER 16	1 - 10	ER 16/426 E	63	32		304		204
40	ER 25	2 - 16	ER 25/430 E	60	42		307		207
40	ER 32	2 - 20	ER 32/470 E	70	50		308		208
40	ER 40	3 - 26	ER 40/472 E	80	63		309		209
50	ER 25	2 - 16	ER 25/430 E	60	42				221
50	ER 32	2 - 20	ER 32/470 E	70	50				212
50	ER 40	3 - 26	ER 40/472 E	80	63				213



medium length					ATORN®		H+W		
Taper ST	Size	Clamping range mm	Collets type	A mm	D mm	21512	...	21512	...
40	ER 16	1 - 10	ER 16/426 E	100	32		205		205
40	ER 25	2 - 16	ER 25/430 E	100	42		215		215
40	ER 32	2 - 20	ER 32/470 E	100	50		217		217
40	ER 40	3 - 26	ER 40/472 E	100	63		219		219
50	ER 16	1 - 10	ER 16/426 E	100	32				210
50	ER 25	2 - 16	ER 25/430 E	100	42				222
50	ER 32	2 - 20	ER 32/470 E	100	50				224
50	ER 40	3 - 26	ER 40/472 E	100	63				226



long					ATORN®		H+W		
Taper SK	Size	Clamping range mm	Collets type	A mm	D mm	21512	...	21512	...
40	ER 16	1 - 10	ER 16/426 E	160	32		306		206
40	ER 25	2 - 16	ER 25/430 E	160	42		316		216
40	ER 32	2 - 20	ER 32/470 E	160	50		318		218
40	ER 40	3 - 26	ER 40/472 E	160	63		312		220
50	ER 16	1 - 10	ER 16/426 E	160	32				211
50	ER 25	2 - 16	ER 25/430 E	160	42				223
50	ER 32	2 - 20	ER 32/470 E	160	50				225
50	ER 40	3 - 26	ER 40/472 E	160	63				227



21500 ER collet chucks slim

DIN 69871
AD/B

G 2.5 25000 1/min



HSC

H+W
Type
 - Clamping nut precision-balanced for HSC,
 ER11 through-bore drilled out
 - Shank hard surface-turned, with Balluf chip bore

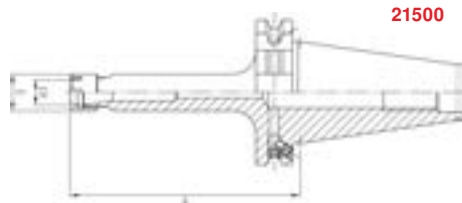

Use
 For clamping tools with straight shank in collets
 DIN 6499-shape A and B.

Note:
 Collet sets, see cat.-no. 21519,
 Collets see cat.-no. 21520 - 21525 and 21534 -
 21539. Draw-in bolts see cat.-no. 21733 - 21740.
 Collet wrench see cat.-no. 21516.

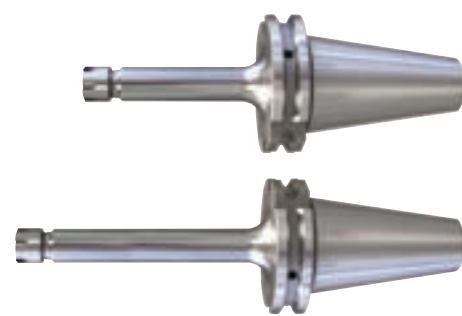

medium length							21500		...	
Taper ST	Size mm	Clamping range type	Collets mm	A mm	D mm					
40	ER 11	1 - 7	ER 11/4008 E	100	16					101
40	ER 16	1 - 10	ER 16/426 E	100	22					103
40	ER 25	1 - 16	ER 25/430 E	100	35					105



long							21500		...	
Taper ST	Size mm	Clamping range type	Collets mm	A mm	D mm					
40	ER 11	1 - 7	ER 11/4008 E	160	16					102
40	ER 16	1 - 10	ER 16/426 E	160	22					104
40	ER 25	1 - 16	ER 25/430 E	160	35					106

Clamping Technology

21515

ER chuck extensions

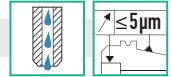

Type

- Cylindrical tool holders with Weldon shank
- Smallest dimensions

Use

Extension of Weldon mounts and/or collet chucks.

Clamping range mm	Shank Ø d mm	collets Type	L mm	D mm	21515	...
1 - 7	16	ER 11/4008 E	162	16		101
1 - 10	20	ER 16/426 E	178	22		102
1 - 13	25	ER 20/428 E	190	28		103

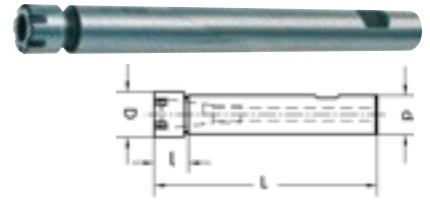

21515

21505

Precision collet



Type

- Ultra-precise, **patented** precision chuck with optimum concentricity and repeat precision
- High holding forces
- High rigidity
- Very stable
- With large tool aperture

Scope of supply:

Incl. Clamping nut.

Use

For ultra-precise clamping during roughing and finish-milling, drilling, reaming, countersinking, thread tapping etc.

Warning:

Also suitable for HPC/HSC milling up to approx. 200 °C.

Note:

Clamping wrench, see cat.-no. 21509.
 GER-HP collets see cat.-no. 21546 - 21551.
 GER-B collets see cat.-no. 21534 - 21539.
 Draw-in bolts see cat.-no. 21733 - 21740.
 Replacement clamping nut see cat.-no. 21518.

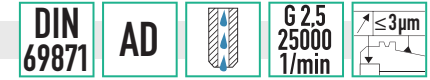

21505

Taper SK	Collets type	Clamping range mm	Dimension D mm	Dimension A mm	max. insertion depth E without limit stop mm	Suitable clamping nut	Tightening torque for clamping nut Nm	21505	...
40	GER 16	1 - 10	30	70	110	AER 16	55		101
40	GER 25	1 - 16	40	70	110	AER 25	55		105
40	GER 32	2 - 20	50	70	100	AER 32	55		109
40 L	GER 16	1 - 10	30	100	138	AER 16	85		102
40 L	GER 25	1 - 16	40	100	113	AER 25	85		106
40 L	GER 32	2 - 20	50	100	113	AER 32	85		110
40 XL	GER 16	1 - 10	30	160	200	AER 16	140		103
40 XL	GER 25	1 - 16	40	160	118	AER 25	140		107
40 XL	GER 32	2 - 20	50	160	135	AER 32	140		111

The new ATORN precision draw-in collet chuck

The chuck that is most precise is also the chuck that is most economical

Why use a particularly precise chuck, if it costs more than a standard draw-in collet chuck? This is easy to explain: Greater precision means better machining results, with better manufacturing tolerances and less rework. In addition, a longer service life of the cutting tools is achieved and the machine spindles are subjected to less wear. Overall, these advantages will save you far more than the manageable additional costs of a precision draw-in collet chuck. At any rate, with the ATORN precision draw-in collet chuck this is no longer an issue. Try it out.

Maximum true running accuracy

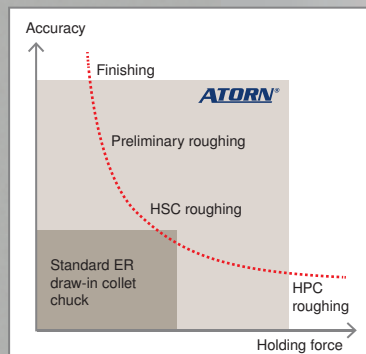

= Accuracy

Through unique, patented design features, the ATORN precision draw-in collet chuck offers significantly higher accuracy than is offered by a conventional ER draw-in collet chuck.

Principle-based force development

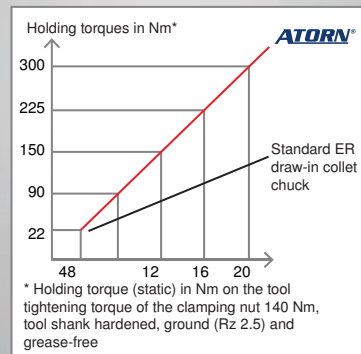

= Incredible stability

Through the design of the ATORN precision draw-in collet chuck the clamping forces are distributed uniformly over the entire cylindrical lateral surface area of the tool shank. Radial forces are optimally accommodated - perfect surfaces are produced when milling.



21507 - 21508 Precision collet Centro|P



- Type**
- Outer and inner taper ground
 - Concentricity and repeat precision 0.003 mm (with GER-HP collets)
 - Supply without clamping nut

Use
For high-precision clamping of tools with straight shank, without concentricity and clamping force loss, up to shank tolerance h10.

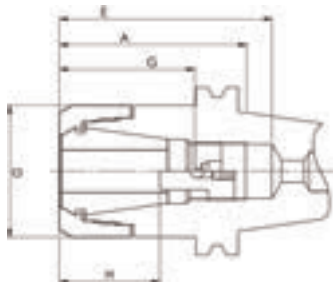

21507
Type
Standard design.

Taper ST	Size	Clamping range mm	Collets type	D mm	A mm	Insertion depth E mm	short	
							21507	...
40	CP 16	1 - 10	ER 16/426 E	30	70	110		103
40	CP 25	2 - 16	ER 25/430 E	40	70	110		108
40	CP 32	2 - 20	ER 32/470 E	50	70	111		113
50	CP 32	2 - 20	ER 32/470 E	50	70	120		116

Taper ST	Size	Clamping range mm	Collets type	D mm	A mm	Insertion depth E mm	medium length	
							21507	...
40	CP 16	1 - 10	ER 16/426 E	30	100	140		104
40	CP 25	2 - 16	ER 25/430 E	40	100	113		109
40	CP 32	2 - 20	ER 32/470 E	50	100	94		114
50	CP 32	2 - 20	ER 32/470 E	50	100	150		117

Taper ST	Size	Clamping range mm	Collets type	D mm	A mm	Insertion depth E mm	long	
							21507	...
40	CP 16	1 - 10	ER 16/426 E	30	160	200		105
40	CP 25	2 - 16	ER 25/430 E	40	160	118		110
40	CP 32	2 - 20	ER 32/470 E	50	160	135		115
50	CP 32	2 - 20	ER 32/470 E	50	160	200		118

21508 101-102
Type
Slim design.

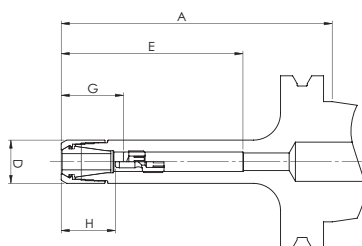

Taper ST	Size	Clamping range mm	Collets type	D mm	A mm	Insertion depth E mm	21508	
						
40	CP 11 M	1 - 7	ER 11/4008 E	16	100	68		101
40	CP 11 M	1 - 7	ER 11/4008 E	16	160	68		102

21508 201-202
Type
Tapered design.

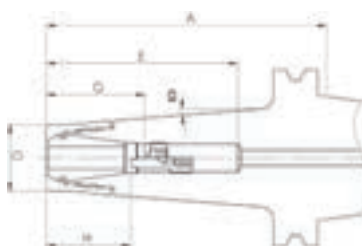

Taper ST	Size	Clamping range mm	Collets type	D mm	A mm	Insertion depth E mm	21508	
						
40	CPC 16C	1 - 10	ER 16/426 E	24	100	140		201
40	CPC 16C	1 - 10	ER 16/426 E	24	160	200		202

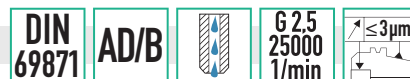

Note:
Collets with square drive are not suitable for taps.
Clamping nuts and wrench see cat.-no. 21509.
Sealing disc see cat.-no. 21513.
GER-HP/-HPD/-HPDD collets see cat.-no. 21546 - 21551 und 21563 - 21569.
Draw-in bolts see cat.-no. 21733 - 21740.



Clamping Technology



21543

OZ collet chucks

DIN 69871

AD/B



G 6.3
15000
1/min



Type

- Outer and inner taper ground
- Cap nut mounted in ball bearing

Scope of supply:

Incl. of clamping nut.

Use

For the clamping of tools with straight shank in collets DIN 6388.

Note:

ST 30 is delivered in the AD type.
Collets see cat.-no. 21552 - 21554.
Draw-in bolts see cat.-no. 21733 - 21740.



21543

Taper ST	Clamping range mm	for collets type	A mm	D mm	21543	...
30	2-16	415 E	60	43		101
40	2-25	462 E	70	60		103
40	3-32	467 E	90	72		104
50	2-25	462 E	70	60		105
50	3-32	467 E	80	72		106

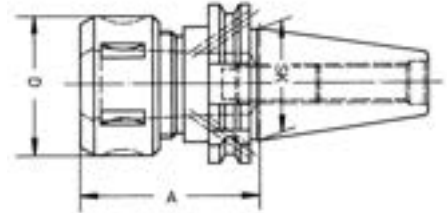

21577

Power chucks

DIN 69871

AD/B



G 6.3
12000
1/min



Type

- Clamping nut with needle roller cage
- Robust design, simple pre-setting and application
- High concentricity precision, torque transmission and stability
- Can be used with 3-32 mm reduction

Scope of supply:

Incl. of clamping nut.

Use

For clamping tools with straight shank. Also suitable for clamping Weldon shanks. Particularly suited for roughing.

Note:

Reduction sleeves see cat.-no. 21582.
Clamping wrench see cat.-no. 50650.
Draw-in bolts see cat.-no. 21733 - 21740.



21577

Taper ST	d mm	D mm	A mm	L mm	21577	...
40	20	48	60	41		101
40	32	66	95	82		102
50	20	48	80	61		103
50	32	66	75	56		104

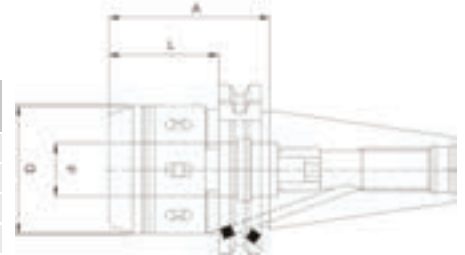

21580

Hydro expansion chucks

DIN 69871



G 2.5
25000
1/min



Type

- High concentricity precision and maximum torque transmission
- Vibration-damping tool clamping
- Easy to operate
- High positioning and repeat precision
- Made in Germany

Scope of supply:

Incl. Hexagon cross-grip wrench.

Use

For rough milling, drilling and reaming.
All standard shanks can be clamped.

Note:

Reduction sleeves see cat.-no. 21581.
Draw-in bolts see cat.-no. 21733 - 21740.
Wrench for coolant tube see cat.-no. 21865.

21580 100

Type
- Ultra-short

Taper ST	d ₁ mm	d ₂ mm	d ₃ mm	l ₁ mm	l ₂ mm	l ₃ mm	G	waf mm	21580	...
40	20	34	48	24.5	51	10	M 16 x 1	8		100 NEW

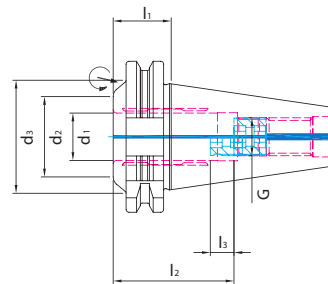

AD



21580 100

AD/B

21580 101-102

Type
- Short, heavy

Taper ST	d ₁ mm	d ₂ mm	l ₁ mm	l ₂ mm	l ₃ mm	G	waf mm	21580	...
40	20	49.5	64.5	51	10	M 16 x 1	8		101
50	32	72.0	81.0	61	10	M 16 x 1	8		102

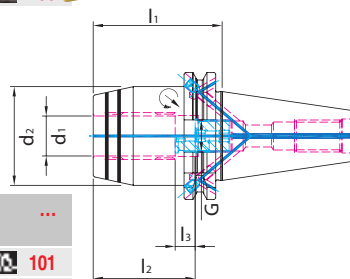

21580 101-102



21576 HHD roughing chuck



Type
 - Further development of the standard expansion chuck
 - Best torque transmission
 - High damping properties
 - High temperature resistance
Advantage:
 - All standard shanks can be clamped

Use
 For heavy-duty machining in respect of HSC, HPC and TF milling.

Note:
 Reduction sleeves see cat.-no. 21581.
 Draw-in bolts see cat.-no. 21733 - 21740.

NEW



21576

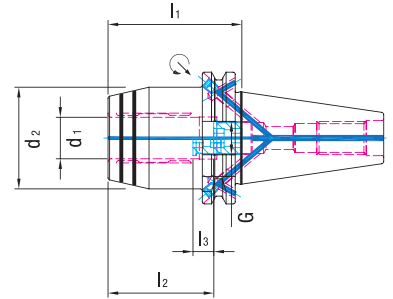

Taper	d ₁	d ₂	l ₁	l ₂	l ₃	G	waf	21576	...
ST	mm	mm	mm	mm	mm		mm		
40	12	42	50.0	46	10	M 8 x 1	3		101
40	20	49	64.5	51	10	M 16 x 1	8		102
50	20	49	64.5	51	10	M 16 x 1	8		103

21579 Hydro expansion extension



Type
 - Made of high-quality tempered tool steel

Use
 For extension and adaptation in various clamping tools.

NEW



21579

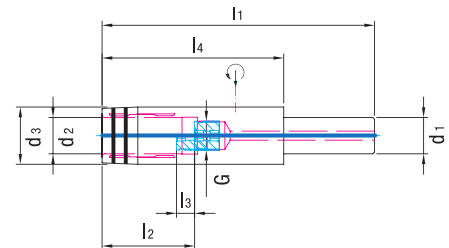

d ₁	d ₂	d ₃	l ₁	l ₂	l ₃	l ₄	G	21579	...
mm	mm	mm	mm	mm	mm	mm			
20	12	25.0	150	46	10	100	M 10 x 1		101
20	20	31.5	150	51	10	100	M 16 x 1		102
32	20	31.5	150	51	10	90	M 16 x 1		103
32	20	31.5	200	51	10	90	M 16 x 1		104

**Intelligent shrink technology
 Patented widening element**

- Distinctive
- Easy
- Extremely effective

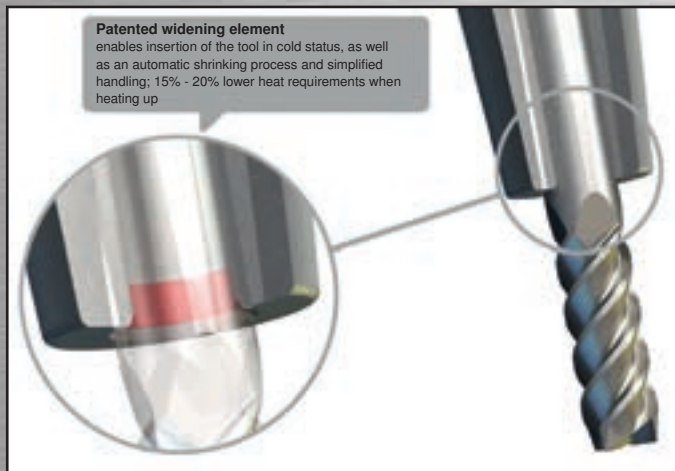

The patented widening element is used for automatic pre-centring of the tool and this means more precision for the shrink process without irritating tilting during the joining process. The shrink process can be executed automatically and without assistance.



Clamping Technology

diebold**Type**

- **Maximum concentricity precision** and taper tolerance
- Manufactured in an air-conditioned production facility

Advantages:

- High holding force and long service life through use of **high-quality hot-working steels** and specific heat treatment processes
- **Patented pre-width** facilitates automatic shrink process and simplified handling

Use

Suitable for clamping carbide, HSS, and steel shanks with a tolerance of h6.

Note:

Extension pieces see cat.-no. 21598.
Draw-in bolt see cat.-no. 21733 - 21740.
Shrink-fit positions see cat.-no. 21588 - 21595.

21596 701-722**Type**

- Slim, coated in stainless material

Taper ST	d1 mm	d2 mm	d3 mm	l1 mm	l2 mm	A mm	V mm	g	21596	...
40	3	15	20	20	32	80	5	M 6		498
40	4	15	20	20	32	80	5	M 6		499
40	5	15	20	25	32	80	5	M 6		500
40	6	20	27	36	45	80	10	M 5		501
40	8	20	27	36	45	80	10	M 6		502
40	10	24	32	42	50	80	10	M 8 x 1		503
40	12	24	32	47	50	80	10	M 8 x 1		504
40	14	27	34	47	50	80	10	M 10 x 1		505
40	16	27	34	50	50	80	10	M 12 x 1		506
40	18	33	42	50	57	80	10	M 12 x 1		507
40	20	33	42	52	57	80	10	M 16 x 1		508
40	25	44	50	58	60	100	10	M 16 x 1		509
40	32	44	50	62	38	100	10	M 16 x 1		510
40 L	6	21	27	36	45	120	10	M 5		550
40 L	8	21	27	36	45	120	10	M 6		551
40 L	10	24	32	42	50	120	10	M 8		552
40 L	12	24	32	47	50	120	10	M 8		553
40 L	14	27	34	47	50	120	10	M 8		554
40 L	16	27	34	50	50	120	10	M 12		555
40 L	18	33	42	50	57	120	10	M 12		556
40 L	20	33	42	52	57	120	10	M 16		557
40 XL	6	20	27	36	45	160	10	M 5		601
40 XL	8	20	27	36	45	160	10	M 6		602
40 XL	10	24	32	42	50	160	10	M 8 x 1		603
40 XL	12	24	32	47	50	160	10	M 8 x 1		604
40 XL	14	27	34	47	50	160	10	M 8 x 1		605
40 XL	16	27	34	50	50	160	10	M 12 x 1		606
40 XL	18	33	42	50	57	160	10	M 12 x 1		607
40 XL	20	33	42	52	57	160	10	M 16 x 1		608

Taper ST	d1 mm	d2 mm	d3 mm	l1 mm	NL mm	A mm	V mm	g	21596	...
40	3	9	13	20	60	83	5	M 6		701
40	4	10	14	20	60	83	5	M 6		702
40	6	12	18	36	60	83	5	M 5		703
40	8	14	20	36	60	83	5	M 6		704
40	10	16	22	42	60	83	5	M 8 x 1		705
40	12	18	24	47	60	83	5	M 10 x 1		706
40	16	22	28	50	60	83	5	M 12 x 1		707
40	20	27	33	52	60	83	5	M 16 x 1		708
40 L	3	9	16	20	100	123	5	M 6		709
40 L	4	10	17	20	100	123	5	M 6		710
40 L	6	12	22	36	100	123	5	M 5		711
40 L	8	14	24	36	100	123	5	M 6		712
40 L	10	16	26	42	100	123	5	M 8 x 1		713
40 L	12	18	28	47	100	123	5	M 10 x 1		714
40 L	16	22	32	50	100	123	5	M 12 x 1		715
40 L	20	27	37	52	100	123	5	M 16 x 1		716
40 XL	6	12	26	36	140	163	5	M 5		717
40 XL	8	14	28	36	140	163	5	M 6		718
40 XL	10	16	30	42	140	163	5	M 8 x 1		719
40 XL	12	18	32	47	140	163	5	M 10 x 1		720
40 XL	16	22	36	50	140	163	5	M 12 x 1		721
40 XL	20	27	41	52	140	163	5	M 16 x 1		722

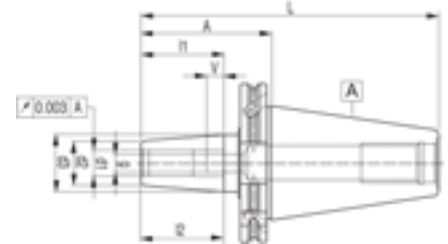
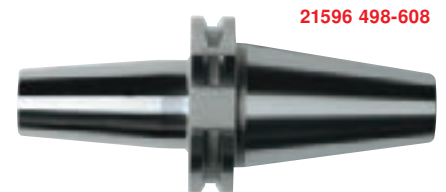
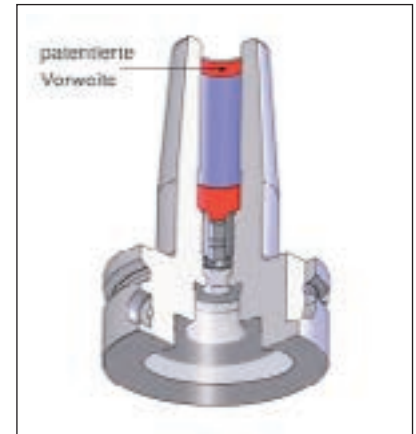

21614 - 21615 Shrinking chucks



- Type**
- Slim design
 - Made of specialist temperature-resistant hot-working steel
 - With additional threads around circumference
 - For subsequent balancing
 - With Balluf chip bore
 - Made in Germany

Scope of supply:
- With installed detent screw

Use
For shrink-fitting HSS and HM tools with a shank tolerance of h6 and better.

DIN 69871

AD/B



G 2.5
25000
1/min



NEW

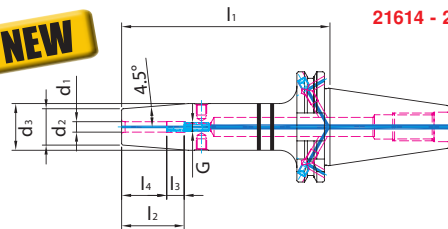

21614 - 21615

- 21614**
- Without coolant duct bores (KKB)
- 21615**
- With resealable cooling duct bores (KKB)

short		without KKB							with KKB			
Taper ST	d ₁ mm	l ₁ mm	d ₂ mm	d ₃ mm	l ₂ mm	l ₃ mm	l ₄ mm	G	21614	...	21615	...
40	3	80	10	17	28	16	12	M 6			101	101
40	4	80	15	22	28	12	16	M 6			102	102
40	5	80	15	22	30	10	20	M 6			103	103
40	6	80	21	27	36	10	26	M 5			104	104
40	8	80	21	27	36	10	26	M 6			105	105
40	10	80	24	32	41	10	31	M 8 x 1			106	106
40	12	80	24	32	47	10	37	M 10 x 1			107	107
40	14	80	27	34	47	10	37	M 10 x 1			108	108
40	16	80	27	34	50	10	40	M 12 x 1			109	109
40	18	80	33	42	50	10	40	M 12 x 1			110	110
40	20	80	33	42	52	10	42	M 16 x 1			111	111
40	25	100	44	53	58	10	48	M 16 x 1			112	112

medium length		without KKB							with KKB			
Taper ST	d ₁ mm	l ₁ mm	d ₂ mm	d ₃ mm	l ₂ mm	l ₃ mm	l ₄ mm	G	21614	...	21615	...
40	3	120	10	17	-	-	12	-			201	201
40	4	120	15	22	-	-	16	-			202	202
40	5	120	15	22	-	-	20	-			203	203
40	6	120	21	27	36	10	26	M 5			204	204
40	8	120	21	27	36	10	26	M 6			205	205
40	10	120	24	32	41	10	31	M 8 x 1			206	206
40	12	120	24	32	47	10	37	M 10 x 1			207	207
40	14	120	27	34	47	10	37	M 10 x 1			208	208
40	16	120	27	34	50	10	40	M 12 x 1			209	209
40	18	120	33	42	50	10	40	M 12 x 1			210	210
40	20	120	33	42	52	10	42	M 16 x 1			211	211

long		without KKB								
Taper ST	d ₁ mm	l ₁ mm	d ₂ mm	d ₃ mm	l ₂ mm	l ₃ mm	l ₄ mm	G	21614	...
40	3	160	10	17	-	-	12	-		301
40	4	160	15	22	-	-	16	-		302
40	5	160	15	22	-	-	20	-		303
40	6	160	21	27	36	10	26	M 5		304
40	8	160	21	27	36	10	26	M 6		305
40	10	160	24	32	41	10	31	M 8 x 1		306
40	12	160	24	32	47	10	37	M 10 x 1		307
40	14	160	27	34	47	10	37	M 10 x 1		308
40	16	160	27	34	50	10	40	M 12 x 1		309
40	18	160	33	42	50	10	40	M 12 x 1		310
40	20	160	33	42	52	10	42	M 16 x 1		311

extra long		without KKB								
Taper ST	d ₁ mm	l ₁ mm	d ₂ mm	d ₃ mm	l ₂ mm	l ₃ mm	l ₄ mm	G	21614	...
40	3	200	10	17	28	16	12	M 6		401
40	4	200	15	22	28	12	16	M 6		402
40	5	200	15	22	30	10	20	M 6		403
40	6	200	21	27	36	10	26	M 5		404
40	8	200	21	27	36	10	26	M 6		405
40	10	200	24	32	41	10	31	M 8 x 1		406
40	12	200	24	32	47	10	37	M 10 x 1		407
40	14	200	27	34	47	10	37	M 10 x 1		408
40	16	200	27	34	50	10	40	M 12 x 1		409
40	18	200	33	42	50	10	40	M 12 x 1		410
40	20	200	33	42	52	10	42	M 16 x 1		411



21614 101-112



21614 201-211



21614 301-311



21614 401-411

Clamping Technology



17676

Tool supports for screw-in millers



Type

- Precision type
- Outer taper and interference fit ground

Use

For mounting screw-in milling cutters with thread.

Note:

Draw-in bolts see cat.-no. 21733 - 21740.

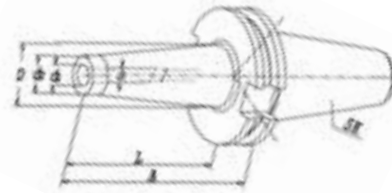

17676

d ₃ mm	ST	d ₁ mm	d ₂ mm	D mm	L mm	A mm	17676	...
M 6	40	6.5	10	13	25	44		101
M 6	40	6.5	10	20	50	69		102
M 6	40	6.5	10	23	75	94		103
M 8	40	8.5	13	15	25	44		104
M 8	40	8.5	13	23	50	69		105
M 8	40	8.5	13	23	75	94		106
M 8	40	8.5	13	25	100	119		107
M 10	40	10.5	18	20	25	44		108
M 10	40	10.5	18	23	50	69		109

d ₃ mm	ST	d ₁ mm	d ₂ mm	D mm	L mm	A mm	17676	...
M 10	40	10.5	18	28	75	94		110
M 10	40	10.5	18	32	100	119		111
M 12	40	12.5	21	24	25	44		112
M 12	40	12.5	21	31	75	94		113
M 12	40	12.5	21	36	125	144		114
M 16	40	17.0	29	29	25	44		115
M 16	40	17.0	29	34	75	94		116
M 16	40	17.0	29	40	125	144		117

21601

Tool adapters for drill chucks

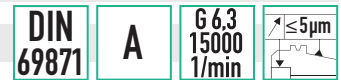

Type

- Precision type

Use

For mounting drill chucks in milling machines.

Note:

Draw-in bolts see cat.-no. 21733 - 21740.

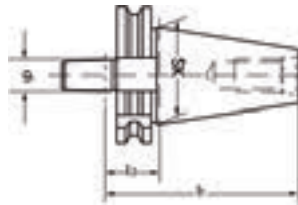

21601

Taper ST	mount d ₁ DIN 238	l ₂ mm	l ₁ mm	21601	...
40	B 16	25	93.4		301
50	B 16	25	126.75		303

21609

Taper sleeves



Type

- Precision type

Use

For mounting tools with MT shank and drive tang.

Note:

Draw-in bolts see cat.-no. 21733 - 21740.

21609 204-210



Type

- Precision-balanced G 2.5 - 25,000 rpm
- Coated in stainless material
- With Balluf chip bore

21609 301-319



Type

- Balanced G 6.3 - 15,000 rpm

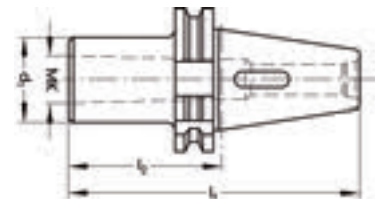

21609 207



21609 305



21609 306

Outer Taper SK	Inner Taper MK	l ₂ mm	l ₁ mm	d ₁ mm	ATORN® 21609	...	H+W 21609	...
30	1	50	97.8	25				301
30	2	65	112.8	32				302
30	3	80	127.8	40				303
40	1	50	118.4	25		204		304
40	2	50	118.4	32		205		305
40	2L	117	184.5	32		206		306
40	3	70	138.4	40		207		307
40	3L	133	201.4	40		208		308
40	4	95	163.4	48		209		309
40	4L	156	224.4	48		210		310
50	1	45	146.75	25				311
50	2	60	161.75	32				312
50	2L	117	218.75	32				313
50	3	65	116.75	40				314
50	3L	137	238.75	40				315
50	4	95	196.75	48				316
50	4L	167	268.75	48				317
50	5	105	206.75	63				318
50	5L	197	298.75	63				319

21613

Milling sleeves

DIN 69871

A

G 6.3
15000
1/min



Type

- Precision type with installed draw-in screw

Use

For mounting tools with MT shank and draw-in thread.

Note:

Draw-in bolts see cat.-no. 21733 - 21740.

External taper ST	Internal taper MT	Draw-in thread Internal	A mm	D mm	21613	...
40	1	M 6	50	25		101
40	2	M 10	50	32		102
40	3	M 12	70	40		103
40	4	M 16	95	48		104
50	2	M 10	60	32		106
50	3	M 12	65	40		107
50	4	M 16	70	48		108



21613



21618

Adapter sleeves

DIN 69871

A

G 6.3
15000
1/min



Type

- Precision type with installed draw-in screw

Use

For mounting and extending ST shanks.

Note:

Draw-in bolts see cat.-no. 21733 - 21740.

External taper ST	Internal taper ST	Draw-in thread external	Draw-in thread internal	l ₂ mm	l ₁ mm	d ₁ mm	21618	...
40	40	M 16	M 16	100	168.40	63		202
50	40	M 24	M 16	70	171.75	70		203
50	50	M 24	M 24	120	221.75	97		204



21618

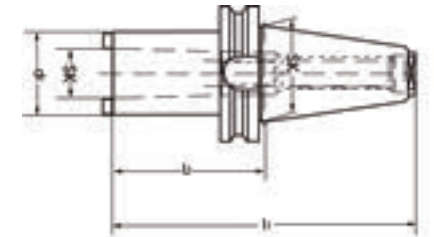

21625

HG collet chucks

DIN 69871

AD/B



G 2.5
25000
1/min



HSC

Haimer

Type

- High-precision and accurate collet
- Stable clamping
- High concentricity precision

Scope of supply:

With clamping screw and extraction hook.

Use

Very suitable for high-speed machining. For clamping tools with straight shank.

Note:

HG collets, see cat.-no. 21627.

Draw-in bolts see cat.-no. 21733 - 21740.

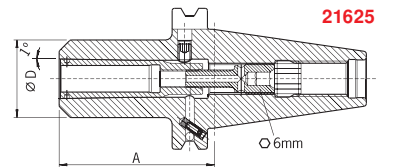

21625



short

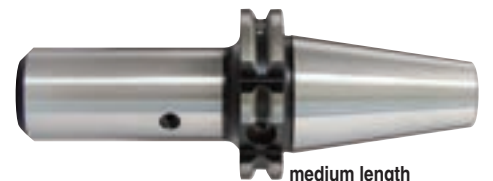

medium length

Taper ST	Size	A mm	Ø D mm	for HG collet Ø cat.-no. 21627	21625	...
40	1	65	30	3 / 4 / 5 / 6 / 8		101
50	1	65	30	3 / 4 / 5 / 6 / 8		104
40	2	70	35	10 / 12 / 14		107
50	2	70	35	10 / 12 / 14		110
40	3	75	48	16 / 18 / 20		113
50	3	75	48	16 / 18 / 20		116

Taper ST	Size	A mm	Ø D mm	for HG collet Ø cat.-no. 21627	21625	...
40	1	100	30	3 / 4 / 5 / 6 / 8		102
50	1	100	30	3 / 4 / 5 / 6 / 8		105
40	2	100	35	10 / 12 / 14		108
50	2	100	35	10 / 12 / 14		111
40	3	100	48	16 / 18 / 20		114
50	3	100	48	16 / 18 / 20		117

21627

HG Collets



Haimer

Type

- Spring steel hardened, ground and coated

Use

For HG chucks and shank tolerances h6.



21627

Clamping Ø mm	for size	21627	...
3	1		101
4	1		102
5	1		103
6	1		104

Clamping Ø mm	for size	21627	...
8	1		105
10	2		106
12	2		107
14	2		108

Clamping Ø mm	for size	21627	...
16	3		109
18	3		110
20	3		111



Type

- Precision type
- Bore tolerance < 0.004 mm

Use

For clamping tools with lateral Driving face in compliance with DIN 1835 B and DIN 6535 HB.

Note:

Draw-in bolts see cat.-no. 21733 - 21740.
Spare screw see cat.-no. 21635.

21631

ATORN®

Type

- Precision-balanced G 2.5 - 25,000 rpm
- Coated in stainless material
- With Balluf chip bore

21632

H+W

Type

- Balanced G 6.3 - 15,000 rpm

21631 109



21632 125



21632 126



21632 127

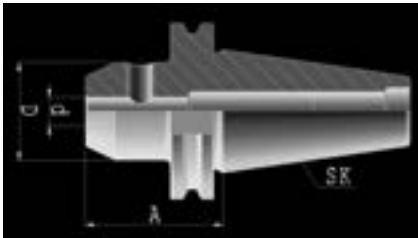

Taper ST	for miller shank Ø d mm	A mm	D mm	ATORN®		H+W	
				21631	...	21632	...
30	6	50	25				
30	8	50	28				101
30	10	50	35				102
30	12	50	42				103
30	16	63	48				104
30	20	70	52				106
40	6	50	25			209	109
40 L	6	100	25			210	110
40 XL	6	160	25			211	111
40	8	50	28			212	112
40 L	8	100	28			213	113
40 XL	8	160	28			219	114
40	10	50	35			220	115
40 L	10	100	35			221	116
40 XL	10	160	35			222	117
40	12	50	42			223	118
40 L	12	100	42			224	119
40 XL	12	160	42			225	120
40	14	50	44			226	121
40 L	14	100	44			227	122
40 XL	14	160	44			228	123
40 K	16	35	45			205	
40	16	63	48			229	125
40 L	16	100	48			230	126
40 XL	16	160	48			231	127
40	18	63	50			232	129
40 L	18	100	50			233	130
40 XL	18	160	50			234	131
40 K	20	35	45			206	
40	20	63	52			235	133
40 L	20	100	52			236	134
40 XL	20	160	52			237	135
40 K	25	35	50			207	
40	25	100	63			241	137

Taper ST	for miller shank Ø d mm	A mm	D mm	ATORN®		H+W	
				21631	...	21632	...
40 L	25	160	63				138
40 K	32	65	50			208	
40	32	100	72			243	140
40 L	32	160	72			244	
40	40	120	80			245	141
50	6	63	25				145
50 L	6	100	25				146
50 XL	6	160	25				147
50	8	63	28				148
50 L	8	100	28				149
50 XL	8	160	28				150
50	10	63	35				151
50 L	10	100	35				152
50 XL	10	160	35				153
50	12	63	42				154
50 L	12	100	42				155
50 XL	12	160	42				156
50	14	63	44				157
50 L	14	100	44				158
50 XL	14	160	44				159
50	16	63	48				160
50 L	16	100	48				161
50 XL	16	160	48				162
50	18	63	50				163
50 L	18	100	50				164
50 XL	18	160	50				165
50	20	63	52				166
50 L	20	100	52				167
50 XL	20	160	52				168
50	25	80	65				169
50 L	25	160	65				170
50	32	100	72				171
50 L	32	160	72				172
50	40	100	80				173

Miller supports | Tool holder for reversible cutting insert solid drilling tool

21620

Milling cutter mounts slim

DIN 69871

AD/B



G 2.5
25000
1/min



Type

- Extended, slim type
- Bore tolerance < 0.004 mm
- Shank hard surface-turned for quieter operation
- With ball joint clamping screw for **Weldon system and Whistle-Notch**
- With Balluf chip bore as standard

Scope of supply:

Through-hole stop screw.

Use

For clamping tools with lateral Driving face in compliance with DIN 1835 B and DIN 6535 HB.

Note:

Draw-in bolts see cat.-no. 21733 - 21740.

Spare screw see cat.-no. 21635.



21620

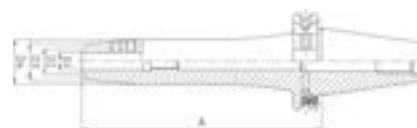

Taper ST	for miller shank-Ø D1 mm	A mm	D2 mm	D3 mm	D4 mm	medium length 21620	...
40	6	100	13	18	29	101	
40	8	100	15	20	31	103	
40	10	100	16	21	33	105	
40	12	100	17	22	35	107	
40	14	100	19	24	37	109	
40	16	100	21	26	39	111	
40	18	100	23	28	41	113	
40	20	100	25	30	43	115	

21621

Miller supports with KKB

DIN 69871

AD/B



G 2.5
25000
1/min



HPC

Type

- Shank hard surface-turned
- With Balluf chip bore
- With 2 coolant duct bores (KKB)
- With clamping screw and 2 x M3 screws for sealing the bore when required

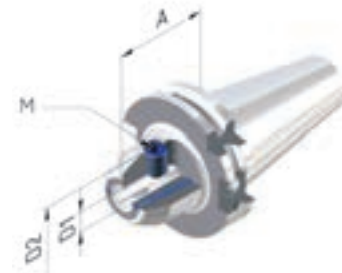

21621 101-110

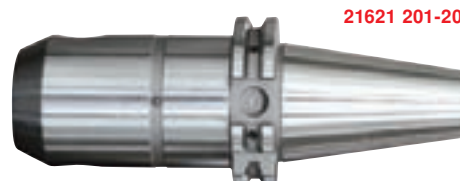

21621 201-207

Taper ST	D1 mm	A mm	D2 mm	L mm	M	short 21621	...
40	6	50	25	35	M 6	101	
40	8	50	28	35	M 8	102	
40	10	50	35	41	M 10	103	
40	12	50	42	48	M 12	104	
40	14	50	42	48	M 12	105	
40	16	63	48	51	M 14	106	
40	20	63	52	53	M 16	108	
40	25	100	65	60	M 18 x 2	109	
40	32	100	72	64	M 20 x 2	110	

Taper ST	D1 mm	A mm	D2 mm	L mm	M	medium length 21621	...
40	6	100	25	35	M 6	201	
40	8	100	28	35	M 8	202	
40	10	100	35	41	M 10	203	
40	12	100	42	48	M 12	204	
40	16	100	48	51	M 14	206	
40	20	100	52	53	M 16	207	



www.atorn.de

Performance requires quality.

For example, with the solid carbide high-performance ALUSPEED drill, from ATORN.

- 6x guiding section
- Solid carbide Ultra finest grit
- Al-CC-coating
- to 8xD
- Twisted cooling channel

ATORN®
Performance requires quality.



21637

Milling cutter mounts with coolant bore

DIN
69871

AD/B

G 6.3
15000
1/min**HHW****Type**

- Precision type.
- Bore tolerance <math>< 0.004 \text{ mm}</math>
- **With coolant bore**

Advantage:

Swarf is flushed away more effectively by the coolant pressure.

Use

For clamping tools with lateral Driving face in compliance with DIN 1835 B and DIN 6535 HB.

Note:

Draw-in bolts see cat.-no. 21733 - 21740.
Spare screw see cat.-no. 21635.

21637

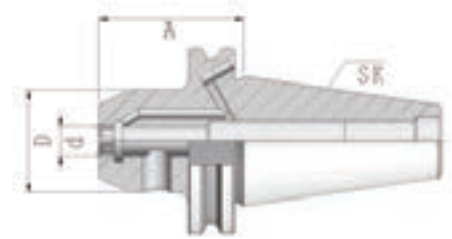

Taper ST	for milling cutter shank $\varnothing d$ mm	A mm	D mm	short	
				21637	...
40	6	50	25		201
40	8	50	28		204
40	10	50	35		207
40	12	50	42		210
40	14	50	44		213
40	16	63	48		216
40	18	63	50		219
40	20	63	52		222
50	6	63	25		301
50	8	63	28		302
50	10	63	35		303
50	12	63	42		304
50	14	63	44		305
50	16	63	48		306
50	18	63	50		307
50	20	63	52		308
50	25	80	65		309

Taper ST	for milling cutter shank $\varnothing d$ mm	A mm	D mm	medium length	
				21637	...
40	6	100	25		202
40	8	100	28		205
40	10	100	35		208
40	12	100	42		211
40	14	100	44		214
40	16	100	48		217
40	18	100	50		220
40	20	100	52		223
40	25	100	63		225
40	32	100	72		227
40	40	120	80		229
50	32	100	72		310
50	40	100	80		311

21639

Tool holder for reversible cutting insert solid drilling tool

DIN
69871

AD/B

G 6.3
15000
1/min**HHW****Type**

- Precision type.
- High concentricity precision with flat-ground supporting surface (precision <math>< 0.003 \text{ mm}</math>)

Advantages:

With the offset threaded dowel the supporting surface of the drill is pulled towards the enlarged unit diameter, providing better tool support and facilitating higher feed rates.

Use

For all solid drilling tools with straight shank DIN 6595 part 1.

Note:

Draw-in bolts see cat.-no. 21733 - 21740.
Spare screw see cat.-no. 21635.

21639

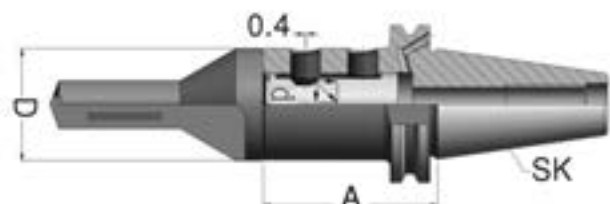
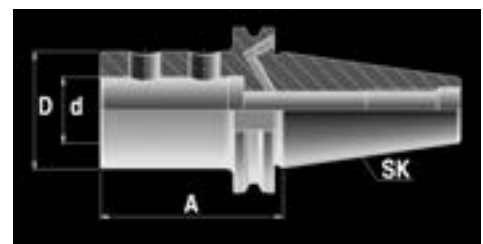

Taper ST	d mm	A mm	D mm	21639	...
40	20	65	40		101
40	25	70	45		102
40	32	75	52		103
50	20	70	40		104
50	25	70	45		105
50	32	70	52		106

21650

Combination milling cutter arbors

DIN 69871

AD



G 2.5
25000
1/min

G 6.3
15000
1/min



Type

- Precision type.
- Flat-ground supporting surface (precision < 0.003 mm)

Scope of supply:

Incl. of feather key, driving ring and draw-in screw.

Use

With feather key for milling cutters with longitudinal keyway e.g. DIN 841 and driving ring for milling cutters with transverse slot DIN 1880 and milling heads DIN 1830.

21650 601-614

ATORN®

Type

- Precision-balanced 2.5 - 25,000 rpm
- Coated in stainless material
- With Balluf chip bore

21650 102-520

H/W

Type

- Balanced 6.3 - 15,000 rpm

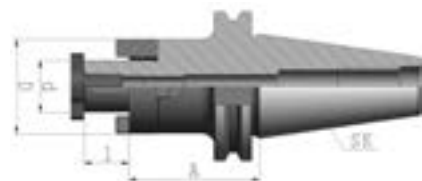

Note:

Draw-in bolts see cat.-no. 21733 - 21740.

Driver rings see cat.-no. 21655.

Draw-in screws, see cat.-no. 21656 and 21659.

Draw-in screw wrench, see cat.-no. 21657.

short					ATORN®		H/W	
Taper	d	A	D	l	21650	...	21650	...
ST	mm	mm	mm	mm				
30	16	50	32	17				102
30	22	50	40	19				103
30	27	55	48	21				104
40	16	55	32	17			601	202
40	22	55	40	19			604	204
40	27	55	48	21			607	206
40	32	60	58	24			610	208
40	40	60	70	27			613	210
50	16	55	32	17				501
50	22	55	40	19				503
50	27	55	48	21				505
50	32	55	58	24				507
50	40	55	70	27				509



21650 604



21650 204



21650 205



medium length					ATORN®		H/W	
Taper	d	A	D	l	21650	...	21650	...
ST	mm	mm	mm	mm				
40	16	100	32	17			602	203
40	22	100	40	19			605	205
40	27	100	48	21			608	207
40	32	100	58	24			611	209
40	40	100	70	27			614	211
50	16	100	32	17				502
50	22	100	40	19				504
50	27	100	48	21				506
50	32	100	58	24				508
50	40	100	70	27				510

21650 215



long					ATORN®		H/W	
Taper	d	A	D	l	21650	...	21650	...
ST	mm	mm	mm	mm				
40	16	160	32	17			603	213
40	22	160	40	19			606	215
40	27	160	48	21			609	217
40	32	160	58	24			612	219
40	40	160	70	27				221
50	16	160	32	17				512
50	22	160	40	19				514
50	27	160	48	21				516
50	32	160	58	24				518
50	40	160	70	27				520

Clamping Technology



21671

Milling head mounts

DIN 69871

AD



G 2.5
25000
1/min

G 6.3
15000
1/min



Type

- Precision type with enlarged and surface-ground supporting surface
- Brief unload for greater stability

Use

For Shell End Milling Cutters and Milling Cutters with Transverse Keyway.

Note:

$d = 40$ and 60 mm additionally with 4 threaded holes for direct mounting.

Draw-in bolts see cat.-no. 21733 - 21740.

Draw-in bolts see cat.-no. 21656 and 21659.

Draw-in bolt wrench, see cat.-no. 21657.

21671 101-114

ATORN[®]

Type

- Precision-balanced G 2.5 - 25,000 rpm
- Coated in stainless material
- With Balluf chip bore

21671 304-410

H/W

Type

- Balanced G 6.3 - 15,000 rpm



21671 104



21671 306



21671 310



Taper ST	d mm	A mm	D mm	l mm	ATORN [®]		H/W	
					21671	...	21671	...
40	16	35	38	17	101	...	304	...
40	22	35	48	19	104	...	305	...
40	27	40	58	21	107	...	306	...
40	32	50	78	24	110	...	307	...
40	40	50	88	27	113	...	308	...
50	22	35	48	19	402	...
50	27	40	58	21	403	...
50	32	50	78	24	404	...
50	40	50	88	27	405	...
50	60	70	128	40	406	...

Taper ST	d mm	A mm	D mm	l mm	ATORN [®]		H/W	
					21671	...	21671	...
40	22	100	48	19	105	...	309	...
40	27	100	58	21	108	...	310	...
40	32	100	78	24	111	...	311	...
40	40	100	88	27	114	...	312	...
50	22	100	48	19	407	...
50	27	100	58	21	408	...
50	32	100	78	24	409	...
50	40	100	88	27	410	...

21675

Blade head supports with KKB

DIN 69871

AD/B



G 2.5
25000
1/min



HPC

Type

- Taper shank, locating journal and supporting surface ground on collar
- Shank hard surface-turned
- With Balluf chip bore
- With 2 coolant duct bores (KKB)

Scope of supply:

With miller draw-in screw.



21675

Taper ST	D1 mm	A mm	D2 mm	L1 mm	M	21675	...
40	16	35	38	17	M 8	101	...
40	22	35	48	19	M 10	102	...
40	27	35	60	21	M 12	103	...
40	32	50	78	24	M 16	104	...



21683

Boring bar blanks

DIN 69871

Type

- Steep taper and collar hardened and ground
- Material 16 MnCr5

Use

For manufacturing special tools.

Taper ST	Boring bar $\varnothing d_1$ mm	l_2 mm	21683	...
40	63.0	250	102	...
50	97.0	315	201	...



21683

